



2017



RAM
COMMERCIAL

RAM PROMASTER CITY

WE RULE THIS TOWN.

RIGHTFULLY AIMING FOR HEAD OF THE CLASS. With a design that promotes low costs of overall ownership and an impressive list of best-in-class features, the 2017 Ram ProMaster City® easily earns top-tier consideration.

What you get in Ram ProMaster City is a commercial vehicle that provides an elegant and economical solution which puts comfort, durability, efficiency and performance at the top of the game.



So consider it all. The 2.4L Tigershark® MultiAir®2 I-4 engine delivers **best-in-class¹* horsepower and torque** and is mated to a **class-exclusive¹ 9-speed automatic transmission**, which helps enable **best-in-class¹ highway fuel economy—28 mpg highway[†]**.

Capability is key. Here, Ram ProMaster City ranks on top, with **best-in-class¹ payload, best-in-class¹ cargo capacity and best-in-class¹ cargo width between the wheel wells.**

Towing is equally as competent; when properly equipped, this commercial-grade worker delivers exceptional trailering capability. Count on an **unsurpassed¹ towing rating that invites trailers up to 2,000 lb.[‡]**

Created for the specific needs of city and suburban conditions, these vehicles give cost-conscious businesses or a large family all the right stuff: performance, functionality and, best of all, an emphasis on low costs of operation. You can get more at ramtrucks.com/promastercity

Below: The 2017 Ram ProMaster City Passenger Wagon SLT with available roof rack side rails and aluminum wheels.
Next page: ProMaster City Tradesman® Cargo Van.

*A note about this catalog: all disclaimers and disclosures can be found on page 24. [†]EPA estimated 21 mpg city/28 mpg hwy. Actual results may vary. [‡]When properly equipped.



— AMERICA'S —
MOST EFFICIENT
— WORK VAN² —



CS
CONNECTION
SYSTEMS

CYBER SOLUTIONS

Fort



BEST-IN-CLASS¹ HWY FUEL ECONOMY

28 MPG HWY^{*}

2.4L TIGERSHARK[®] MULTIAIR² I-4



A FOCUS ON LOW COSTS OF OWNERSHIP PAYS OFF BIG. Ram ProMaster City[®] was designed to provide impressive performance along with supremely low costs of ownership and operation. We accomplished both—and you reap all the benefits.

The gas-sipping 2.4L Tigershark 4-cylinder with MultiAir² technology is partnered with a **class-exclusive¹ asset—the super-efficient 9-speed automatic transmission**; a combination that enables **best-in-class¹ hwy fuel economy**, with 0-30 mph takeoff in only 3.7 seconds. Driving range is just as impressive—up to 448 miles[†] on a tank of 87-octane regular. To help save both costs and time, oil change intervals can reach up to 10,000 miles. Now factor in the outstanding protection of a 5-Year/60,000-Mile Powertrain Limited Warranty,³ and you've got it all. Short and sweet, Ram ProMaster City delivers superb value.

5YR/60,000MI³
POWERTRAIN LIMITED WARRANTY

*EPA estimated 21 mpg city/28 mpg hwy. Actual results may vary. [†]EPA estimated 21 mpg city/28 mpg hwy and 16-gallon fuel tank. Actual results may vary.

BEST-IN-CLASS¹ 131.7 CUBIC FEET OF CARGO CAPACITY.



Properly secure all cargo.



IT'S GOT THE MUSCLE TO DO BIG JOBS. AND THE BRAINS TO DO THEM RIGHT. EVERY TIME.

It carries credentials and cargo with ease. The 2.4L Tigershark[®] 4-cylinder engine with MultiAir[®]2 technology teams up with the class-exclusive¹ 9-speed automatic for exceptional power and spirited 0–30 mph times—while giving Ram ProMaster City[®] stellar fuel-efficient performance. Both the Tradesman[®] and Tradesman SLT Cargo Van trim levels offer a vast rear area with cargo floor length greater than 7 feet. Loading pallets? Huge 48-inch-wide rear door openings let you access the **best-in-class¹ 48.4-inch cargo width between the wheel wells**—just-right dimensions to accommodate a standard pallet.

Extra-spacious room for large items—like appliances for the kitchen or laundry room—is designed-in, with 51.8 inches from floor to interior roof. Add convenient passenger-side and rear overhead lamps in the cargo compartment and six D-type tie-down rings (integrated in the floor, with up to 1,000-lb capacity when in use). It all culminates in pure Ram leadership: **best-in-class¹ cargo capacity of 131.7 cubic feet and best-in-class¹ payload up to 1,883 pounds.** From deliveries to custom upfits, this Cargo Van is ideally suited for specific tailoring, thanks to the many authentic accessories available from Mopar[®].

ROOF WEIGHT CAPACITY

150 LB*

*When properly equipped.

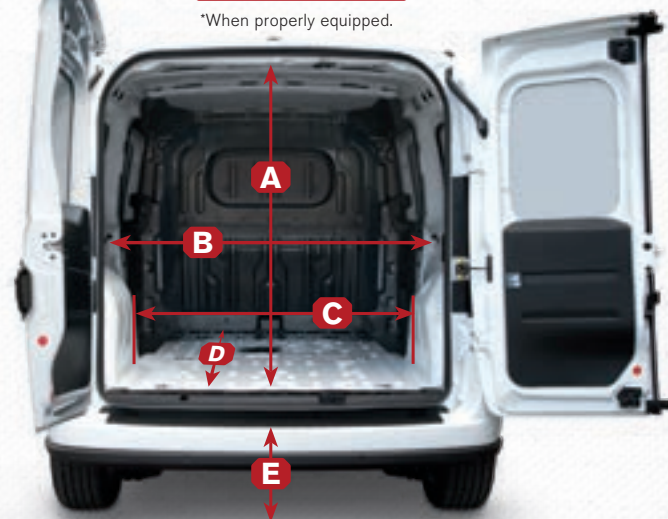

A	CARGO AREA HEIGHT	51.8"
B	CARGO AREA WIDTH	60.4"
C	CARGO WIDTH BETWEEN WHEEL WELLS¹	48.4"
D	CARGO AREA LENGTH	87.2"
E	REAR LIFT-IN HEIGHT	23.3"





BEST-IN-CLASS

48.4 INCHES

CARGO WIDTH BETWEEN THE WHEEL WELLS



BEST-IN-CLASS

1,883 LB

MAXIMUM PAYLOAD

**YOU NEED A MOBILE WORKSHOP.
WE CAN ROLL WITH THAT.**





▶ OPEN TO CABIN

Standard on Tradesman® Cargo Van and SLT Cargo Van



▶ PARTITION

Available for Tradesman Cargo Van and SLT Cargo Van



▶ PARTITION WITH WINDOW

Available for Tradesman Cargo Van and SLT Cargo Van

PARTITIONS FOR CONTROL, PRIVACY AND SECURITY.

Choose from three treatments for your Ram ProMaster City® Cargo Van interior.

Standard is an open and roomy space that allows immediate access from the front-seat area to the rear. If a closed-off rear space is preferable, choose the solid partition; should you need to monitor your cargo, opt for the partition with fixed window. Both of these available Cargo Partition Packages include rear wall trim.



INSIDE AND OUT, IT'S READY-MADE FOR YOUR UPFIT.

It totally measures up: **best-in-class¹ cargo capacity of 131.7 cubic feet.** Seven feet of flat cargo floor length. Huge 60/40 split rear doors. Nearly vertical side walls. But let's get real: the total volume of a side-by-side fridge/freezer comes in around 32 cu ft; a typical washer and dryer combined, around 48 cu ft. Compare those figures to this cavernous 131.7 cu ft of workable volume, and start thinking about an interior upfit that still leaves room for supplies and equipment, or a mobile workshop with enough space remaining to accommodate additional storage for tools and other materials.

NEED EXTRA CAPABILITY? HIT THE ROOF. Every Ram ProMaster City model is built for maximum capability. Six pre-drilled receivers in the roof structure can house roof rails rated up to 150 lb of carrying capacity.

And since we shared the specs with a wide variety of manufacturers, you can choose from the authentic accessories from Mopar® or other sources. The winning strategy to this game is adaptability and versatility. Your Ram ProMaster City delivers it all.



FROM PAINT TO PALLET, THIS VAN CAN HANDLE IT ALL.

Competitively offering 51.8 inches from floor to ceiling, Cargo Van also gives you **best-in-class¹ cargo width between the wheel wells.** As shown above, even with custom shelving installed in the rear, there's still enough room in the center cargo area for additional equipment. While each of these five-gallon paint cans weighs about 50 lb, these five are a mere fraction of the **best-in-class¹ payload—up to 1,883 lb**—exactly why this Cargo Van can easily transport a standard loaded pallet.



**PERFECT FOR ANY
BUSINESS PLAN.**

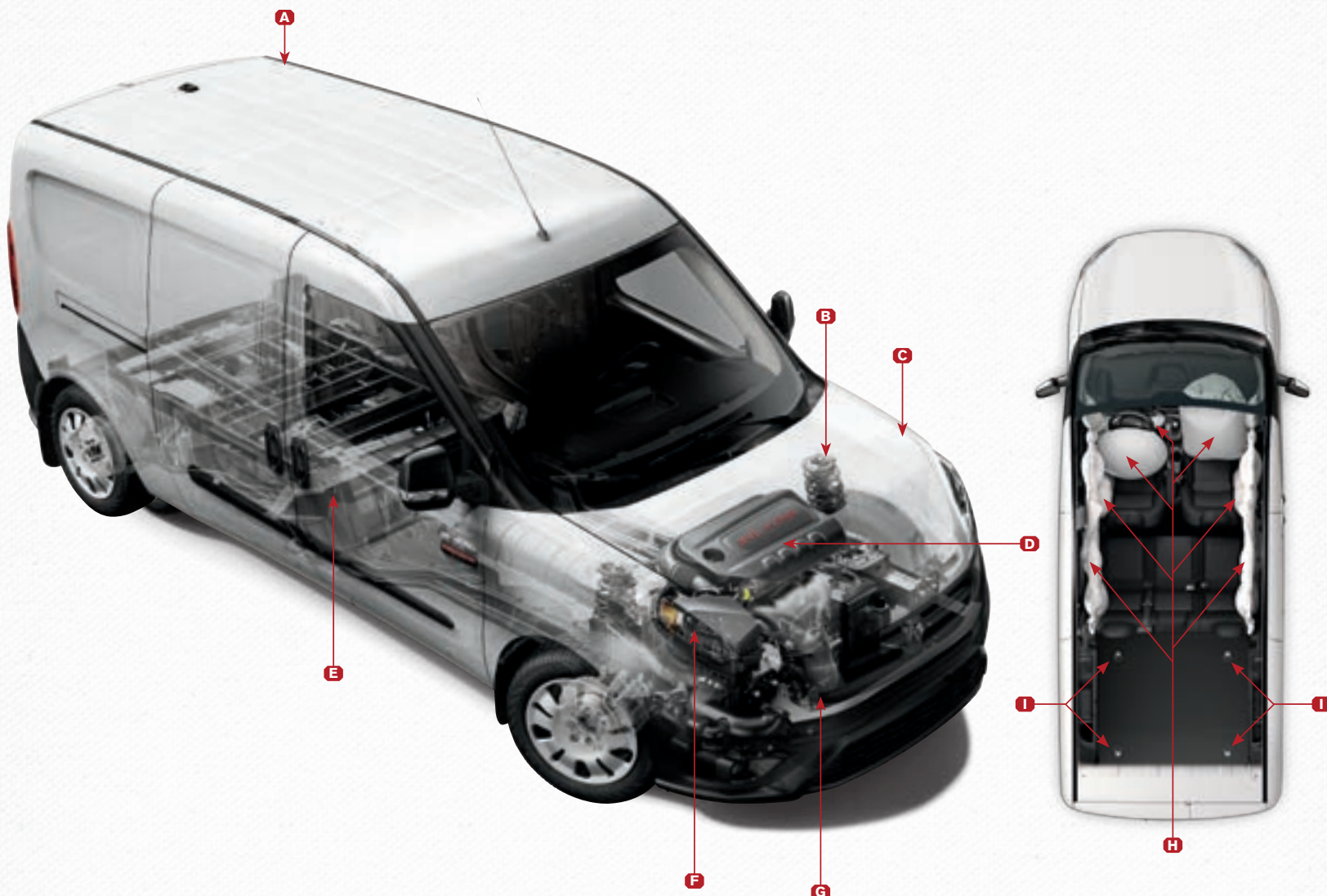

A TOP-LEVEL CARGO MANAGEMENT. In-roof pre-drilled receptacles are already in place for numerous aftermarket accessories, including available Roof Rails from Mopar®. Molded in color with a Silver finish, they carry a 150-lb rating and will accommodate a variety of available assets, including Roof Top Cargo Carriers, Bike Carriers, Ski Carriers and Watersports Carriers. Search mopar.com for a complete inventory.

B TWIN-TUBE MACPHERSON STRUTS are large-diameter (52 mm), easily supporting this best-in-class* GVWR. We also added GVWR-tuned high-performance stamped-steel clamshell-sectioned control arms with a steel crossmember, specifically tuned springs, a solid 26-mm-diameter stabilizer bar with cast-iron knuckles and large-sized coil springs.

C SLEEK AERODYNAMIC DESIGN. Thoroughly wind-tunnel tested, Ram ProMaster City® delivers a minimal coefficient of drag (CD) of only 0.30. While this enables an impressively quiet interior, reducing wind resistance acts as a major contributor to the impressive fuel efficiency.



D 2.4L TIGERSHARK® MULTI-AIR® 2 I-4 WITH THE CLASS-EXCLUSIVE! 9-SPEED AUTOMATIC TRANSMISSION.

As the only gas-powered 4-cylinder engine in the Ram portfolio, the 2.4L Tigershark takes full advantage of the MultiAir2 valve train system. Internal components include a high-pressure die-cast aluminum block, and a forged steel crankshaft with powder-metal forged steel connecting rods and cast-aluminum pistons. Individual oil squirters help keep internal temperatures in the ideal range, and the position of the exhaust manifold helps reduce noise in the engine compartment. Pulse-width modulation technology on the alternator and fuel pump helps contribute to operating efficiency; acceleration is impressive: it's a mere 3.7 seconds from a full stop to 30 mph.

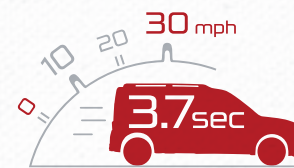

E A SOLID BACKBONE was a major mandate for this body-frame integral (unibody) design. This chassis employs a stout, integrated frame structure, strategically boxed frame components, multiple crossrails and robust and comfortable suspension technology. The engineering enables top-level capability on Cargo Van—**best-in-class! payload and unsurpassed! towing!** The **best-in-class! GVWR of 5,395 lb** infers outstanding capability, with GCWR rated at a solid and substantial 5,900 lb.

F THE HEADLAMP SYSTEM is high-mounted above common crash zones to help mitigate damage (and costs) in the event of a collision. The system includes the Follow Me Home function, illuminating the front of the vehicle via the headlamps for a preset time.

G RACK AND PINION STEERING WITH FRONT-WHEEL DRIVE shows its advantage in the tight turning radius, a flat-floor cargo area and the easy step-in height. This hydraulic-assist system with premium steering gear is engineered and tuned to meet the rigorous demands of the commercial market; curb-to-curb turns are only 42 feet. The adjustable tilt/telescoping steering column is standard.

H SEVEN STANDARD AIR BAGS!* Few competitive vehicles in the class offer so many. These include dual-stage driver and front-passenger air bags, side air bag inflatable curtains, front seat-mounted thorax air bags, class-exclusive! driver's-side knee air bag, along with dual front seat belt pretensioners and seat belt load limiters.

I IN-FLOOR TIE-DOWN RINGS help secure cargo, and are standard on every Ram ProMaster City model (6 rings on Cargo Van; 4 rings on Wagon models).

J PARKVIEW® REAR BACK-UP CAMERA® is an available accessory that displays the rear scene in the optional 5-inch radio touchscreen. Automatically in operation when in Reverse, on-screen grid lines help when backing up to docks and trailers, or into parking spaces.

K THE PARKSENSE® REAR PARK ASSIST SYSTEM® is packaged with the available ParkView Rear Back-Up Camera. It's activated when in Reverse, and operates below 8 mph. To alert the driver, audible warnings increase in intensity as the vehicle nears obstructions to the rear.



*When properly equipped.

SAFETY AND SECURITY: WE'VE GOT YOU COVERED.

YOU'RE CARRYING CARGO, PASSENGERS, OR BOTH. THIS IS HOW YOU PROTECT ALL OF IT. Every 2017 Ram ProMaster City® model features one of the most comprehensive and advanced technologies for handling, maneuvering and road manners: the Electronic Stability Control (ESC)⁶ System. This system integrates the antilock braking system (ABS) with a variety of All-Speed Traction Control technologies that address all four corners of the vehicle in response to lateral movement and the steering input from the driver. ESC⁶ assists in maintaining control under conditions such as wet or snow-covered roads and during tight turns and evasive maneuvers to counter the unexpected. Calibrated to engine output, ESC⁶ includes four-channel ABS, Brake/Lock Differential, a full-function All-Speed Traction Control System, Brake Assist, Engine Drag Control, Trailer Sway Control⁹, Hill Start Assist and Electronic Roll Mitigation.

THE CLASS-EXCLUSIVE¹ 9-SPEED TRANSMISSION



Featuring Electronic Range Select (ERS), the 9-speed automatic is a major factor in achieving outstanding fuel efficiency. Considered to be superior in gear range, ratio spread and gear transitions to many of its 6-speed counterparts, it dispenses with conventional large-diameter friction discs in favor of dog clutches. With gear disengagement and actuation similar to a manual transmission, it uses shorter mid-range gears with near-frictionless operation. Factor in the higher 7th, 8th and 9th transitions, and you've got multiple reasons for the exceptional and fuel-efficient performance of every Ram ProMaster City model.

THE CLASS-EXCLUSIVE¹ BI-LINK REAR SUSPENSION



Another unique feature—and one specifically designed for Ram ProMaster City—is the bi-link rear suspension. This category-unique configuration delivers comfort for passengers, enables confident hauling and offers enhanced stability. Our engineers employed a steel crossmember with an optimum weight/stiffness ratio to help improve reaction to lateral loads; the technology also contributes to improved handling. The steel, cargo-rated coil springs supply high-fatigue endurance and work with tough telescopic twin-tube hydraulic shocks designed for minimal mass and maximum performance. A 16-mm solid stabilizer bar with optimized torsional stiffness also ensures long-lasting durability.

EXPECT PREMIUM LEVELS OF COMFORT AND ELECTRONICS.



THE CREATIVITY OF THE INTERIOR DESIGN TEAM focused on developing a versatile, large and people-friendly interior. Ram ProMaster City® Cargo Van and Passenger Wagon models deliver a welcoming vast space loaded with state-of-the-art electronics and communications technology.

All interiors utilize durable and easy-to-clean surfaces with user-friendly interfaces. Seating in both models is exemplary; these bucket seats with long-lasting fabrics are designed for maximum comfort.

Personal space and storage are plentiful, with ample room for shoulders, hips and long legs in the front seats of all models. Rear seating in Passenger Wagon comfortably accommodates up to three passengers—and still provides significant cargo room behind the rear seats. Entry and exit through the two oversized side sliding doors on Wagon are easy and unhindered.

The team's quest for quiet resulted in a vehicle-length acoustic headliner and a plush floor carpet that stretches from cab to rear cargo area in Wagon. No matter which ProMaster City you're driving, this interior gives you total convenience and functionality.

Uconnect®

OUR SMARTEST CALL WAS TO STUDY THE SMARTPHONE.

A smartphone goes far beyond calling, and your radio should do the same. Start with a true-to-fidelity 3.0 AM/FM radio with four speakers. Now add the Uconnect® 5.0 system—optional on Tradesman®, standard on SLT, with Bluetooth® and Integrated Voice Command⁷ with a five-inch color touchscreen. Available Uconnect 5.0 with Navigation adds GPS Navigation and Points of Interest. Available SiriusXM® Satellite Radio[®] includes a one-year trial subscription. Stay in touch, and stay in the know, with the world of Uconnect—audio and technology at their best.



RADIO 3.0

- ▶ AM/FM stereo
- ▶ MP3 capability with auxiliary input
- ▶ Media hub with USB and auxiliary inputs
- ▶ Three-inch screen
- ▶ Four-speaker sound system



UCONNECT 5.0

- ▶ AM/FM stereo
- ▶ MP3 capability with auxiliary input
- ▶ Media hub with USB and auxiliary inputs
- ▶ Bluetooth with Integrated Voice Command⁷
- ▶ Steering wheel-mounted audio controls
- ▶ Five-inch color touchscreen
- ▶ Four-speaker sound system



UCONNECT 5.0 with NAV

- ▶ All features of the Uconnect 5.0 system
- ▶ GPS Navigation
- ▶ Points-of-Interest (POI) accessibility
- ▶ Turn-by-turn navigation

PASSENGER WAGON: READY FOR BUSINESS. AND FAMILIES.



WHEN IT COMES TO MOVING PEOPLE, YOU'VE COME TO THE RIGHT PLACE. Meet Ram ProMaster City® Passenger Wagon: a working exercise that puts a premium on smart flexibility. From seating configurations to generous front storage to abundant and accessible rear cargo capacity, this robust workhorse fulfills the need with room to spare. From the business of daily shuttle to the semiweekly Little League games, this Wagon delivers top-of-the-line assets and conveniences.

Far from taking a back seat, the innovative design of the second row in ProMaster City Wagon reflects pure practicality and standout versatility. The rear seat is engineered for exceptional occupant comfort, with ample room for three passengers. Also key is a **fold-and-tumble rear-seat design that enables nine different configurations**; you'll accommodate virtually any transport need. Dual side doors slide open, and rear doors—with their smart and safety-oriented 60/40 split design with the larger door on the driver's side—are the ideal design for curbside loading.

The maximum cargo area width (a huge 57.6 inches) joins long-wearing and useful carpeted floors and a full acoustic headliner; in short, it's supremely quiet. Front tubular bucket seats with spring suspensions and durable fabrics offer easy in-and-out access. Headrests are fully adjustable, seatbacks recline—and you can further opt for manual lumbar support controls for the driver's seat and heated surfaces for both front seats.



LARGE ENOUGH FOR THE WHOLE FAMILY. AND THEN SOME.

Ram ProMaster City Wagon redefines the family vehicle. Cargo capacity behind the second-row seats is 74.1 cu ft; fold the rear seats for a cavernous 101.7 cu ft. (An easy comparison is a standard washer/dryer combination; it's around 48 cu ft—less than half of this volume.) And while standard and available Safety and Security features abound, nothing beats your best buddy looking out for you and yours.

Properly secure all cargo. Animals should always be safely and properly secured while vehicle is in motion.



ABOVE ALL, WE WELCOME YOUR ALTERNATIVE TRANSPORTATION.

Our engineers left everything to the imagination and nothing to chance—which is why we raised the roof for greater possibilities in life. Rated up to 150 lb, the lightweight aluminum Roof Rails available from Mopar® (shown above) are just the ticket for handling bikes, extra luggage, sports equipment—and much more. Life with Ram ProMaster City® is all about practicality and capability; no surprise to find that these tough Roof Rails are designed to accommodate dozens of other useful authentic accessories by Mopar, to make transport and travel much easier.

CONFIGURE IT OUT FOR YOURSELF: IT FITS EVERY LIFESTYLE.

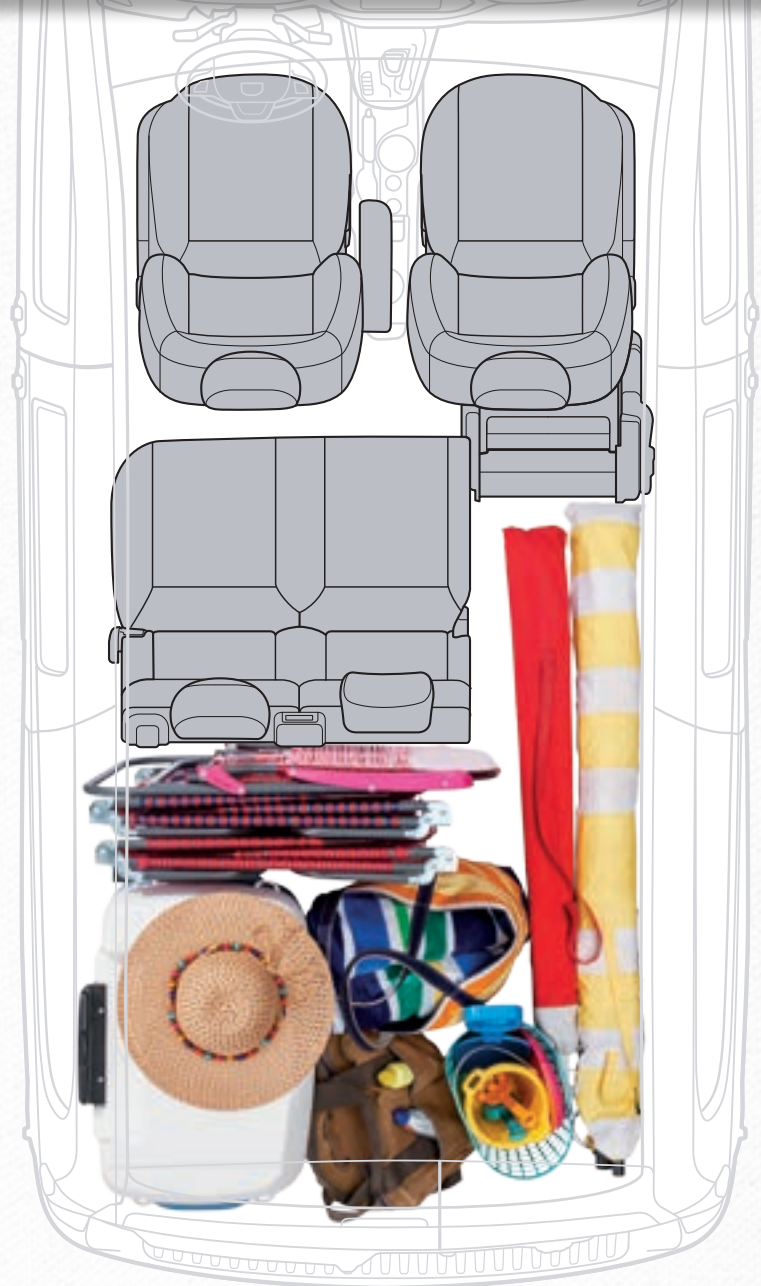
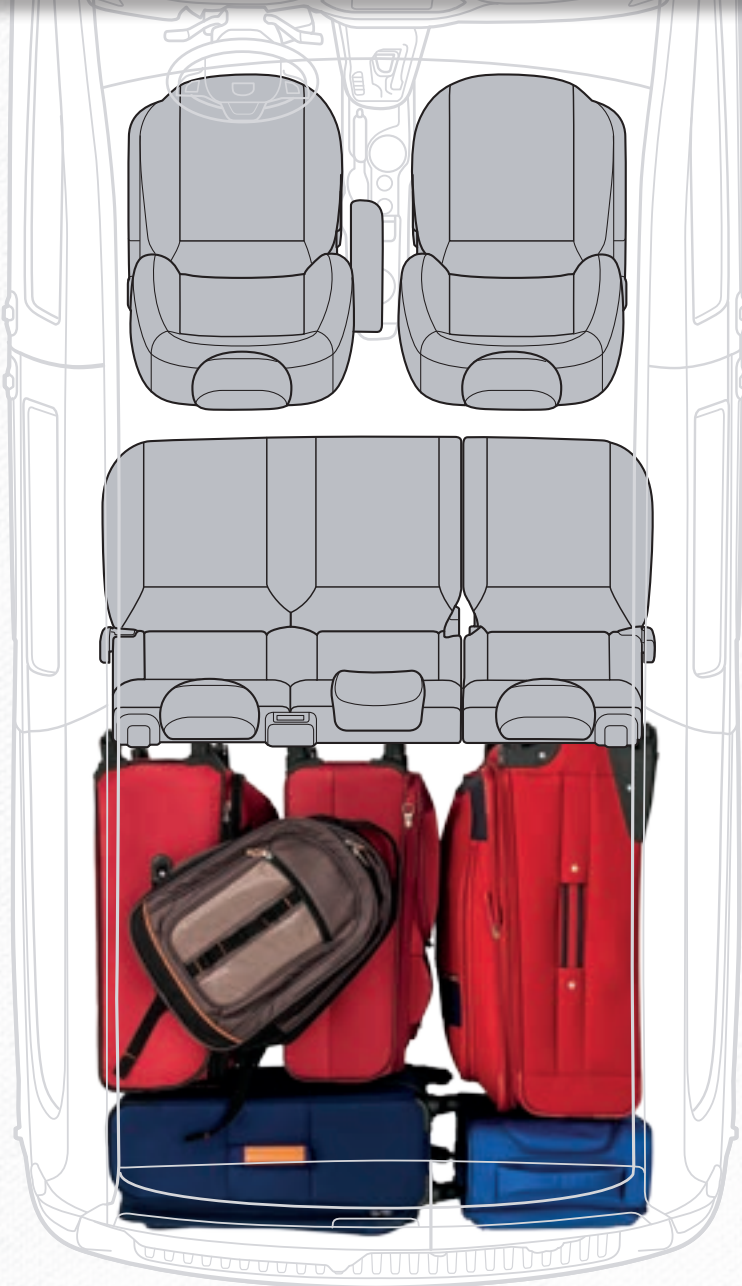

Convenient overhead storage



In-dash storage bin and oversized glove box



In-door storage bin with angled bottle carrier

Properly secure all cargo.

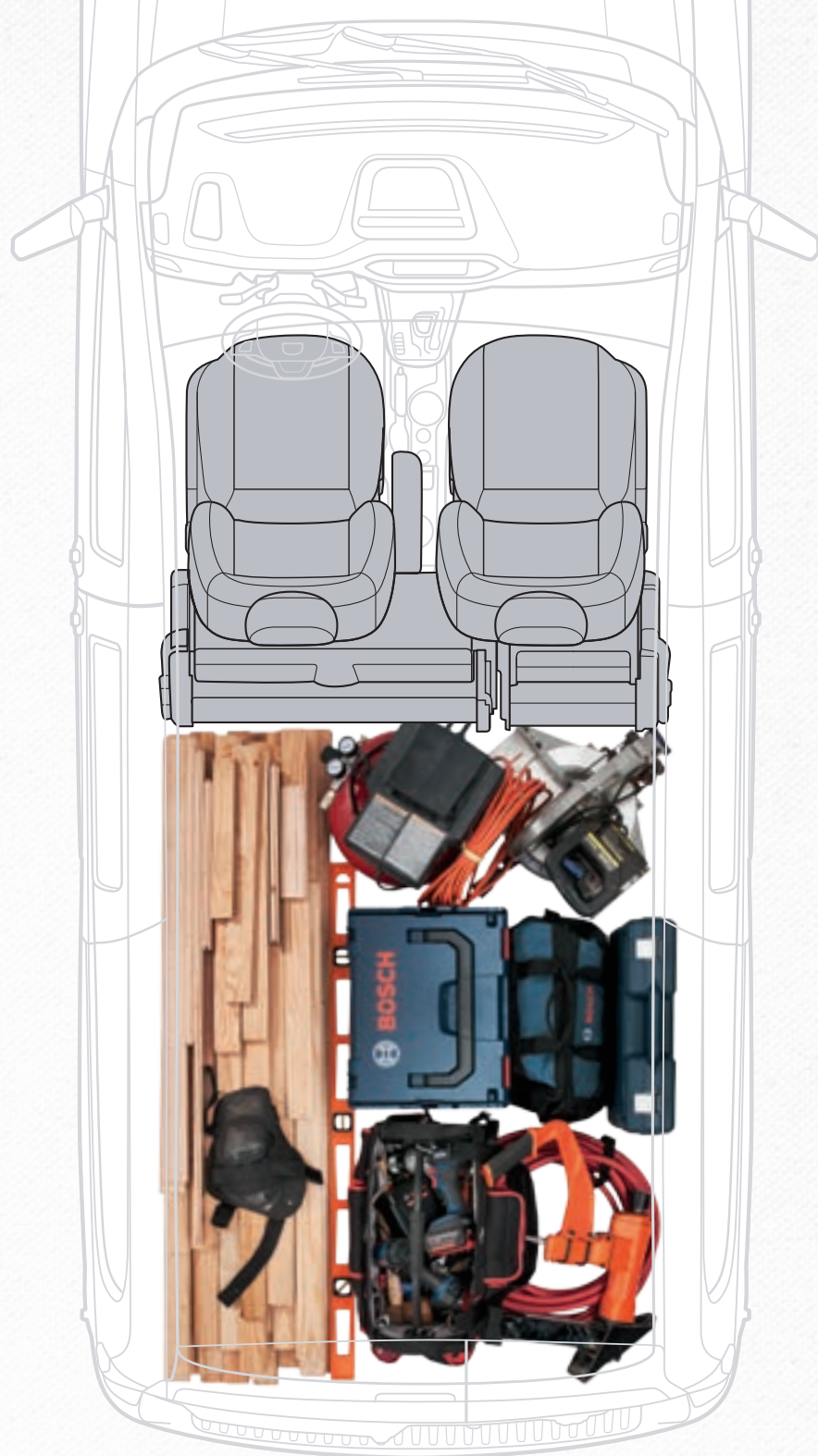
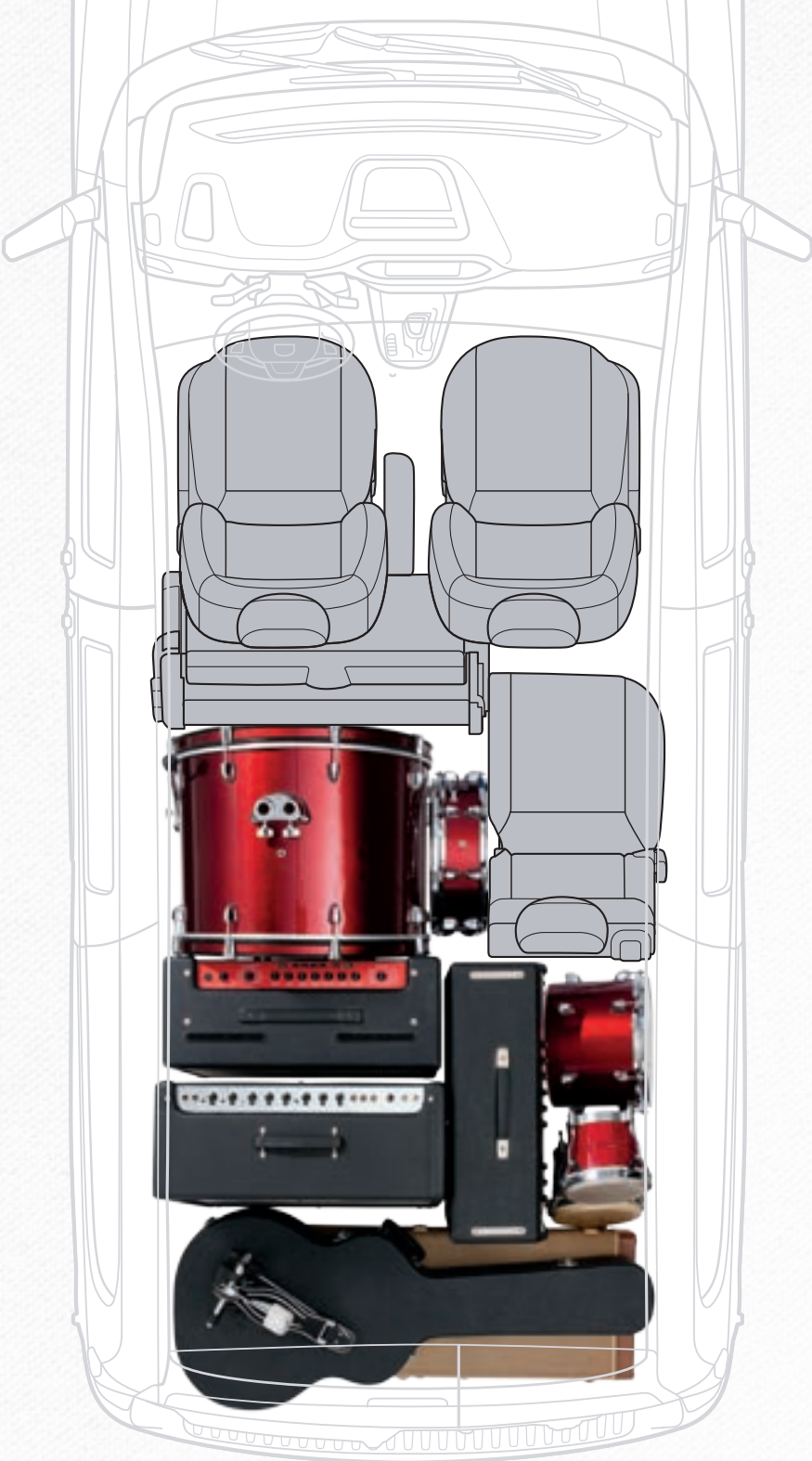

HOW TO BECOME THE LEADER OF THE PACKED. Start with a 60/40 split configuration, add fold-and-tumble rear-seat design for three, two, or a single occupant; the results are nine distinctive seating and cargo-carrying formations—exactly the versatility needed by shuttles, taxis, companies and families. So many possibilities invite you to think big.

Storage space is impressive—and abundant. A standard overhead front shelf system runs nearly the full length of the roof bow. Angled downward, it measures some five inches high and seven inches deep, accommodating everything from gloves to ice scrapers to notebooks.

The oversized glove box (176.9 cu in) accompanies a large, open, 12-inch-wide by 4-inch-deep in-dashboard storage bin; there's more storage

immediately in front of the driver, here designed as concave trays that are ideal for holding and stashing valuables and personal devices.

Multiple storage pockets and trays around the media center join a center console with two cup holders and two 12-volt capped auxiliary power outlets. USB and auxiliary connections are forward of the shifter, for at-hand access to power; recharging capability is smart and intuitive.

The illustrations above speak to the versatility of the Ram ProMaster City® design, showing just a few of the possible configurations achieved by this smartly engineered interior. No matter what your personal or business need, you'll find ample storage space along with adaptable and occupant-friendly cargo-carrying capacity at your service.



Properly secure all cargo.



THE IDEAL PARTNER WHEN YOU NEED A HAND.

RAM PROMASTER CITY®: WE'RE ALL ABOUT AUTOMOBILITY. Ram ProMaster City Cargo Van and Passenger Wagon were built with adaptability in mind. No wonder these versatile models are so ideally suited for a wide variety of mobility-minded upfits and personal customization that enable independent travel. The expansive side door openings provide huge, unimpeded access, and the 60/40 rear doors can easily accommodate a wheelchair with occupant. With in-floor D-rings on all models (four on Wagon and six on Cargo Van), you've got plenty of anchoring options for wheelchairs and accessories. The Passenger Wagon adds additional comfort measures—like optional power second-row windows and variable seating dynamics—topped off with the welcome quietness that comes from a carpeted cabin throughout the vehicle.



THIS IS THE SOLUTION THAT WORKS. Converting a Ram ProMaster City for wheelchair or disabled access is a designed-in advantage. Exemplifying this are two customized solutions. Far left, this convenient swing-out front seat uses third-party aftermarket electrohydraulic controls; near left is one of many examples of how the rear can be adapted. This upfit employs an aftermarket lift for wheelchairs or scooters, and the rear area is large enough to store it after use. It all comes together for all the right reasons: impressive GVWR, huge interior, generous door openings to the side and rear. Ram ProMaster City is built to meet virtually every transport need out there.

Automobility upfit is aftermarket only. Properly secure all cargo.

MAKE IT COMPLETELY YOUR OWN.



MOPAR® HAS CUSTOMIZATION IN MIND. When you design and build a commercial vehicle to deliver the quality and capability of a Ram ProMaster City®, you devote countless hours to ensure that it will perform over the long run. It's why our engineers worked with our colleagues at Mopar to incorporate dozens of practical ideas and designs to maximize performance, convenience and safety. Authentic accessories from Mopar open up a world of vehicle durability and versatility. Discover how Mopar accessories and service can help you and your Ram ProMaster City achieve new levels of productivity and utility. See your Ram ProMaster City dealer or click over to mopar.com



▶ LED Cargo Area Lights



▶ DOT-Approved Roadside Safety Kit



▶ Cargo Tote



▶ All-Weather Mats



▶ Cargo Area Security Cover



▶ Premium Carpet Cargo Mat



▶ Trailer Tow Wiring Harness*



▶ Hitch Receiver*



▶ Molded Splash Guards



▶ Removable Roof Rack – Three-Bar Utility (shown with PVC Carriers[†])

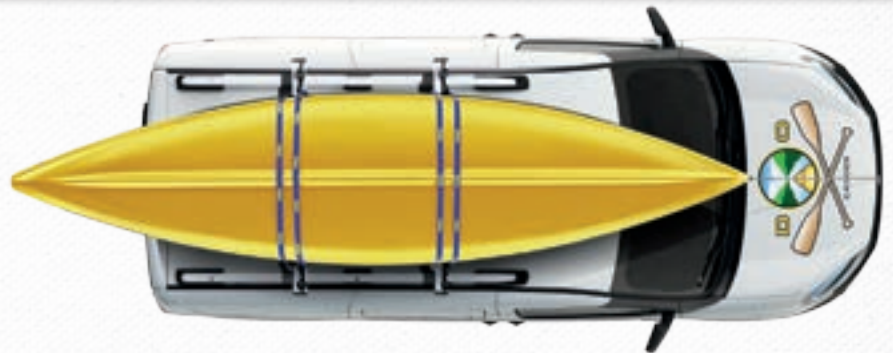

▶ Side Rails with Adjustable Crossbars and Roof-Mount Canoe Carrier[†]



▶ Side Rails with Adjustable Crossbars and Roof-Mount Ski and Snowboard Carrier[†]



▶ Side Rails with Adjustable Crossbars and Roof Box Cargo Carrier[†]

*Check User Guide for hitch type, load capacity and heavy-duty equipment required. Do not exceed rated tow capacity of the vehicle as equipped. Trailer may require items not supplied by Mopar. [†]Not available from Mopar; sold separately. [‡]Carrier mounts to the Side Rails with Adjustable Crossbars or Removable Roof Rack; accessories are sold separately.

TRADESMAN® CARGO VAN

Two-person seating

TRADESMAN SLT CARGO VAN

Two-person seating

WAGON

Five-person seating

WAGON SLT

Five-person seating



2017 RAM PROMASTER CITY® BUYER'S GUIDE

	Tradesman Cargo Van	Tradesman SLT Cargo Van	Wagon	Wagon SLT
CPOS PACKAGE	2TC	2TD	2TA	2TB
ENGINE AND TRANSMISSION				
2.4L TIGERSHARK® MULTIAIR® 2 I-4 WITH 9-SPEED AUTOMATIC	24C	24D	24A	24B
MECHANICAL FEATURES				
ALTERNATOR – 160-amp	•	•	•	•
BATTERY – 700-amp maintenance-free	•	•	•	•
BRAKES – 4-wheel antilock	•	•	•	•
ELECTRONIC VEHICLE TRACKING SYSTEM (EVTS)	0	0	0	0
FUEL TANK – 16-gallon	•	•	•	•
TIRE SERVICE KIT	•	•	•	•
EXTERIOR FEATURES				
BODYSIDE MOLDING – Black	•	•	•	•
BUMPERS – Front and rear Black	•	•	•	•
– Body-color		•		•
DAYTIME RUNNING LIGHTS	0	0	0	0
DOORS – Rear hinged doors with fixed glass and sliding side doors with vented glass for Wagon models			•	•
– Rear hinged doors with fixed glass and sliding side doors with vented glass for Cargo Vans	0	0		
– Rear hinged doors with fixed glass	0	0	•	•
– Side sliding right door with vented glass (passenger-side only; packaged with rear hinged doors with fixed glass and sliding side doors with vented glass)	0/P	0/P		
– Side sliding left door with vented glass (driver-side only; packaged with rear hinged doors with fixed glass and sliding side doors with vented glass)	0/P	0/P		
– Rear doors with 180-degree opening	•	•	•	•
– Side and rear doors with solid panels	•	•		
FOG LAMPS – Front (requires Lights and Wheels Group)		P		P
GLASS – Deep-tint (not available with side sliding rear doors with solid panels on Cargo Vans)	0	P	0	•
HEADLAMPS – Halogen	•	•	•	•
MIRRORS – Remote, manual-adjustable	•		•	
– Power-adjustable, folding, heated with body-color caps		•		•
ROOF RACK – Side Rails	0	0	0	0
– Roof Rack Crossbars (requires Roof Rack Side Rails)	0	0	0	0
CROSSBARS – 3-Bar Utility (cannot be installed with Roof Rack Side Rails)	0	0	0	0
SPLASH GUARDS – Set	0	0	0	0
TIRES – 215/55R16XL BSW All-Season	•	•	•	•
WHEELS – 16-inch steel painted Silver with center cap	•		•	
– 16-inch steel painted Black with full-painted Silver wheel covers	0	•	0	•
– 16-inch aluminum (requires Lights and Wheels Group)		P		P
INTERIOR FEATURES				
AIR CONDITIONING	•	•	•	•
CARGO AREA LIGHTING – LED	0	0		
DOOR LOCKS – Power, speed-sensitive	•	•	•	•
FLOOR MATS – Front and rear carpet			0	0
– Front and rear slush			0	0
– Front carpet	0	0		
– Front slush	0	0		

• = Standard 0 = Optional P = Part of Package

2017 RAM PROMASTER CITY[®] BUYER'S GUIDE (CONTINUED)

	Tradesman [®] Cargo Van	Tradesman SLT Cargo Van	Wagon	Wagon SLT
CPOS PACKAGE	2TC	2TD	2TA	2TB
INTERIOR FEATURES (CONTINUED)				
LIGHTING – Map/courtesy/cargo lamps	•	•	•	•
SEATS – 60/40 fold-and-tumble 3-person rear bench			•	•
– Cloth low-back bucket with manual adjuster	•		•	
– Heated front (included with the Popular Equipment Group)		P		P
– Premium cloth bucket with driver-side manual lumbar and height adjusters		•		•
SPEED CONTROL	0	•	0	•
STEERING COLUMN – Tilt/telescoping	•	•	•	•
STEERING WHEEL	•		•	
– Leather-wrapped (included with Uconnect [®] 5.0)	P	•	P	•
WINDOWS – Front, power with 1-touch up/down	•	•	•	•
– 2nd-row power (included with Popular Equipment Group)		P		P
MULTIMEDIA				
MOPAR [®] WEB WIFI HOTSPOT ⁹	0	0	0	0
RADIOS – 3.0 AM/FM includes Media Hub with USB and auxiliary input	•		•	
– Uconnect 5.0 AM/FM with 5-inch touchscreen display, Media Hub (with USB and auxiliary input), Integrated Voice Command ⁷ with Bluetooth [®] (includes leather-wrapped steering wheel with audio controls on Tradesman models)	0	•	0	•
– Uconnect 5.0 AM/FM/NAV with 5-inch touchscreen display, Media Hub (with USB and auxiliary input), GPS Navigation, Integrated Voice Command ⁷ with Bluetooth (includes leather-wrapped steering wheel with audio controls on Tradesman models)	0	0	0	0
SIRIUSXM [®] SATELLITE RADIO ⁸ (requires Uconnect 5.0 or Uconnect 5.0 NAV)	0	0	0	0
SPEAKERS – Four	•	•	•	•
– Six (packaged with Popular Equipment Group)				P
SAFETY AND SECURITY				
AIR BAGS ⁴ – Front driver and passenger	•	•	•	•
– Driver inflatable knee bolster	•	•	•	•
– Supplemental front-seat side	•	•	•	•
– Supplemental side-curtain for the 1st and 2nd rows			•	•
– Supplemental side-curtain for the 1st row	•	•		
BACK-UP CAMERA ⁵ WITH REARVIEW MIRROR/MONITOR (not available with ParkView [®] Rear Back-Up Camera ⁵)	0	0	0	0
DOT-APPROVED ROADSIDE SAFETY KIT	0	0	0	0
ELECTRONIC STABILITY CONTROL (ESC) ⁶ – Includes Brake-Lock Differential, Electronic Roll Mitigation, Hill Start Assist, Trailer Sway Damping ⁶ Brake Assist and All-Speed Traction Control	•	•	•	•
PARKSENSE [®] REAR PARK ASSIST ⁵ – Included with the Rear Back-Up Camera Group; not available with 3.0 radio	P	P	P	P
PARKVIEW REAR BACK-UP CAMERA ⁵ – Included with the Rear Back-Up Camera Group; not available with 3.0 radio	P	P	P	P
REMOTE KEYLESS ENTRY	•	•	•	•
REMOTE START SYSTEM (late availability)	0	0	0	0
TIRE PRESSURE MONITORING SYSTEM – Warning lamp	•	•	•	•
PACKAGES/EQUIPMENT GROUPS				
CARGO PARTITION PACKAGE – No window (includes rear wall trim)	0	0		
– With window (includes rear wall trim)	0	0		
LIGHTS AND WHEELS GROUP – Includes front fog lamps and 16-inch aluminum wheels		0		0
POPULAR EQUIPMENT GROUP – Includes heated front seats, 2nd-row power windows and 6 speakers (Wagon models); not available with sliding side and rear doors with solid panels on Cargo Van models		0		0
REAR BACK-UP CAMERA GROUP – Includes ParkView Rear Back-Up Camera ⁵ and ParkSense Rear Park Assist System ⁵ (not available with 3.0 radio)	0	0	0	0
REAR WIPER/WASHER/DEFROSTER GROUP – Includes rear window defroster and rear window wiper/washer (requires deep-tint sunscreen glass; not available with sliding side and rear doors with solid panels)	0	0	0	0
TRAILER TOW GROUP – Includes Class III hitch receiver with 4- and 7-pin wiring harness	0	0	0	0

• = Standard 0 = Optional P = Part of Package



2.4L TIGERSHARK® MULTIAIR² I-4

Mated to the **class-exclusive¹ 9-speed automatic transmission**, Ram ProMaster City[®] delivers **best-in-class¹ horsepower and torque**, along with unsurpassed¹ towing*—up to 2,000 lb on Cargo Van. Calibrated for wallet-friendly 87-octane gasoline, this in-line 4-cylinder powerplant also stands out with a **best-in-class¹ driving range with standard motor: up to 448 miles[†] per tank**. Given all the impressive figures and backed with a comprehensive 5-Year/60,000-Mile Powertrain Limited Warranty,³ these are tough commercial vehicles designed with low costs of operation in mind.

178 HORSEPOWER 174 LB-FT OF TORQUE

5 YR / 60,000 MI³
POWERTRAIN LIMITED WARRANTY

SPECIFICATIONS

2.4L TIGERSHARK MULTIAIR2 I-4

HORSEPOWER	178 hp @ 6,400 rpm
TORQUE	174 lb-ft @ 3,800 rpm
CONFIGURATION	In-line four-cylinder
DISPLACEMENT	144 cu in / 2360 cc
BORE x STROKE	3.46 x 3.82 in / 88.0 x 97.0 mm
BLOCK MATERIAL	Aluminum
CYLINDER HEAD MATERIAL	Aluminum
AIR INDUCTION	Naturally aspirated
VALVE TRAIN	Chain-driven DOHC, 16-valve
FUEL DELIVERY	Sequential, multiport injection
RECOMMENDED FUEL	Unleaded regular (87 octane)
COMPRESSION RATIO	10.0:1
ALTERNATOR	160-amp
OIL CAPACITY	5.5-qt



Properly secure all cargo.

*When properly equipped. [†]EPA estimated 21 mpg city / 28 mpg hwy and 16-gallon fuel tank. Actual results may vary.

SPECIFICATIONS

PAYLOAD/TOWING

(maximum capacities; in pounds)

	TRADESMAN® CARGO VAN	TRADESMAN SLT CARGO VAN	WAGON	WAGON SLT
GVWR	5,395	5,395	5,395	5,395
GCWR	5,900	5,900	5,900	5,900
CURB WEIGHT	3,512	3,512	3,682	3,682
MAXIMUM PAYLOAD*	1,883	1,883	1,713	1,713
MAXIMUM TOWING†	2,000	2,000	1,867	1,867

Trailer Weight Rating and Tow Vehicle Trailing Weight are calculated as specified in SAE J2807. Driver and passenger weight = 300 lb. Trailer Equipment Weight = 50.7 lb for conventional hitch.
*Maximum payload based on body model, GVWR class. †When properly equipped. Specifications subject to change. See dealer for most up-to-date information.

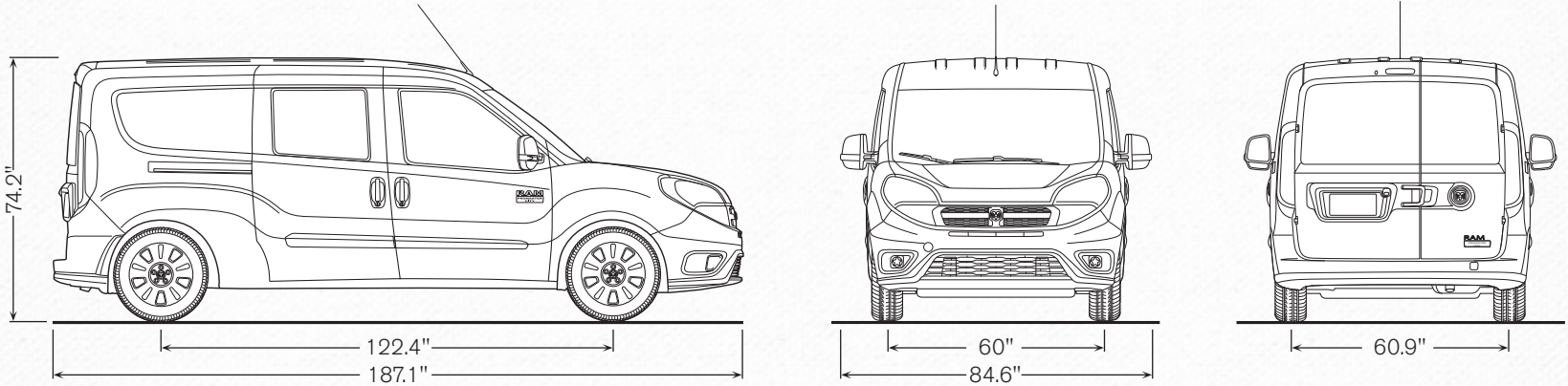

DIMENSIONS

(in inches unless otherwise noted)

	TRADESMAN CARGO VAN	TRADESMAN SLT CARGO VAN	WAGON	WAGON SLT
CARGO HEIGHT	51.8	51.8	48.7	48.7
CARGO VOLUME (cu ft) (behind 2nd-row seats on Wagon / 2nd-row seats folded on Wagon)	131.7	131.7	74.1 / 101.7	74.1 / 101.7
DOOR OPENING HEIGHT – REAR CARGO	47.4	47.4	46.4	46.4
– SIDE SLIDING	43.6	43.6	42.7	42.7
DOOR OPENING WIDTH – REAR CARGO	48.6	48.6	48.6	48.6
– SIDE SLIDING	25.8	25.8	21.2	21.2
HEAD ROOM – FIRST-ROW	45.8	45.8	45.8	45.8
– SECOND-ROW	–	–	44	44
HEIGHT – OVERALL	74.2	74.2	74.2	74.2
HIP ROOM – FIRST-ROW	52.8	52.8	52.8	52.8
– SECOND-ROW	–	–	59.2	59.2
LEG ROOM – FIRST-ROW	40.8	40.8	40.8	40.8
– SECOND-ROW	–	–	36.8	36.8
LENGTH – LOAD FLOOR (behind 2nd-row seats on Wagon / 2nd-row seats folded on Wagon)	87.2	87.2	54.7 / 69.2	54.7 / 69.2
LENGTH – OVERALL BODY	187.1	187.1	187.1	187.1
REAR DOOR LIFT-IN HEIGHT	23.3	23.3	23.8	23.8
SIDE DOOR STEP-IN HEIGHT	21.5	21.5	19.3	19.3
WHEELBASE	122.4	122.4	122.4	122.4
WIDTH – BETWEEN WHEEL WELLS	48.4	48.4	48.4	48.4
– MAXIMUM BETWEEN SIDE PANELS	60.4	60.4	57.6	57.6
– VEHICLE (including mirrors)	84.6	84.6	84.6	84.6

EXTERIOR COLORS



Silver Metallic



Quartz Gray Metallic



Blue Night Metallic



Deep Red Metallic



Bright White



Broom Yellow



Bright Red



Black Metallic

WHEELS



16-inch Steel Wheel painted Silver with Center Cap
Standard on Tradesman® Cargo Van/Wagon



16-inch Steel Wheel with full-painted Silver Wheel Cover
Standard on SLT Cargo Van/Wagon;
Available on Tradesman Cargo Van/Wagon



16-inch Aluminum Wheel
Available on SLT Cargo Van/Wagon

INTERIOR FABRICS

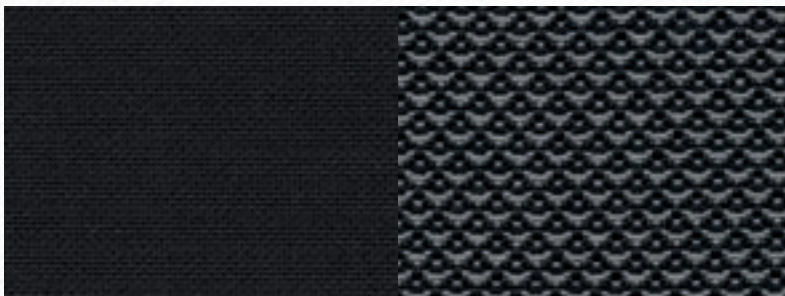

Black Cloth
Standard on Tradesman Cargo Van/Wagon

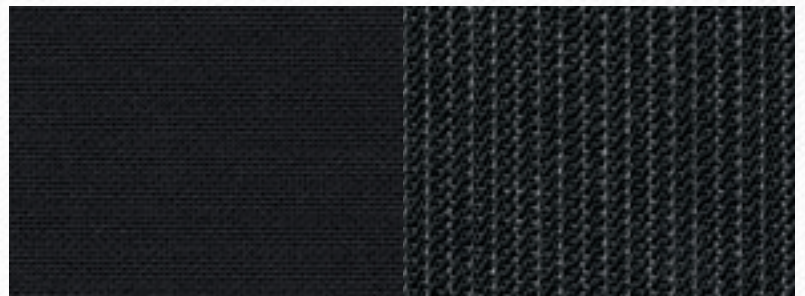

Premium Black Cloth
Standard on SLT Cargo Van/Wagon

BUSINESS LINK

The fast lane for small business.

THE DEALER NETWORK FOR YOUR BUSINESS.

Your **BusinessLink** dealer is committed to providing you, the small business owner, with the vehicle support you need for your business; from servicing all makes and models of your existing vehicles to selling you the right vehicles needed to perform the work that you do. Your **BusinessLink** dealer provides next-bay-up available service because we know downtime is costing you money. Your **BusinessLink**

dealer has sales professionals trained to properly "job-rate" the right vehicle for your work application along with providing commercial finance options. New vehicle sales to qualified small business owners also receive a free alternate transportation contract, in the event your vehicle is in for service.

Membership in the **BusinessLink** program is complimentary. Membership helps us to identify you as a small business owner so we can provide you with both the service you deserve and update you with offers that can help reduce the cost of doing business. Ask your **BusinessLink** dealer to register today.

BusinessLink has you covered.

- ▶ **Next-Bay-Up Service (all makes and models)**
- ▶ **A Dedicated BusinessLink Staff**
- ▶ **Commercial Vehicles in Stock**
- ▶ **Free Loaners* for Selected Vehicles**
- ▶ **Extended Service Hours**
- ▶ **Convenient Shuttle Services**

For more information, log on to **FCAWORKVEHICLESUS.com** or call us toll-free at **877-2THELINK (877-284-3546)**.

*Some restrictions apply. See dealer for details.

ON THE JOB**INCENTIVES FOR SMALL BUSINESSES.**

Running a business presents plenty of challenges. Like

cutting costs, not corners. Like saving time and money and eliminating hassles. The **ON THE JOB**¹⁰ commercial incentive program provides assistance in customizing and servicing your business vehicles.

Our most popular **ON THE JOB**¹⁰ incentives are:

- ▶ **COMMERCIAL EQUIPMENT / UPGRADES.** \$500 / \$1,000 Allowances for Upfits.
 - ▶ **COMMERCIAL GRAPHICS ALLOWANCES.** \$250 / \$500 / \$1,000 Commercial Graphics Allowances.
 - ▶ **BOSCH® TOOL OFFER.** Select one of five current Bosch Power Tool Packages.
 - ▶ **TWO-YEAR LUBE / OIL / FILTER.** For all Chrysler, Jeep®, Dodge and Ram vehicles (includes gas and diesel engines).
 - ▶ **MOPAR® SERVICE CONTRACTS.** \$500 / \$1,000 and Oil Change options available.
- See your dealer for specific program rules and details or call us toll-free at **877-ONTHEJOB (877-668-4356)**.

A commercial line of credit from Chrysler Capital is ideal for qualified business customers looking for a flexible, easy way to manage growing vehicle needs. Chrysler Capital streamlines the process. With prequalification, you're ready to buy a vehicle when you need it. Ask your **BusinessLink** dealer for details.

CHRYSLER CAPITAL

RAM **OUTFITTER**
RAMTRUCKS.COM/OUTFITTER

1 Based on latest available competitive information. Class is Small Commercial Van segment. 2 Efficiency based on best-in-class payload, cargo capacity and fuel efficiency on Ram ProMaster City. Class is Small Commercial Van segment. 3 Transferable. See your dealer for complete details and a copy of the 5-Year/60,000-Mile Powertrain Limited Warranty. 4 The Advanced Front Air Bags in this vehicle are certified to the new U.S. Federal regulations for advanced air bags. Children 12 years old and younger should always ride buckled up in a rear seat. Infants in rear-facing child restraints should never ride in the front seat of a vehicle with a passenger front air bag. All occupants should always wear their lap and shoulder belts properly. 5 Always look before proceeding, electronic drive aid is not a substitute for conscientious driving; always be aware of your surroundings. 6 No system, no matter how sophisticated, can repeal the laws of physics or overcome careless driving actions. Performance is limited by available traction, which snow, ice and other conditions can affect. When the ESC warning lamp flashes, the driver needs to use less throttle and adapt speed and driving behavior to prevailing road conditions. Always drive carefully, consistent with conditions. Always wear your seat belt. 7 Requires a mobile phone equipped with the Bluetooth Hands-Free Profile. Visit UconnectPhone.com for system and device compatibility. 8 SiriusXM subscriptions for audio and data services are sold by SiriusXM to follow your trial subscription. **If you decide to continue listening after your trial, the subscription plan you choose will automatically renew thereafter and you will be charged according to your chosen payment method at then-current rates.** Fees and taxes apply. To cancel, you must call SiriusXM at 1-866-635-2349. See the SiriusXM Customer Agreement for complete terms and more information at siriusxm.com. All fees and programming subject to change. Your equipment and features for SiriusXM services will vary depending upon the vehicle you select and may be limited in select markets. 9 WiFi subscription required. This feature is not intended for use by the driver while the vehicle is in motion. Always drive carefully. 10 ON THE JOB is a retail incentive program; see your dealer for official rules. Inquire about eligibility by calling 877-ONTHEJOB or by logging on to fcaworkvehiclesus.com. The purchaser or lessee must be a qualified commercial customer for more than 30 days prior to the date of the vehicle purchase. An official ON THE JOB Customer Acknowledgment Form must be signed by the customer (provided by the dealer).

©2016 FCA US LLC. All Rights Reserved. Chrysler, Dodge, Jeep, Ram, Mopar, Automobility Program, the BusinessLink design, ParkSense, ParkView, the Ram's Head logo, Ram ProMaster City, Tigershark, Tradesman and Uconnect are registered trademarks and the On The Job design is a trademark of FCA US LLC. Chrysler Capital is a registered trademark of FCA US LLC and licensed to Santander Consumer USA Inc. MultiAir is a registered trademark of C.R.F. Società Consortile per Azioni, used under license by FCA US LLC.

Bluetooth is a registered trademark of Bluetooth SIG, Inc. Sirius, XM and all related marks and logos are trademarks of Sirius XM Radio Inc. Bosch is a registered trademark of Robert Bosch GmbH. Facebook and logo are registered trademarks of Facebook, Inc. The Twitter logo is a service mark of Twitter, Inc. The YouTube logo is a registered trademark of Google Inc. Instagram and logo are registered trademarks of Instagram, Inc. Bontrager is a registered trademark of Trek Bicycle Corporation. Thule is a registered trademark of Thule, Inc. Katerack is a registered trademark of Dejana Truck & Utility Equipment Co. All rights reserved.

About this catalog: since the time of printing, some of the information you'll find in this catalog may have been updated. Ask your dealer for details. Some of the equipment shown or described throughout this catalog may be available at extra cost. Specifications, descriptions, illustrative materials and all competitive comparisons contained herein are as accurate as known at the time this publication was approved for printing. FCA US LLC reserves the right to discontinue models at any time or change specifications without notice or without incurring obligation. Options may be required in combination with other options. For the price of the model with the equipment you desire, or verification of specifications contained here, see your Ram ProMaster City dealer.



Join our community on Facebook, submit your photos on Instagram, follow us on Twitter and check us out on YouTube.



Join fellow Ram enthusiasts and tell your story by posting comments, participating in discussions and sharing your photos and videos.



**131.7-CU FT
CARGO
CAPACITY¹**

Cargo Van



**1,883-LB
MAXIMUM
PAYLOAD¹**

Cargo Van



**48.4-INCH
CARGO WIDTH**
between wheel wells¹



**178 HP¹
174 LB-FT OF
TORQUE¹**
2.4L TIGERSHARK[®]
MULTIAIR[®] 2 I-4



HWY FUEL ECONOMY¹
28 MPG HWY*
2.4L TIGERSHARK
MULTIAIR[®] 2 I-4

*EPA estimated 21 mpg city/28 mpg hwy.
Actual results may vary.



Unsurpassed
**2,000-LB
MAXIMUM
TOWING¹**

Cargo Van
When properly equipped



**NINE-SPEED
AUTOMATIC
TRANSMISSION¹**



**BI-LINK REAR
SUSPENSION¹**
OUTSTANDING COMFORT,
ENHANCED STABILITY



Convenient
**60/40 SPLIT
REAR DOORS**
that open 180 degrees
designed to accept
a standard pallet

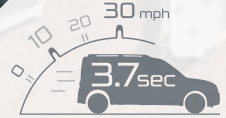

**0-30 MPH
IN 3.7 SEC**



Up to
**10,000-MILE
ENGINE
OIL CHANGE
INTERVALS**

**AMERICA'S
MOST EFFICIENT
WORK VAN²**



Available
**5-INCH
UCONNECT[®]
TOUCHSCREEN**

RAMTRUCKS.COM/PROMASTERCITY



**RAM
COMMERCIAL**