

PROMASTER LIGHTING

GENERAL INFORMATION

The ProMaster has been designed and developed using European Spec incandescent lights. These lights are controlled by a computerized module called the “Body Control Module” (BCM). This module controls the left and right head lights, left and right DRL, the left and right front and rear running lights, the left and right front and rear turn signals, and the left, right and center brake lights, and the reverse lights independently. The BCM utilizes “smart” technology that has the ability to monitor the current (amperage) on some of the lighting outputs.

These monitored outputs include the headlamps, DRL, turn lamps, running lamps, brake lamps, reverse lamps and license plate lamp. The module is able to detect both electrical short and open (bulb out) circuit conditions. The module has a preset allowable current (amperage) operating range for each of these outputs. If while in normal operation the current detected falls outside this preset range, then a fault is set in the BCM. In the case of too high of current the circuit will be shut off. This fault condition will remain true until the current level falls back into the normal range. In the case of the turn lamp circuits, if the module detects too low of current then the module will assume an open circuit condition (burned out bulb) and the blinker will flash at a double flash rate. This detection is in place to assist the customer in determining if there is an active short in the lighting circuit or a burned out bulb (open circuit).

For the van, the rear lighting has separated stop and turn. This means that the stop signal and the turn signal use separate bulbs. In the chassis cab and cut away, the rear lighting is combined, meaning that the stop lamp bulb and the turn lamp bulb both function as stop and turn signals. In this case, there two separate bulbs in each side driven by separate drivers in the BCM. The BCM is programmed so that both bulbs function as stop and turn signals.

Fault conditions can be encountered by adding additional lamps to the circuits or by changing the lamp specifications (i.e. changing the type of lamp used). This would include, but is not limited to, the use of LED’s. By using them you run the risk of causing lighting faults or loss of lighting functionality. The question then becomes, “can you use LED lighting on ProMaster”? The answer is yes, but special care and procedures need to be followed to use LEDs successfully.

The CHASSIS utilizes a 12 way in line harness connector to separate the rear lighting harness from the chassis harness. Description of the connector is on page 2.

PROMASTER LIGHTING

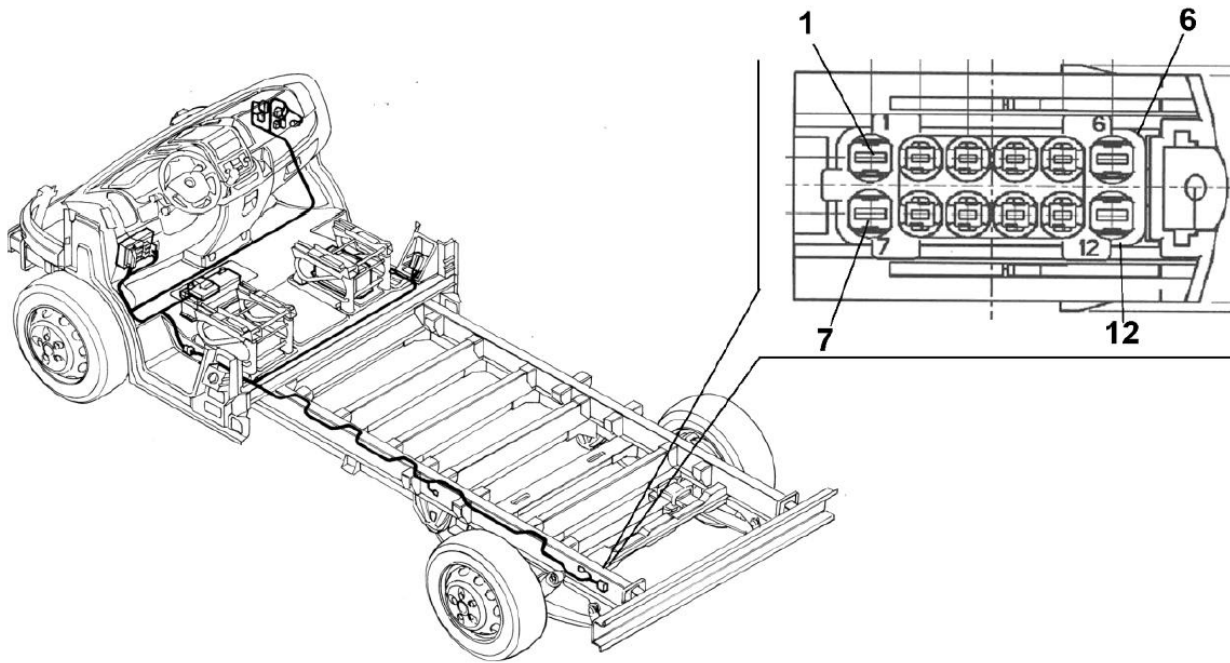

Chassis Harness Connector – Tyco P/N 284844-1

Tail Light Harness Connector – Tyco P/N 254848-3

Pin	Function	Min Wire Section (mm ²)	Wire Color	Notes
1	Not Connected			
2	Left Rear Running Light	0.35	YL/VT	2 – 5 W Bulbs
3	Right Rear Running Light	0.35	YL/BK	2 – 5 W Bulbs
4	Left Rear Turn Light ^{Note 1}	0.5	BL/WT	1 – 30 W Bulb
5	Right Rear Turn Light ^{Note 2}	0.5	BL/BK	1 – 30 W Bulb
6	Left Stop Light ^{Note 1}	0.5	VT/BK	1 – 35 W Bulb
7	Right Stop Light ^{Note 2}	0.5	VT	1 – 35 W Bulb
8	Marker Lights	0.5	YL/BK	P _{max} = 21 W @ 12 V
9	Left Reverse Light	0.5	WT/VT	1 – 21 W Bulb
10	Not Connected			
11	License Plate Light	0.5	WT/BL	P _{max} = 10 W @ 12 V
12	Right Reverse Light	0.5	GY/VT	1 – 21 W Bulb

Note 1 - For Chassis Cab, Left Turn and Left Stop Function the Same as Combined Stop/Turn

Note 2 - For Chassis Cab, Right Turn and Right Stop Function the Same as Combined Stop/Turn

PROMASTER LIGHTING

REPLACING REAR INCANDESCENT BULBS WITH LED'S

Note: It is not recommended that you replace the rear lighting in a VAN.

If you wish to use LEDs to replace the rear lighting on ProMaster CHASSIES built after 5/15/15, The BCM software can be configured to disable the bulb out detection. (BOD) There are three methods for disabling BOD. They are listed below.

- Vehicle can be built from factory with BOD disabled by ordering sales code **LB6**
- BOD can be disabled by dealer with dealer installed sales code **5QP**. After 5QP is added, the BCM Proxi must be reconfigured.
- BOD can be disabled by customer/up fitter by performing the following "Chicken Dance." All steps must be performed within 30 seconds. BOD can be re-enabled by repeating the steps.
 - Key ON
 - Check for Turn Signals OFF
 - Brake Pedal Pressed
 - Shift Transmission to Reverse
 - Pull High Beam Stalk for >10s
 - Release High Beam Stalk
 - Release Brake Pedal
 - Shift transmission to park/neutral

If you wish to use LEDs to replace the rear lighting on a ProMaster CHASSIES built 5/15/15 and earlier, Power resistors must be used in order to eliminate bulb out detection faults. Add power resistors to the rear light circuits as specified as follows.

In Line Connector Pin	Function	Wire Color	Resistance	Bulb Wattage
4	Left Stop/Turn Signal	BL/WT	10 Ohm	30 W Bulb
5	Right Stop/Turn Signal	BL/BK	10 Ohm	30 W Bulb
6	Left Stop/Turn Signal	VT/BK	8.2 Ohm	35 W Bulb
7	Right Stop/Turn Signal	VT	8.2 Ohm	35 W Bulb

The resistors all should be 50 Watt and should be wired in parallel with the LED lamp attached to each brake and turn circuit. The resistors must be capable of surviving exterior exposure on the vehicle with consideration for vibration and expected life cycle. As power resistors may get hot under normal operation it is suggested that they be placed in an area with adequate ventilation and heat dissipation. It is further suggested that they be located very near the LED's; this is to help with any future service related maintenance or repairs to the lighting circuits.

USE OF LEDS IN CONJUNCTION WITH THE O.E. LAMPS

If you are keeping the O.E. incandescent lamps on a VAN or CHASSIS and you want to add additional LED lamps for use as stop, turn, reverse or park lamp function you can do so with no additional changes to the vehicle or its electrical system.

PROMASTER LIGHTING

ADDING ADDITIONAL INCANDESCENT LAMPS TO THE O.E. LAMPS

As a general statement the BCM does not provide a large enough current range on the head, turn, stop or reverse lamp circuits to add any additional incandescent lamp loads. It is therefore strongly recommended that the following procedures are followed for modifying the exterior lighting. If you are keeping the O.E. incandescent lamps on a VAN or CHASSIS and you want to add additional incandescent lamps, it is possible but it requires adding a relay to control the additional lamps. By correctly wiring the relay into the lighting circuit you only add the additional coil resistance of the relay. With most relays, this will maintain the correct operating current (amp) range of the circuits and no faults will be set. A relay will need to be added to each circuit you attempting to add lights to. The figure below shows the basic connection of a relay. If you would rather not wire and package individual relay's you could connect the additional lighting to the vehicle's trailer tow circuits. If you vehicle does not have trailer tow from the factory, the trailer tow kit can be purchased from your dealer. The part number for the Van kit is 82213930AA, AB, or AC. The part number for the chassis kit is 82214282AB.

When using the trailer tow circuits or adding your own relays, please understand that there is no way for the vehicle to perform any diagnostics on the added lamps.

