

2015 UPFITTER SCHEMATIC

3500/4500/5500 CHASSIS CABS RAM Truck Upfitter Schematic

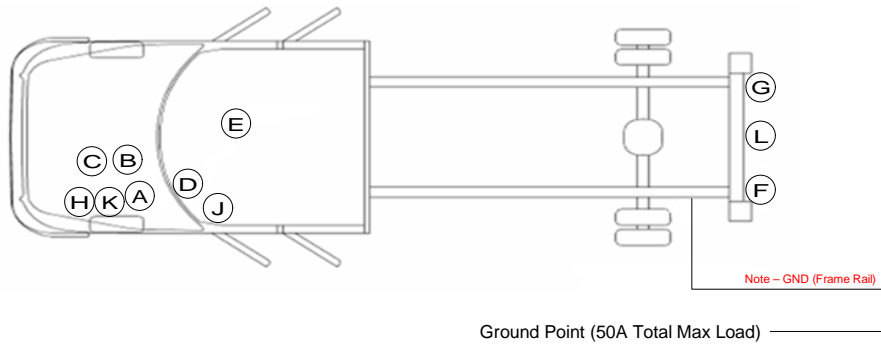

- (A) Note – Aux PDC (auxiliary Power Distribution Center-relay/fuse box) Underhood
- (B) Note – 2 Upfitter Connectors (Light and Dark Gray)
- (C) PDC (main Power Distribution Center-relay/fuse box) underhood
- (D) Note – Port Upfitters Connectors, Under Dash Board near park brake bracket / Steering Column
- (E) Note – PTO Connector Wires located underneath vehicle at Transmission Bell Housing, Left (Driver) Side
- (F)(G) Note – Vehicle Wiring, Blunt Cut (with Heat Shrink) Rear of Frame
- (H) Note – Blunt Cut (with Heat Shrink) wires underneath the PDC (C)
- (J) Note – VSIM Module located interior of vehicle under dash
- (K) Note – Aux 5/PTO jumper connector, alongside left (Drivers Side) fender inner
- (L) Rear Camera Connector

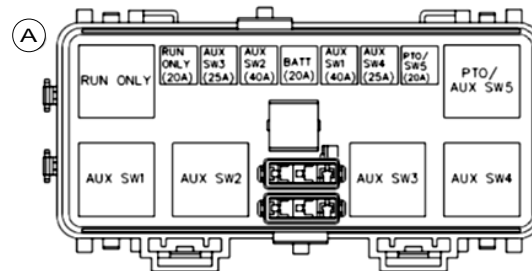

The auxiliary switch function logic (BATTERY or IGNITION FED, MOMENTARY or LATCHING, LAST STATE) is programmed using the EVIC display in the instrument cluster.

Notes –
 Max Combined Fuse "rating" allowed in box is 190A. Fuses can be relocated in box as necessary.
 Max allowable combined total continuous amperage draw is 133A.
 Max fuse "rating" in any one location is 40A.

*The upfitter/customer is responsible for placing the correct fuse in the correct location depending on the actual load.

*Amperages shown in schematics are for fuses/circuits as installed for the vehicle as sold and will change as fuses are reconfigured.

MAX ALLOWABLE
CONTINUOUS AMPERAGE
DRAW PER FUSE RATING

FUSE RATING	MAX ALLOWABLE CONTINUOUS AMPERAGE
20A	14A
25A	17.5A
40A	28A

2015 UPFITTER SCHEMATIC

2500/3500 PICKUP RAM Truck Upfitter Schematic

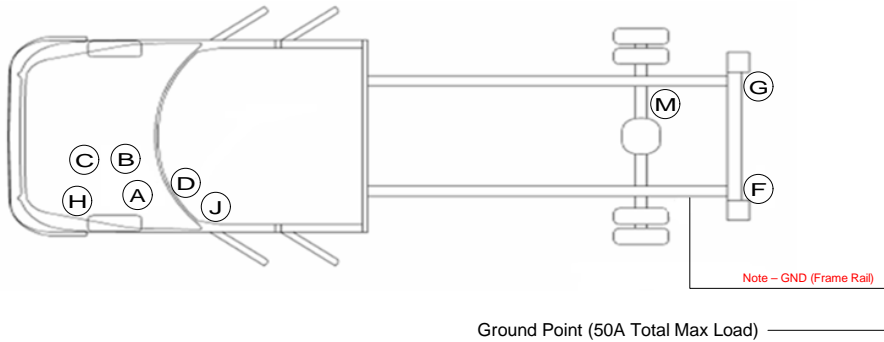

- (A) Note – Aux PDC (auxiliary Power Distribution Center-relay/fuse box) Underhood
- (B) Note – 2 Upfitter Connectors (Light and Dark Gray)
- (C) PDC (main Power Distribution Center-relay/fuse box) underhood
- (D) Note – Port Upfitters Connectors, Under Dash Board near park brake bracket / Steering Column
- (E) Note – Vehicle Wiring, Blunt Cut (with Heat Shrink) Rear of Frame
- (F) Note – Blunt Cut (with Heat Shrink) wires underneath the PDC (C)
- (G) Note – VSIM Module located interior of vehicle under dash
- (H) Note – Blunt Cut (with Heat Shrink) Stop Lamp Signal – CHMSL Feed
- (J)
- (M)

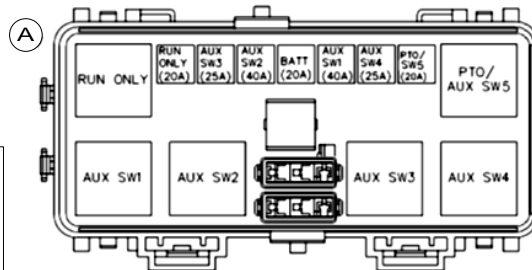

The auxiliary switch function logic (BATTERY or IGNITION FED, MOMENTARY or LATCHING, LAST STATE) is programmed using the EVIC display in the instrument cluster.

Notes –
 Max Combined Fuse "rating" allowed in box is 190A. Fuses can be relocated in box as necessary.
 Max allowable combined total continuous amperage draw is 133A.
 Max fuse "rating" in any one location is 40A.

*The upfitter/customer is responsible for placing the correct fuse in the correct location depending on the actual load.

*Amperages shown in schematics are for fuses/circuits as installed for the vehicle as sold and will change as fuses are reconfigured.

MAX ALLOWABLE
CONTINUOUS AMPERAGE
DRAW PER FUSE RATING

FUSE RATING	MAX ALLOWABLE CONTINUOUS AMPERAGE
20A	14A
25A	17.5A
40A	28A

2015 UPFITTER SCHEMATIC

3500/4500/5500 CHASSIS CAB
6.7 Diesel Manual Trans w/PTO
(Sales Codes LBN)

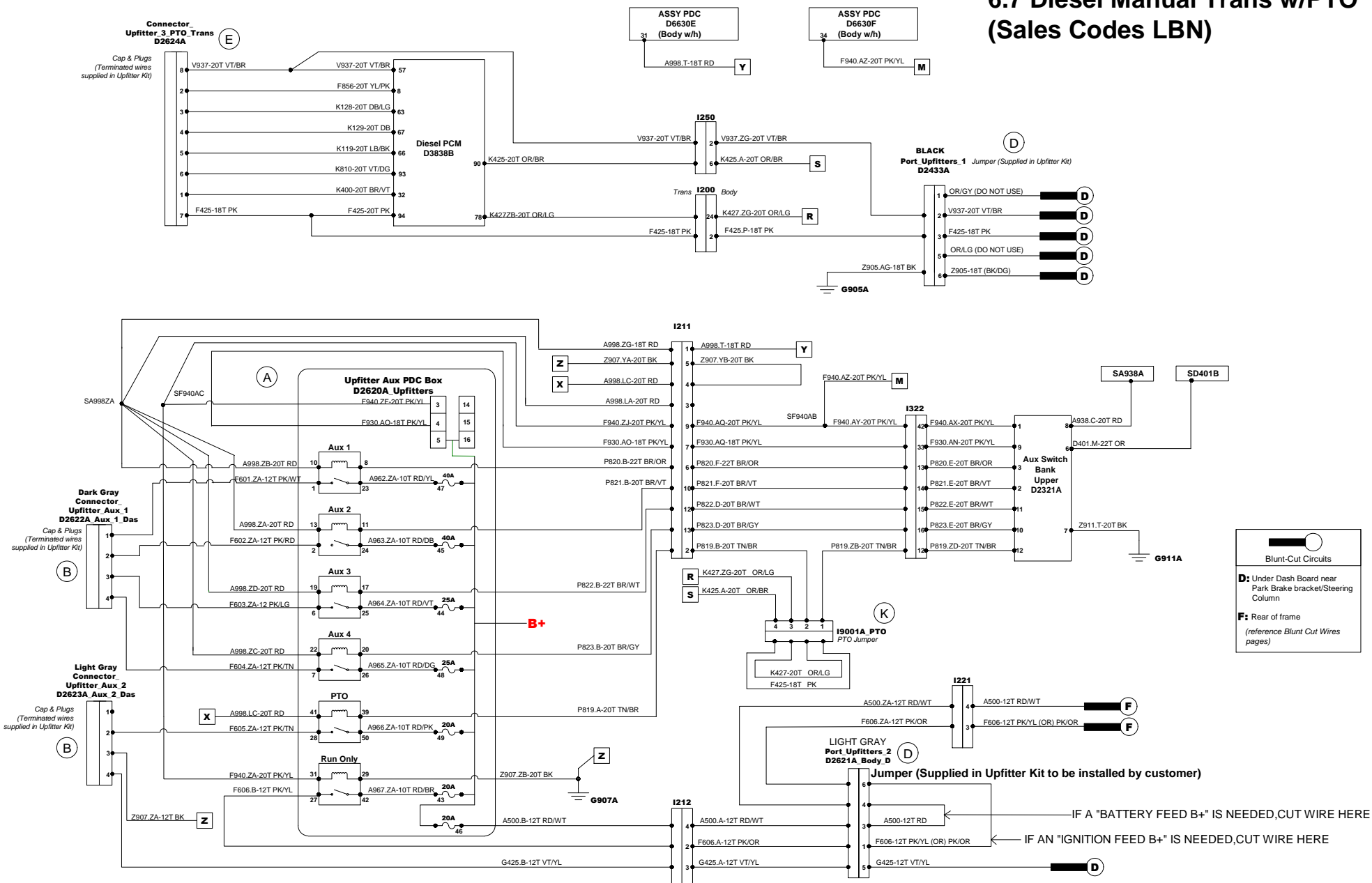

Blunt-Cut Circuits

D: Under Dash Board near Park Brake bracket/Steering Column

F: Rear of frame (reference Blunt Cut Wires pages)

2015 UPFITTER SCHEMATIC

3500/4500/5500 CHASSIS CAB 6.7 Diesel Auto Trans w/PTO (Sales Codes LBN/LBV)

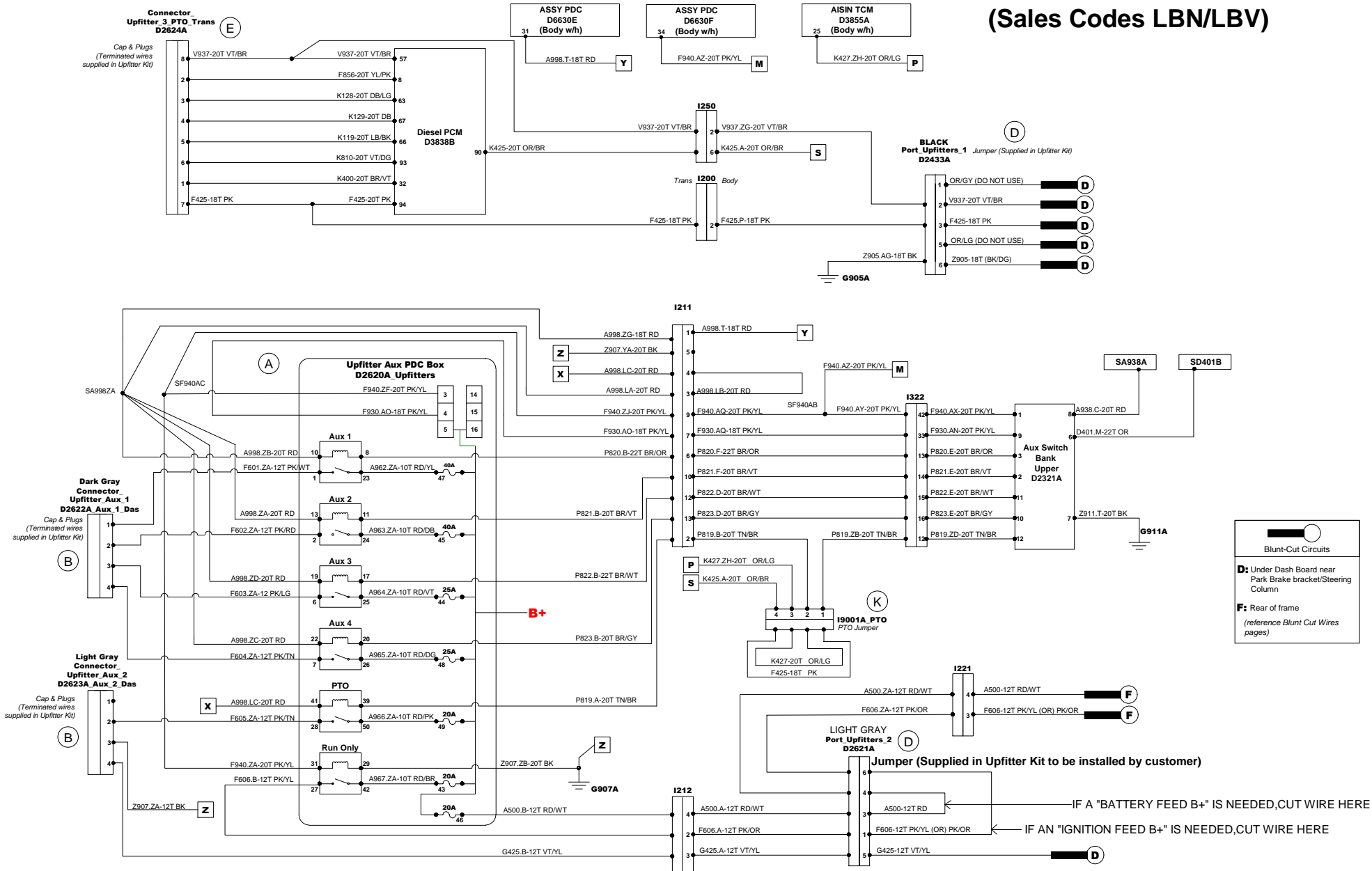

2015 UPFITTER SCHEMATIC

3500/4500/5500 CHASSIS CAB 6.4 Gas Aisin Trans (ONLY) w/PTO (Sales codes LBN/LBV)

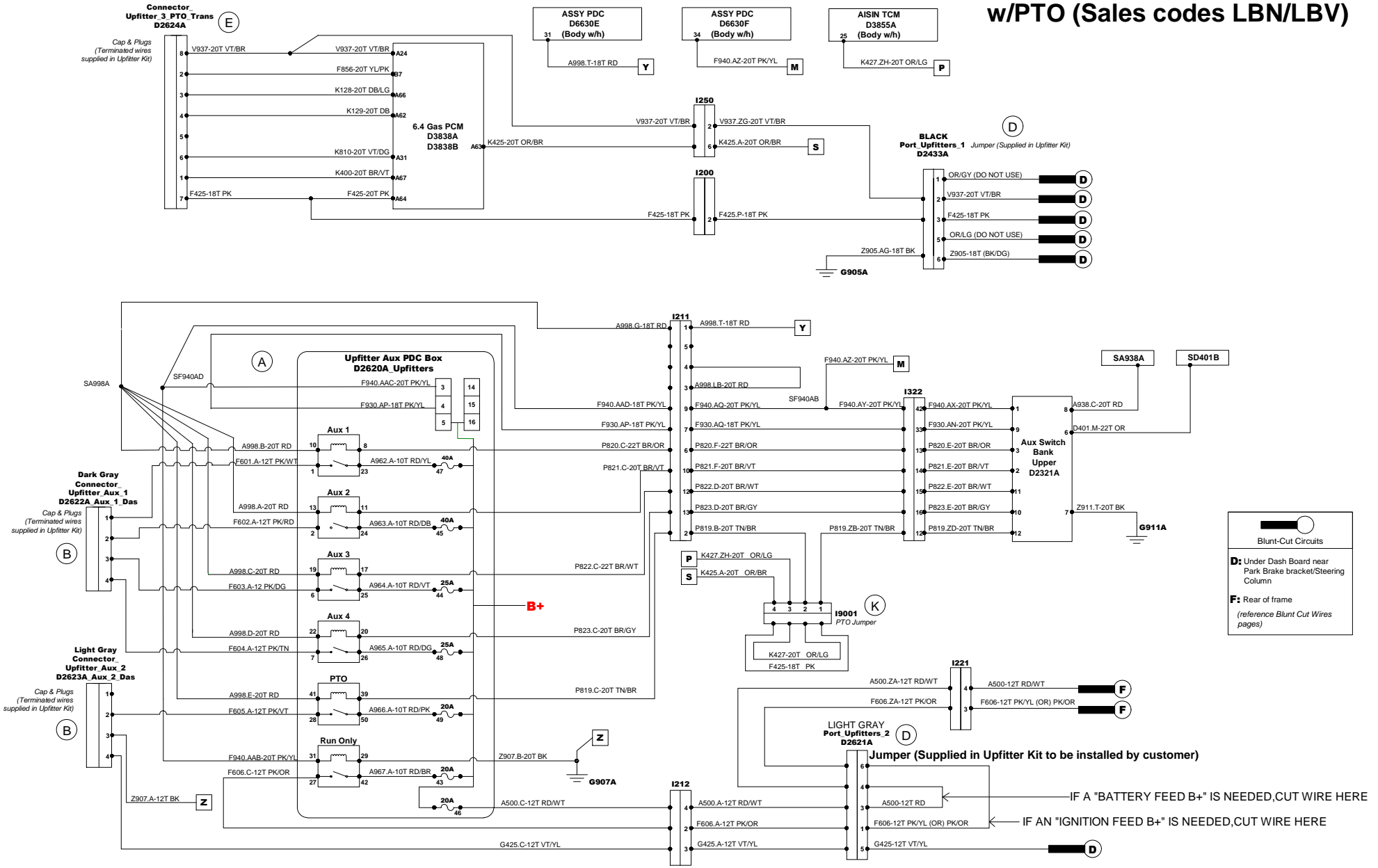

2015 UPFITTER SCHEMATIC

3500/4500/5500 CHASSIS CAB
6.7 Diesel Manual Trans non-PTO

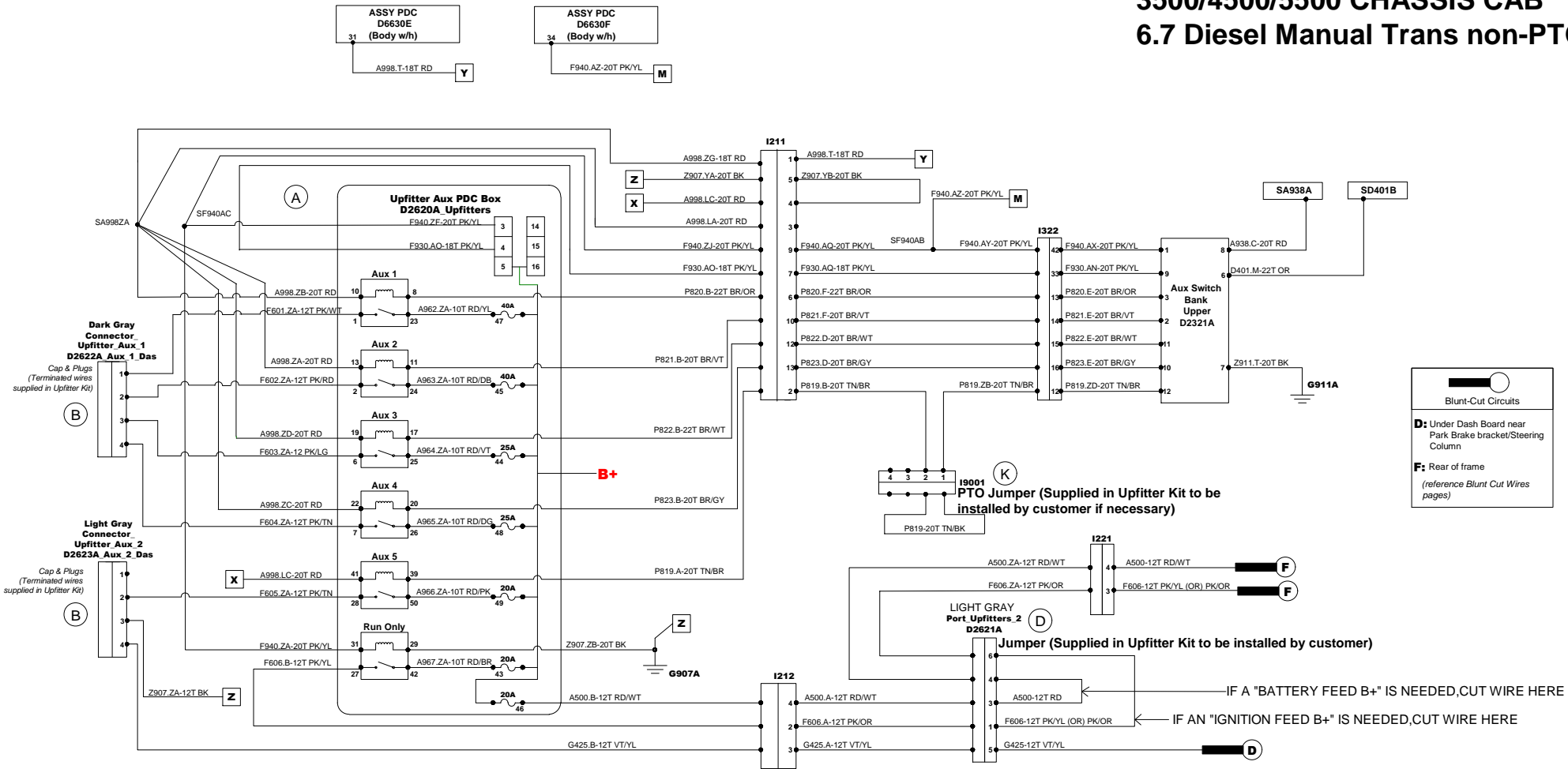

2015 UPFITTER SCHEMATIC

3500/4500/5500 CHASSIS CAB 6.7 Diesel Auto Trans Non - PTO

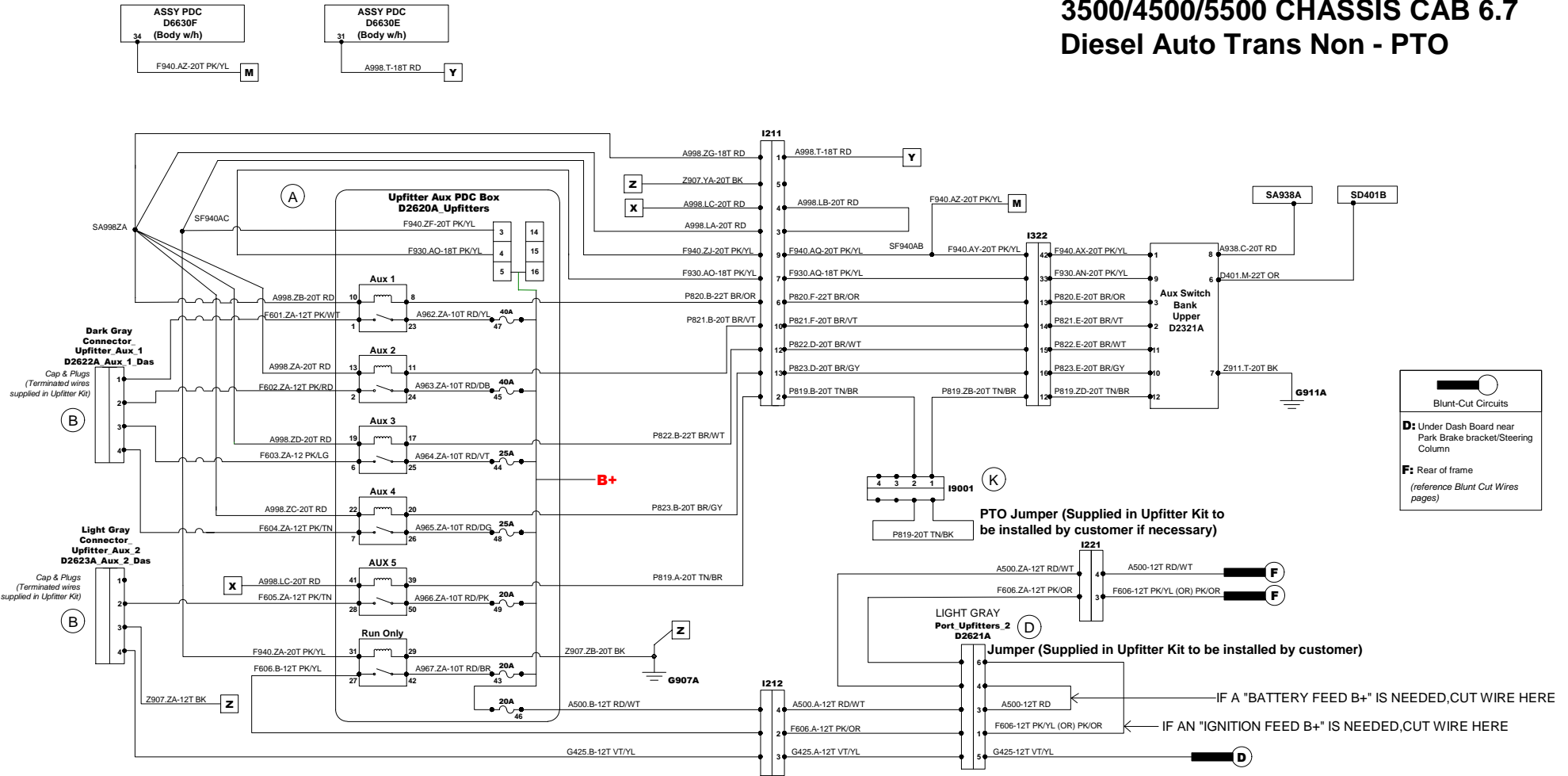

2015 UPFITTER SCHEMATIC

3500/4500/5500 CHASSIS CAB 5.7/6.4 GAS Auto Trans Non - PTO

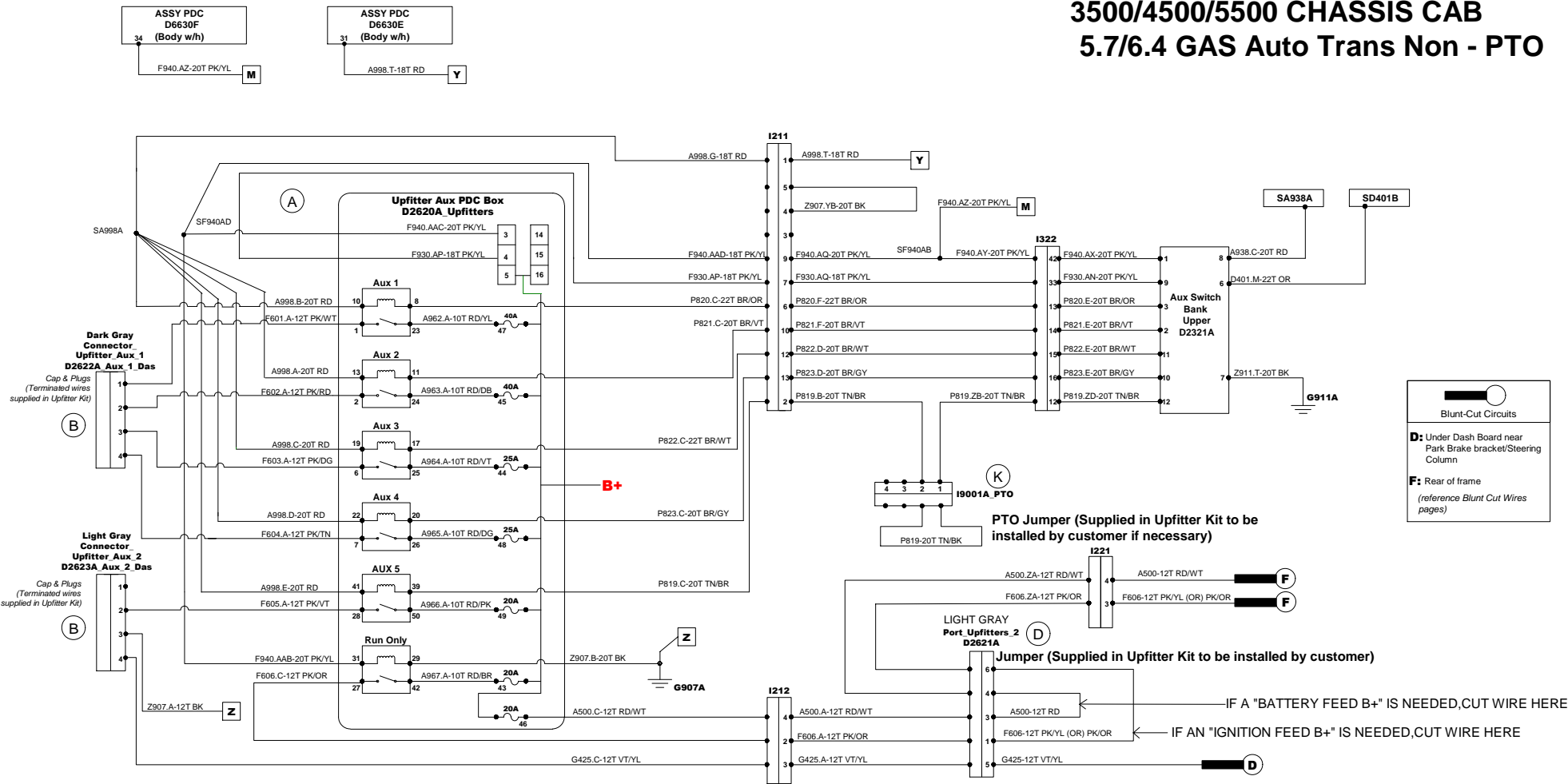

2015 UPFITTER SCHEMATIC

2500/3500 PICKUP 6.7 Diesel with Auxiliary Switches (Sales Code LHL)

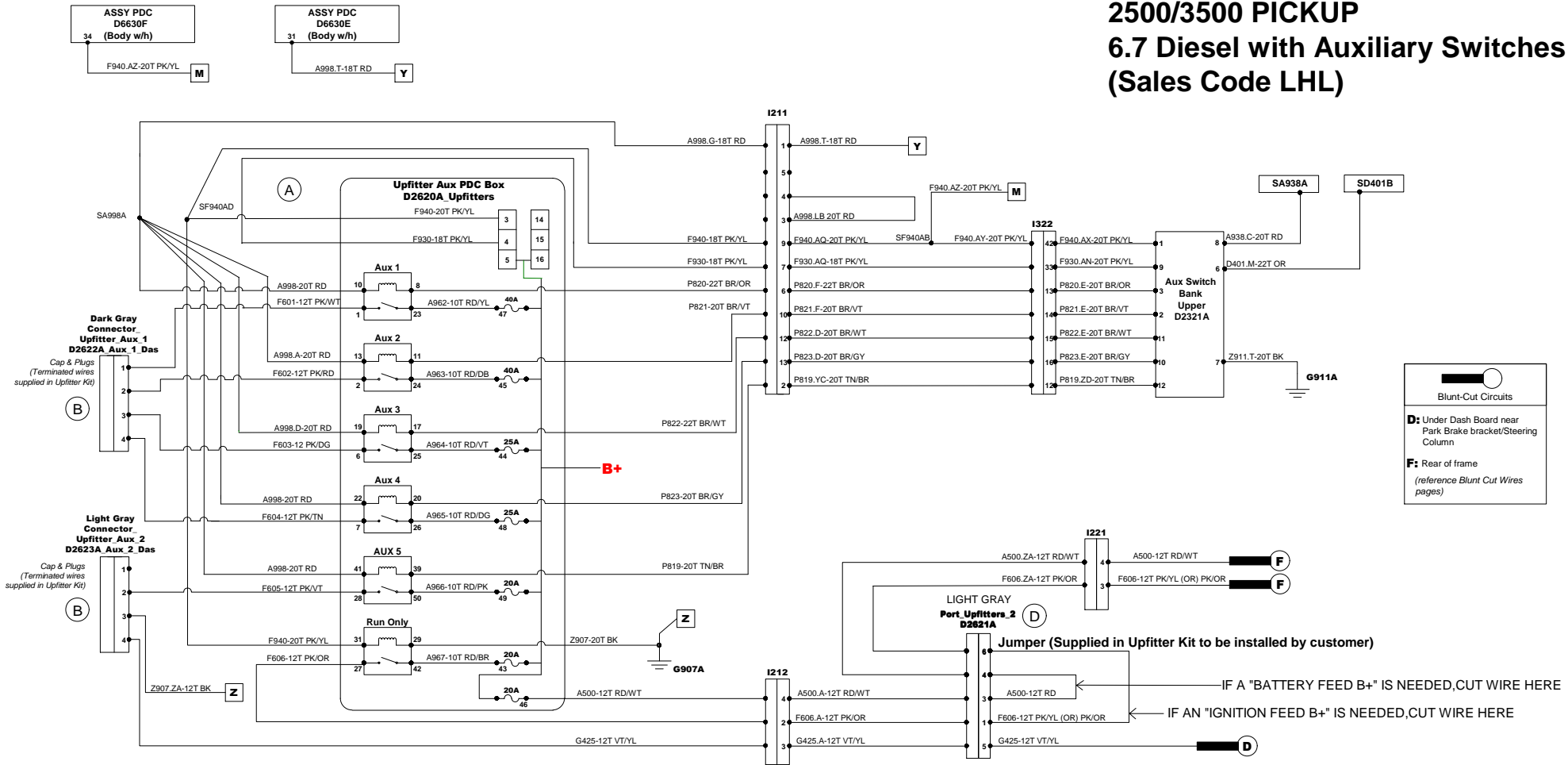

2015 UPFITTER SCHEMATIC

2500/3500 PICKUP 5.7/6.4 Gas with Auxiliary Switches (Sales Code LHL)

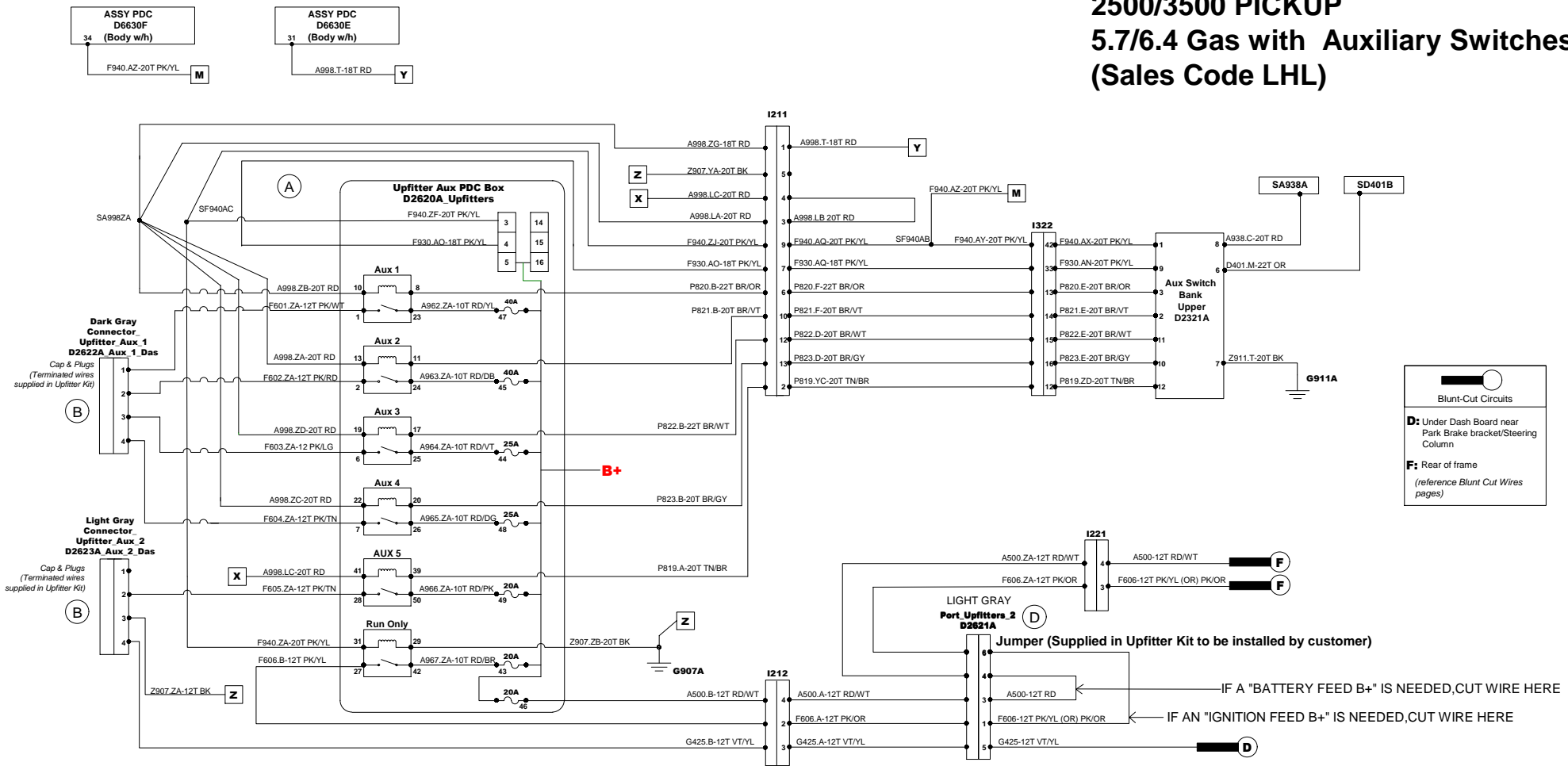

2015 UPFITTER SCHEMATIC

Blunt Cut Wires 3500/4500/5500 CHASSIS CAB

"G" Blunt Cut wires located at Right (Passenger side) Rear of Frame

A100-14T RD/VT (Trailer Tow Battery feed)	G #
B40-14T DG (Electric Brake feed)	G #
L76-16T WT/BR (Trailer Tow Running/Park Lamps feed)	G #
L111-16T WT/OR (Trailer Tow Back-up Lamps feed)	G #
L614-18T LG (Trailer Tow Stop/Turn Right)	G #
L615-18T YL (Trailer Tow Stop/Turn Left)	G #
Z914-12T BK/GY (Ground)	G #

The maximum allowable continuous amperage for these Trailer Tow circuits will be found under "ELECTRICAL/WIRING INFORMATION", "ELECTRICAL POWER USAGE", "AMPERAGE CAPACITY PER CIRCUIT".

"H" Blunt Cut wires located underneath PDC

C

* H	L177-18T WT/BR (PARK LAMP RELAY- LSD)
H	L312-18T BK/VT (SNOW PLOW LIGHTING ENABLE- B+)
* H	L313-18T BK/LG (LOW BEAM RELAY- LSD)
H	L314-18T BK/TN (DO NOT USE)
* H	L315-18T BK/LB (HIGH BEAM RELAY- LSD)
H	L316-18T BK/OR (DO NOT USE)
* H	L317-18T WT/VT (TURN SIGNAL RELAY,LEFT- HSD)
* H	L318-18T VT/BR (TURN SIGNAL RELAY,RIGHT- HSD)
H	T754-22T DG/GY (HARD-WIRED REMOTE START/STOP)
* H	T120-20T DG/OR (TRANS PARK POSITION DETECTION)
H	L950-20T LG/WT (REAR BULB OUTAGE DETECTION DISABLE)
H	L779-18T WT/LB (SEPARATE REAR STOP / TURN LAMPS)

* The maximum allowable continuous amperage for these Snow Plow and T120 circuits will be found under "ELECTRICAL/WIRING INFORMATION", "ELECTRICAL POWER USAGE", "AMPERAGE CAPACITY PER CIRCUIT".

VEHICLE WIRING

V937-20T VT/BR (Speed Control Switch return)	D
F425-18T PK (PTO switch)	D
Z905-18T BK/DG (Ground)	D
G425-12T VT/YL (Power takeoff status bulb)	D

"D" Blunt Cut wires are part of the Upfitter Ports 1 & 2 Jumpers located under Dash near Park Brake Bracket/Steering Column. Connectors (Black & Gray) for these circuits are part of the Upfitter Jumper kit.

** These two circuits become active when the 6 cavity Light Gray connector (Jumper port Upfitter 2) included in the upfitter kit is installed onto the Light Gray connector at location 'D' in the vehicle diagram

** A500-12T RD/WT (Battery feed)	F
** F606-12T PK/OR (Ignition Run feed)	F
L56-18T WT/VT (Stop Lamp signal / CHMSL feed)	F

"F" Blunt Cut wires located at Left(Drivers Side) Rear of Frame

2015 UPFITTER SCHEMATIC

Blunt Cut Wires

2500/3500 Pickup Box-off (Sales Code XBC & LHL)

"G" Blunt Cut wires located at Right (Passenger Side) Rear of Frame

"M" Blunt Cut wire located at Right (Passenger Side), in the second crossmember from rear to front.

M L56-18T WT/VT (Stop Lamp signal / CHMSL feed)

- A100-14T RD/VT (Trailer Tow Battery feed) **G**#
- B40-14T DG (Electric Brake feed) **G**#
- L76-16T WT/BR (Trailer Tow Running/Park Lamps feed) **G**#
- L111-16T WT/OR (Trailer Tow Back-up Lamps feed) **G**#
- L614-18T LG (Trailer Tow Stop/Turn Right) **G**#
- L615-18T YL (Trailer Tow Stop/Turn Left) **G**#
- Z914-12T BK/GY (Ground) **G**#

The maximum allowable continuous amperage for these Trailer Tow circuits will be found under "ELECTRICAL/WIRING INFORMATION", "ELECTRICAL POWER USAGE", "AMPERAGE CAPACITY PER CIRCUIT".

"H" Blunt Cut wires located underneath PDC

C

- * H L177-18T WT/BR (PARK LAMP RELAY- LSD)
- H L312-18T BK/VT (SNOW PLOW LIGHTING ENABLE- B+)
- * H L313-18T BK/LG (LOW BEAM RELAY- LSD)
- H L314-18T BK/TN (DO NOT USE)
- * H L315-18T BK/LB (HIGH BEAM RELAY- LSD)
- H L316-18T BK/OR (DO NOT USE)
- * H L317-18T WT/VT (TURN SIGNAL RELAY,LEFT- HSD)
- * H L318-18T VT/BR (TURN SIGNAL RELAY,RIGHT- HSD)
- H T754-22T DG/GY (DO NOT USE)
- * H T120-20T DG/OR (TRANS PARK POSITION DETECTION)
- H L950-20T LG/WT (REAR BULB OUTAGE DETECTION DISABLE)
- H L779-18T WT/LB (DO NOT USE)

VEHICLE WIRING

G425-12T VT/YL (Spare Circuit - Pass Thru) **D**

** These two circuits become active when the 6 cavity Light Gray connector (Jumper port Upfitter 2) included in the upfitter kit is installed onto the Light Gray connector at location 'D' in the vehicle diagram

** A500-12T RD/WT (Battery feed) **F**

** F606-12T PK/OR (Ignition Run feed) **F**

"F" Blunt Cut wires located at Left(Drivers Side) Rear of Frame

* The maximum allowable continuous amperage for these Snow Plow and T120 circuits will be found under "ELECTRICAL/WIRING INFORMATION", "ELECTRICAL POWER USAGE", "AMPERAGE CAPACITY PER CIRCUIT".

"D" Blunt Cut wires are part of the Upfitter Ports 1 & 2 Jumpers located under Dash near Park Brake Bracket/Steering Column. The Connector (Gray) for this circuit is part of the Upfitter Jumper kit.

2015 UPFITTER SCHEMATIC

Blunt Cut Wires 2500/3500 PICKUP Box-on W/Auxiliary Switches (Sales Code LHL)

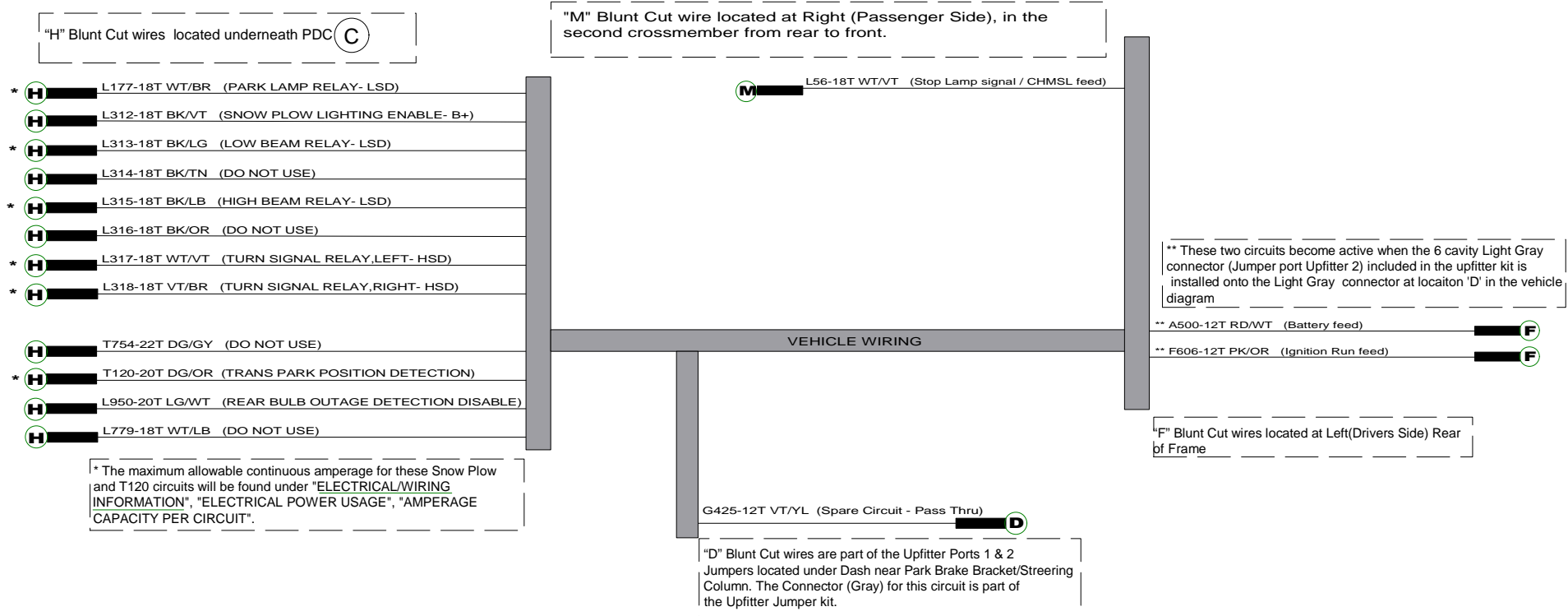









2015 UPFITTER SCHEMATIC

Blunt Cut Wires 2500/3500 PICKUP Box-on W/O Auxiliary Switches

"H" Blunt Cut wires located underneath PDC

(C)

- *  L177-18T WT/BR (PARK LAMP RELAY-LSD)
- *  L312-18T BK/VT (SNOW PLOW LIGHTING ENABLE- B+)
- *  L313-18T BK/LG (LOW BEAM RELAY- LSD)
- *  L314-18T BK/TN (DO NOT USE)
- *  L315-18T BK/LB (HIGH BEAM RELAY- LSD)
- *  L316-18T BK/OR (DO NOT USE)
- *  L317-18T WT/VT (TURN SIGNAL RELAY,LEFT- HSD)
- *  L318-18T VT/BR (TURN SIGNAL RELAY,RIGHT- HSD)

"M" Blunt Cut wire located at Right (Passenger Side), in the second crossmember from rear to front.

(M)

L56-18T WT/VT (Stop Lamp signal / CHMSL feed)

VEHICLE WIRING

* THESE SNOW PLOW CIRCUITS ARE NOT AVAILABLE ON
POWER WAGON WITH "TRU-LOK" AXLES

The maximum allowable continuous amperage for these
Snow Plow circuits will be found under
"ELECTRICAL/WIRING INFORMATION", "ELECTRICAL
POWER USAGE", "AMPERAGE CAPACITY PER CIRCUIT".

2015 UPFITTER SCHEMATIC

Upfitter Jumper Harness Only 68049501AB

PTO Connector

(E)



Dash - Dark Gray
Connector_Upfitter Aux_1

(B)



*Note - Each Circuit can handle maximum continuous current of 28A. Maximum combined load for AUX Switches is 133A
*The upfitter/customer is responsible for placing the correct fuse in the correct location depending on the actual load.

Dash - Light Gray
Connector_Upfitter_2 Aux_2

(B)



1	K400-20T BR/VT (ENG - ACCEL PEDAL POS SNSR RTN 2)
2	F856-20T YL/PK (ENG - 5V ENGINE SNSR FEED SEC)
3	K128-20T DB/LG (ENG - REMOTE THROTTLE SWITCH SIGNAL)
4	K129-20T DB/DG (ENG - REMOTE THROTTLE SWITCH)
5	K119-20T LG/BK (ENG - MAXIMUM OPERATING SPEED SWITCH)
6	K810-20T VT/DG (ENG - ACCELERATOR INTERLOCK SWITCH)
7	F425-20T PK (PWR - POWER TAKEOFF SWITCH)
8	V937-20T VT/BR (SCS - SPEED CTRL SW RTN)

1	F601-12T PK/WT (RELAY 1 OUTPUT)
2	F602-12T PK/RD (RELAY 2 OUTPUT)
3	F603-12T PK/DG (RELAY 3 OUTPUT)
4	F604-12T PK/LB (RELAY 4 OUTPUT)

1	
2	F605-12T PK/YL (RELAY 5 OR PTO RELAY OUTPUT)
3	Z907-12T AWG BK (GND)
4	G425-12T AWG VT/YL (Spare Circuit - Pass Thru)

Jumper
Port_Upfitters_1

(D)



Jumper
Port_Upfitters_2

(D)



1	F606-12T AWG PK/YL (OR) PK/OR (PWR - ATM UPFITTER IGN RUN FEED)
2	
3	A500-12T AWG RD OR RD/WT (PWR - BATT - ATM - UPFITTER FUSED FEED)
4	
5	G425-12T VT/YL (Spare Circuit - Pass Thru)
6	

1	OR/GY (DO NOT USE)
2	V937-20T VT/BR (SCS - SPEED CTRL SW RTN)
3	F425-20T PK (PWR - PTO SWITCH)
4	
5	OR/LG (DO NOT USE)
6	Z905-18T BK/DG (GROUND)

THESE ARE NORMALLY NOT CUSTOMER REPLACED

(K)

Jumper
PTO



1	
2	K427-20T OR/LG
3	
4	F425-18T PK

(K)

Jumper
NON-PTO
(Aux 5)



1	P819 20T TN/BK
2	
3	
4	

2015 UPFITTER SCHEMATIC

PTO CONNECTOR Underweath Vehicle at Transmission Circuit Function and Pin - Out 3500/4500/5500 CHASSIS CAB ONLY

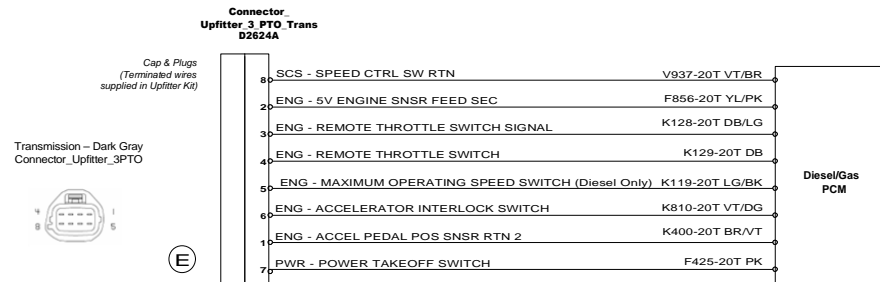

2015 UPFITTER SCHEMATIC

Bagged Upfitter Kit Detail 68209998AB/68209998AC

*Upfitter Connection Jumper

*8 – 12 GA Circuits for Upfitter Aux Connectors 1 & 2

*8 – 20 GA Circuits for the Transmission PTO Connector

*2 – PTO/Non-PTO Jumper Connectors

(1) Port Upfitter Gray Connector w/5 wires

(1) Port Upfitter Black Connector w/5 wires

The Vehicle has been equipped to ease the installation of a PTO by allowing convenient access to circuits needed without having to splice into the main harness.

Located left of Main PDC Box and along the left (Drivers Side) fender inner (location K) is a dark gray jumper connector that allows the vehicle function to switch between PTO and non-PTO operation, although this normally need not be accessed by the customer. If required, the jumpers are located in this upfitter kit. If necessary, verify proper jumper usage by reviewing jumper design on previous pages.

In the rear of the vehicle, you can find all required T-TOW circuits, two (2) additional power circuits (1 Battery and 1 Ignition) and a Stop Lamp / CHMSL Feed Circuit.

In the Engine compartment you will find two (2) (A Light Gray and a Dark Gray) Upfitter AUX connectors (location B) which allow easy access to the switch bank and fuse box outputs, mating terminated circuits are included in this kit as needed. Connectors (Black & Gray) for these circuits are part of the Upfitter jumper kit.

The Battery line to the AUX PDC is protected by a wire fuse link.

Warning about adding auxiliary batteries:

An auxiliary battery may be used, however a battery isolation unit is not supplied and the auxiliary battery may discharge the truck battery when the engine is not running.

Ground Studs on the chassis/frame may be utilized as a grounding point with a 50A Maximum total load, see “Vehicle Ground Locations” section in the RAM Body Builder Guide, Electrical/Wiring Information.