

RAM OCCUPANT RESTRAINT SYSTEM INFORMATION

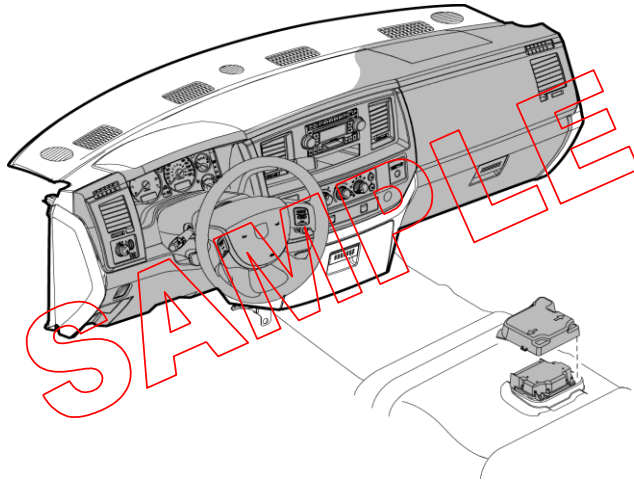

Next Generation Driver and Front-Passenger Air Bag* System

Air Bag System Verification

After modification work is complete, the modifier must confirm air bag system readiness, as follows:

- Turn the ignition key on. The air bag lamp in the Instrument cluster will illuminate for six to eight seconds, and then turn off. If the air bag lamp fails to illuminate, cycles on and off, or does not turn off, the modifier must have the vehicle repaired by a Chrysler Motors LLC dealership before shipping.

Air Bag Diagnostic Module

The Air Bag Diagnostic Module is located under the floor console or 20% seat on the center tunnel between the seats, and is covered by a plastic trim cover. Care must be taken not to disturb this module for any reason. It is also important that no modifications are made to the tunnel sheet metal, as this may affect the performance of the air bag system.

Air Bag Wiring

All air bag wiring must remain intact and may not be used for any other purpose.

Location of Air Bag System Components

It is imperative that all air bag system components remain in their original location and orientation. Any removal or relocation of components, such as the diagnostic module or the instrument panel wiring, may be detrimental to air bag system performance and is prohibited.

Seatbelt

No modifications to the belt in terms of location or alteration to component is allowed for proper function.

Knee Blocker/Lower Steering Column Cover

The lower steering column cover area and glove box, also known as “knee blockers,” are integral parts of the air bag restraint system. These areas include energy-absorbing features and must not be removed or modified in any manner. This includes the attachment of any auxiliary switches, such as those for fog lamps or snowplow accessories.

Steering Column Collapse Zone

The steering column in this vehicle is designed to collapse axially under a compressive load in the event of a severe frontal impact. In order for the steering column to perform properly, it must not be modified in any manner. This includes all componentry, which is adjacent to the steering column, such as the shrouds, the upper support bracketry, and the toe board attachment. Caution must also be exercised to ensure that nothing is placed in the axial path of the steering column, or that any of the designed clearance gaps are disturbed.

Front Bumper System

Since the crash sensing of the air bag system is tuned, in part, to the front bumper, the original front bumper system (beam, brackets and fascia) of vehicles with a GVWR of 8,500 pounds or less, and an unloaded vehicle weight of 5,500 pounds or less, must be retained. No modifications or additions to the bumper (i.e., bumper-mounted bicycle racks) are permitted.

Warning Labels

Removing or covering air bag warning labels is prohibited. Labels (glove box, visors, etc.) are used to alert vehicle operators and service personnel that:



RAM OCCUPANT RESTRAINT SYSTEM INFORMATION

- The vehicle is equipped with an air bag, but always use seat belts and child restraints
 - A backseat is the safest place for children under 12
 - Never put a rearward-facing child seat in the front passenger seat unless the air bag is turned off
 - Caution must be exercised when the vehicle is serviced, since improper procedures may cause inadvertent air bag deployment
 - The system must be inspected at regular intervals, or when service is indicated by readiness lamp operation
 - If a sun visor is replaced, the replacement visor must be equipped with an equivalent warning label
4. The driver's side retractor must be connected to the Air Bag Electronic Control Module located under the driver's seat.

Miscellaneous Requirements

Any components added to the occupant compartment must not break loose during a 30-mph barrier impact test. A plot of the average passenger compartment deceleration with respect to time is shown in the pulse curve below.

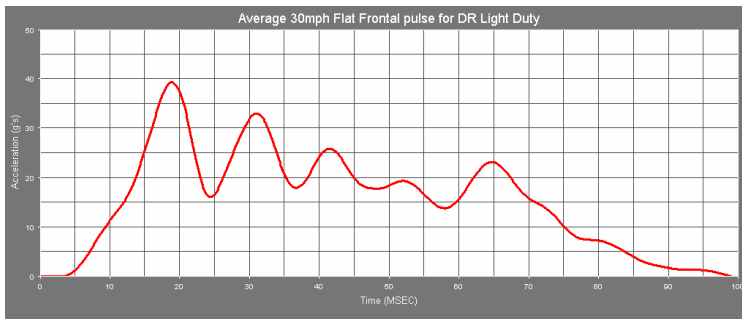

Further, any pulse curve information can be retrieved from the National Highway Traffic Safety Administration at the address below:

National Highway Traffic Safety Administration

Technical References Division
NAD-40, Room 5108
400 7th Street, S.W.
Washington, D.C. 20590
Telephone: (800) 445-0197
Working hours: 7:45 a.m. - 4:15 p.m. EST

- * Certified to the Federal Regulations that allow less forceful front air bags. Always use seat belts.

Upgraded Driver Restraint System

1. Disconnect battery negative terminal before removing the driver's side seat belt retractor.
2. The OEM driver's side retractor cover must be used unless approval is given from Chrysler LLC Modified Vehicles Engineering for an alternate retractor cover.
3. Store driver's side retractor in a secure area when removed from the vehicle to avoid damage or loss.



RAM OCCUPANT RESTRAINT SYSTEM INFORMATION

There are four interior zones to be aware of:

- Driver airbag deployment zone
- Passenger airbag deployment zone
- Side curtain airbags deployment zone
- Side airbags (seat-mounted) deployment zone

DRIVER AIRBAG DEPLOYMENT ZONE

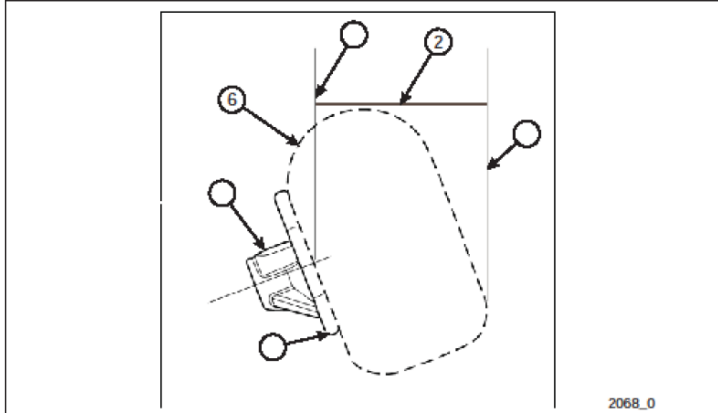

2068_0

1	Vertical Plane Passing Through the Center of the Steering Wheel	4	Steering Wheel
2	331mm (13")	5	Driver Airbag Retainer/Housing
3	Vertical Plane Passing Through the Maximum Rearward Point That the Driver Airbag Cushion Reaches	6	Driver Airbag Cushion

Figure 73 Driver Airbag Dimensions

NOTE: Illustration represents the maximum dynamic deployment shape.

Table 11 Driver Airbag Cushion Position

DAB diameter when full	661mm (26")
DAB depth when full	305mm (12")
Maximum rearward displacement during fill	407mm (16")

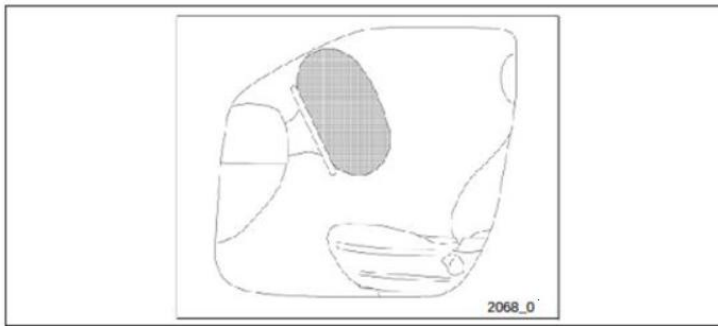
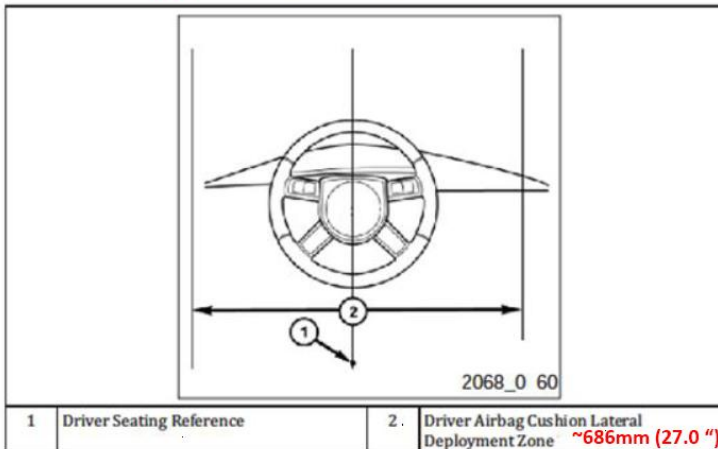

Figure 74 Driver Airbag Deployed Shape

Table 12 Steering Column Tilt Position Range

± 2 degrees from steering column tilt pivot point
$\sim 22.0^\circ$ degrees from vertical is the normal position



2068_0 60

1	Driver Seating Reference	2.	Driver Airbag Cushion Lateral Deployment Zone $\sim 686\text{mm}$ (27.0 ")
---	--------------------------	----	--

Figure 75 Deployment Zone



SIDE AIRBAG DEPLOYMENT ZONE

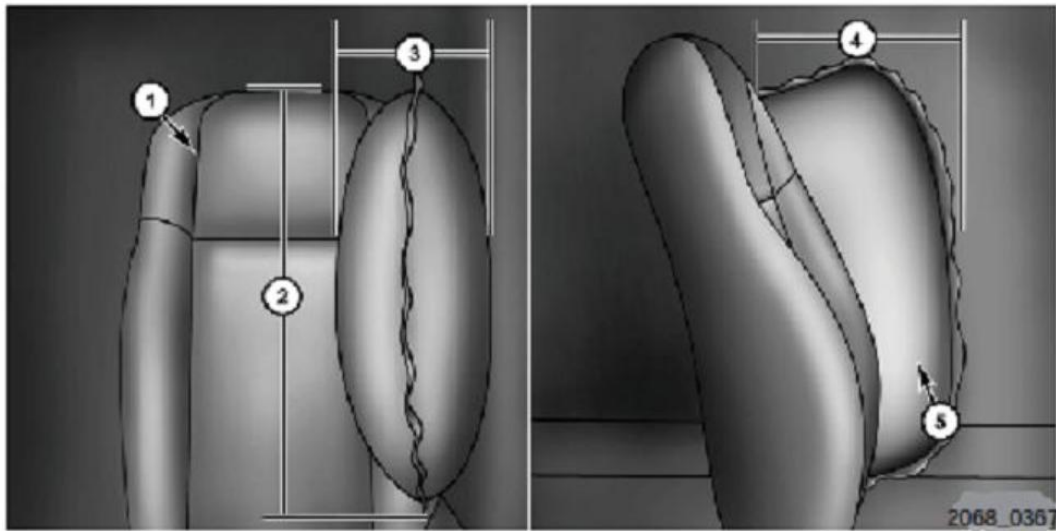

1	Front Driver Seat	4	270 mm (10.6")
2	460 mm (18.1")	5	Seat-mounted Airbag
3	130 mm (5.12")		

SIDE CURTAIN AIRBAG DEPLOYMENT ZONE

Crew

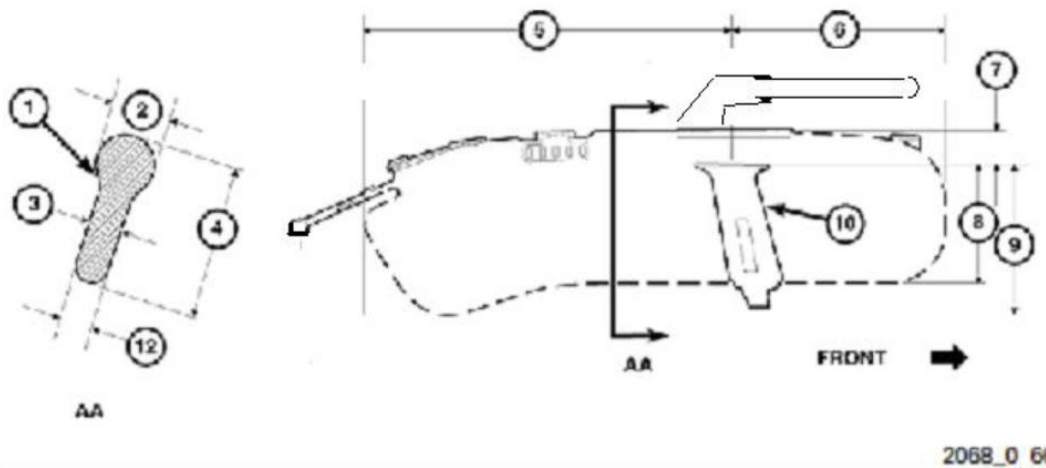

1	Cross Sectional Area Side View	7	80 mm (3.2")
2	120 mm (4.75")	8	508 mm (20")
3	120 mm (4.75")	9	508 mm (20")
4	508 mm (20")	10	B Pillar
5	560 mm (22.1")	11	Side Curtain Airbag Inflator Module
6	955 mm (37.6")	12	120 mm (4.75")

Figure 80 Side Curtain Airbag Deployment Zone



RAM OCCUPANT RESTRAINT SYSTEM INFORMATION

SIDE CURTAIN AIRBAG DEPLOYMENT ZONE Quad

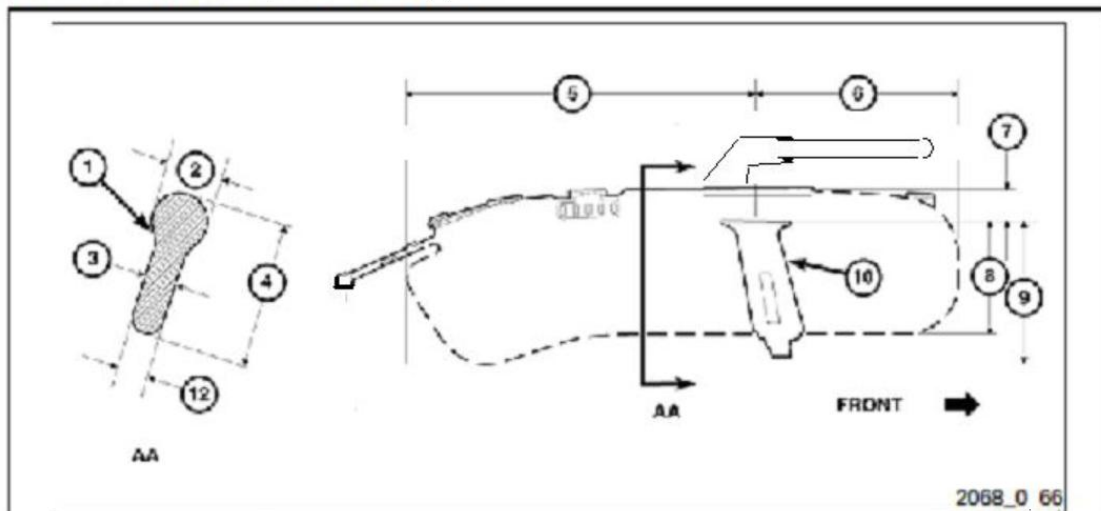

1	Cross Sectional Area Side View	7	80 mm
2	120 mm (4.75")	8	503 mm (19.8")
3	120 mm (4.75")	9	503 mm (19.8")
4	503 mm (19.8")	10	B Pillar
5	560 mm (22.1")	11	Side Curtain Airbag Inflator Module
6	766 mm (30.2")	12	120 mm (4.75")

Figure 80 Side Curtain Airbag Deployment Zone

SIDE CURTAIN AIRBAG DEPLOYMENT ZONE Mega

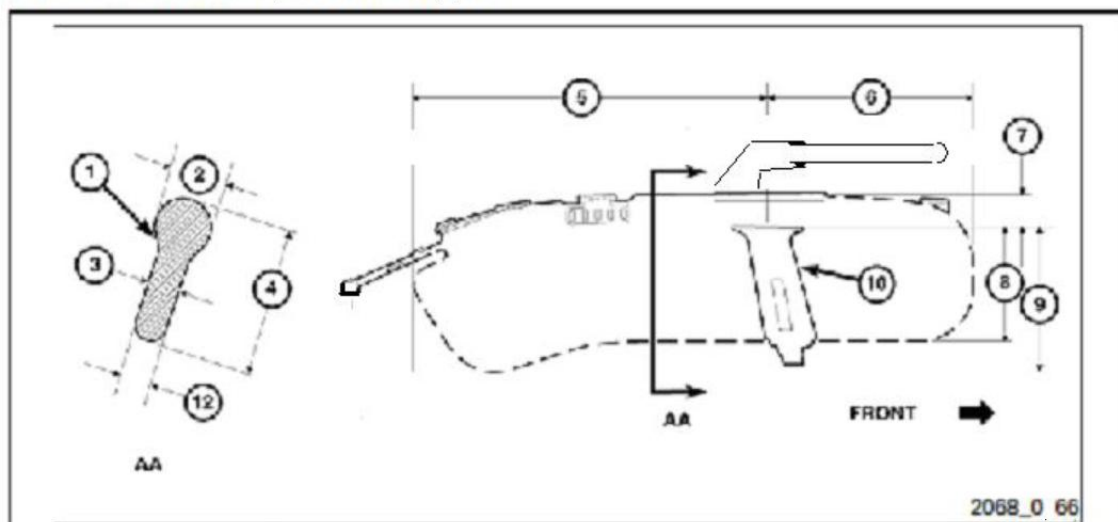

1	Cross Sectional Area Side View	7	80 mm (3.2")
2	120 mm (4.75")	8	512 mm (20.2")
3	120 mm (4.75")	9	512 mm (20.2")
4	512 mm (20.2")	10	B Pillar
5	560 mm (22.1")	11	Side Curtain Airbag Inflator Module
6	1097 mm (43.2")	12	120 mm (4.75")

Figure 80 Side Curtain Airbag Deployment Zone



SIDE CURTAIN AIRBAG DEPLOYMENT ZONE STD

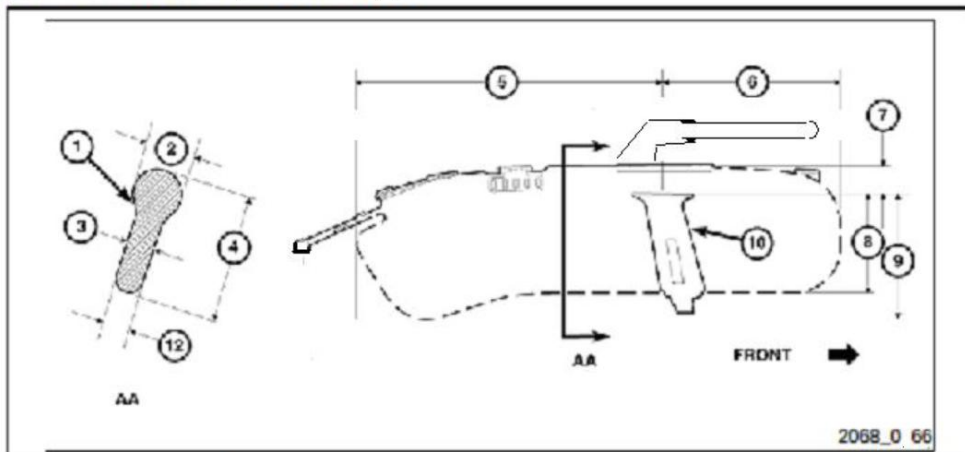

1	Cross Sectional Area Side View	7	80 mm (3.2")
2	120 mm (4.75")	8	504 mm (19.8")
3	120 mm (4.75")	9	504 mm (19.8")
4	504 mm (19.8")	10	B Pillar
5	696mm (27.4")	11	Side Curtain Airbag Inflator Module
6	0 mm	12	120 mm (4.75")

Figure 80 Side Curtain Airbag Deployment Zone

PASSENGER AIRBAG DEPLOYMENT ZONE

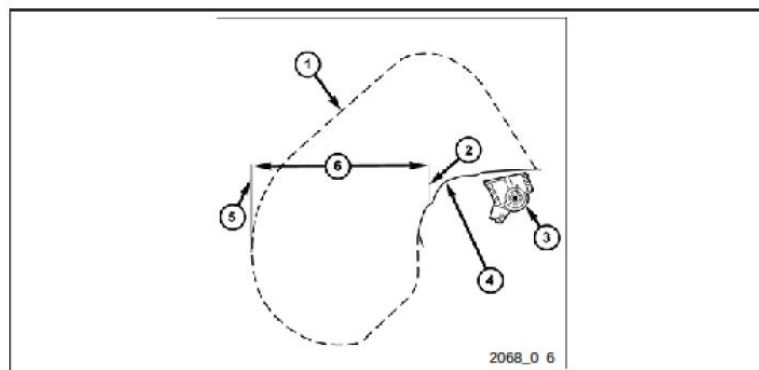

1	Passenger Airbag Cushion	4	Instrument Panel
2	Vertical Plane From Point of Instrument Panel	5	Vertical Plane Passing Through The Maximum Rearward Point That The Passenger Airbag Cushion Reaches
3	Passenger Airbag Module	6	675 (26.6")

Figure 76 Passenger Airbag Deployment Zone

NOTE: Illustration represents the maximum dynamic deployment shape.

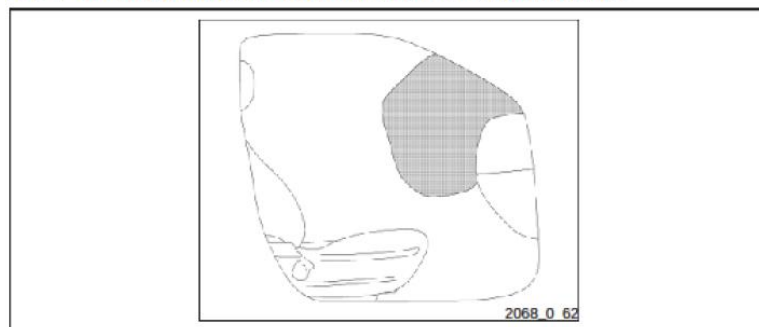

Figure 77 Final Deployment Shape



RAM OCCUPANT RESTRAINT SYSTEM INFORMATION

