

---

## CHASSIS CAB / PICKUP BACK UP CAMERA

### Overview

#### System Variations

The backup camera sales code is XAC. All ram back up camera systems use a common analog camera. Depending upon vehicle option content, the video monitor will either be in the radio or rear view mirror. If the vehicle has either a 5.0 inch or an 8.4 inch radio, the monitor will be in the radio. If the vehicle has the base 3.0 inch radio, the monitor will be in the rear view mirror. On pickup trucks with XAC the camera system will be completely functional from the factory. On chassis cabs with XAC, the vehicle electronics will be configured to operate properly once the camera is connected. Prior to connection, all monitors will display a blue screen when the vehicle is in reverse.

#### Chassis Cab

There are a number of electrical/wiring features at the rear of the Ram chassis. These features include the connector for the backup camera. Chassis cabs use a common wiring harnesses. So, this connector will be there whether the vehicle is equipped with sales code XAC or not.

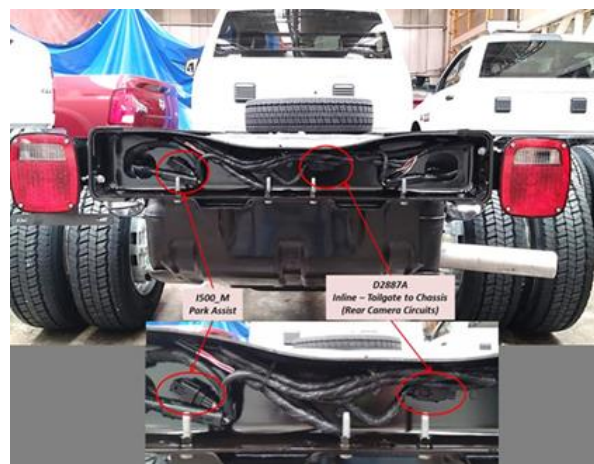

Chassis cabs equipped with XAC will have a camera kit shipped in cab of the vehicle. The kit consists of a user mountable camera (P/N 56038978AF) and a 10 foot cable (P/N 68200274AA) in a plastic bag.



A 30 foot cable (P/N 68239372AA) is also available for order through any Ram dealer.

---

## CHASSIS CAB / PICKUP BACK UP CAMERA

One end of the 10/30 foot cable plugs into the camera connector at the rear of the vehicle. It is a male plug located just to the right of center on the rear frame rail. The connector is secured in such a manner that they may be hidden by the harness bundle and may be difficult to see. Depending on the up fit being installed it may be easier to make this connection prior to installation of the up fit. The other end of the 10/30 foot cable plug into the camera.

#### Pickup With Factory Box Delete

On 2500/3500 pick-up trucks with factory box delete, (sales code XBC) the backup camera system consists of the same hardware and electrical/electronic connections and configurations as the chassis cab.

#### Pickup Box/Tailgate Removal

On 2500/3500 pick-up trucks where the box and/or tailgate are removed in the field, the tailgate connector at the rear valance will get unplugged, disconnecting the camera from the system. This will cause the camera display to display a blue screen when the vehicle is in reverse. MOPAR has developed an adaptor pigtail that will adapt the tailgate connector of the pick-up's chassis harness to either the 10 or 30 foot chassis cab cables described in the paragraphs above. The adaptor part number is 82215671AB and is available at any Ram dealer. The camera can be removed from the tailgate and used with the 10 or 30 foot cable or a new camera can be purchased through a dealer.



**PICKUP CAMERA ADAPTOR  
MOPAR PART NUMBER 82215671AB**

#### **FMVSS111**

Changes to FMVSS111 require a backup camera on all vehicles with a GVWR of less than 10,000 lbs. Starting May 1<sup>st</sup> 2018, up fitters must insure that vehicles model year 2018 and newer and have a GVWR of less than 10,000 lbs. meet FMVSS111.

For model years 2018 and beyond, ALL pick-ups, including 3500 pick-up, will have a standard back up camera. Also for model year 2018, back up camera is standard on chassis cabs with a GVWR of less than 10,000 lbs. (DF model 3500) Back up camera is an option on all chassis cabs with a GVWR of 10,000 lbs. and greater. This includes DD (3500) and DP (4500 and 5500) models.

---

#### **CHASSIS CAB / PICKUP BACK UP CAMERA**

FMVSS111 has certain system function requirements as well as image size and field of view requirements. If you are up fitting a vehicle with a GVWR of less than 10,000 lbs. you will need to familiarize yourself with those requirements. The camera system as shipped will meet the system function requirements. However, field of view and image size are effected by camera location. You will need to select a camera location that allows the system to meet these requirements.

The NTEA has developed a test method and provided educational resources to help members understand FMVSS111 and verify that the system meets image size and field of view requirements. We recommend that you use the NTEA method to determine an appropriate camera location and angles.



NTEA members can purchase the kit through the NTEA web site.

<http://www.ntea.com/StoreCategory?Cat=PUBSGUIDES>

See items titled FMVSS 111 FIELD OF VIEW (REARVIEW CAMERA) CONFORMITY MANUAL (# 2296) or FMVSS 111 FIELD OF VIEW CONFORMITY MANUAL AND KIT. (# 2297)

---

### CHASSIS CAB / PICKUP BACK UP CAMERA

---

## Camera Mounting

### General

Unless the up fit has been designed with a feature to mount the camera, a bracket will need to be fabricated. If practical, it is desirable to mount the camera in a location where the connector on the rear of the camera can be inside the up fit and shielded from the outside environment. If fabricating a bracket, it should be designed to offer as much protection to the camera and connector as possible. A mechanical layout of the camera is in **Appendix A**.

### Placement

**ATTENTION:** *The camera placement zone shown below is intended to assist the upfitter in meeting the requirements of FMVSS111. Compliance to FMVSS111 will be the responsibility of the final stage manufacturer who certifies the vehicle.*

**NOTE:** This information is provided for directional purposes only, based on testing performed by FCA US LLC.

The recommended camera placement zone is defined in Figures 1 and 2. The diamond in the center of the green zone is the optimum placement location. Lateral dimensions are from the centerline of the vehicle and vertical dimensions are to the ground plain. **Figure 1** is for the recommended camera mounting location for the rear view mirror display and **Figure 2** is the recommended camera mounting location for the 5.0 and 8.4 inch radio displays.

If the camera is mounted somewhere within the specified zone, the system is capable of meeting FMVSS111. Depending upon the up fit, it may be possible to meet FMVSS111 with the camera mounted in areas outside of the recommended zone. However gaining compliance may be difficult and may require more development work.

**Figure 1**

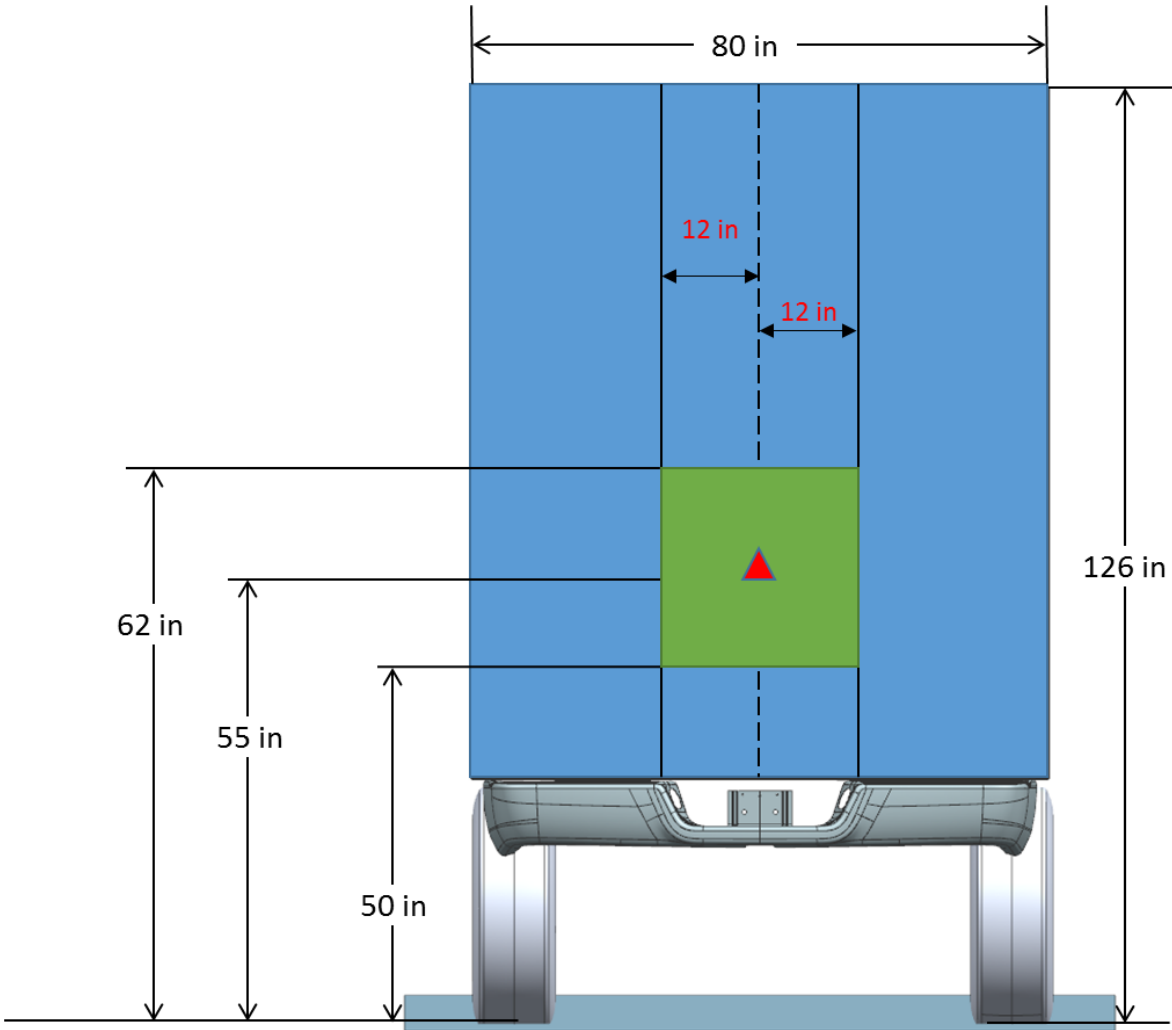

**CAMERA MOUNTING LOCATION WITH REAR VIEW MIRROR DISPLAY**

**CHASSIS CAB / PICKUP BACK UP CAMERA**

Figure 2

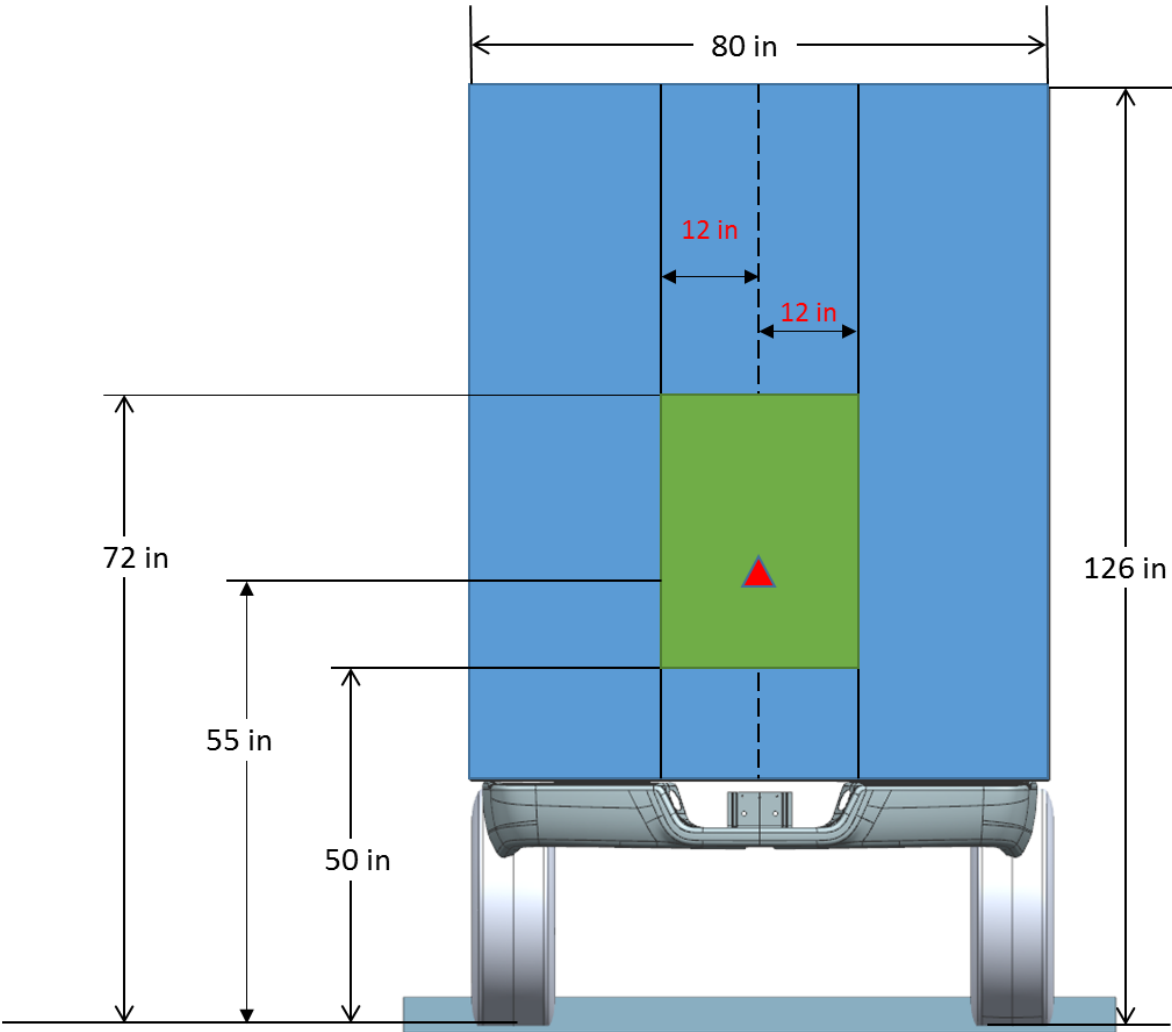

CAMERA MOUNTING LOCATION WITH 5.0 OR 8.4 INCH RADIO DISPLAY

CHASSIS CAB / PICKUP BACK UP CAMERA

---

## Aim

The camera should be mounted so the lateral (cross vehicle) centerline of the camera is parallel to the lateral (cross vehicle) centerline of the vehicle. In other words, the camera aimed straight rearward, not left or right.

The vertical aim or “look down angle” will be selected to achieve FMVSS111 compliance.

## Look Down Angle Determination

The NTEA FMVSS 111 field of view conformity manual and kit (NTEA # 2297) should be used to determine the appropriate look down angle to meet FMVSS111 field of view and image size requirements.

**ATTENTION:** When the vehicle is first placed in reverse, there will be a warning message at the top of the screen for the first 5 seconds. **THAT WARNING MESSAGE CANNOT INTERFERE WITH THE TEST OBJECTS.** If it does, you may need to adjust the look down angle upward slightly to compensate. Examples of images to demonstrating message interference are in Appendix B Please note these are SIMULATED images.

**Appendix A**

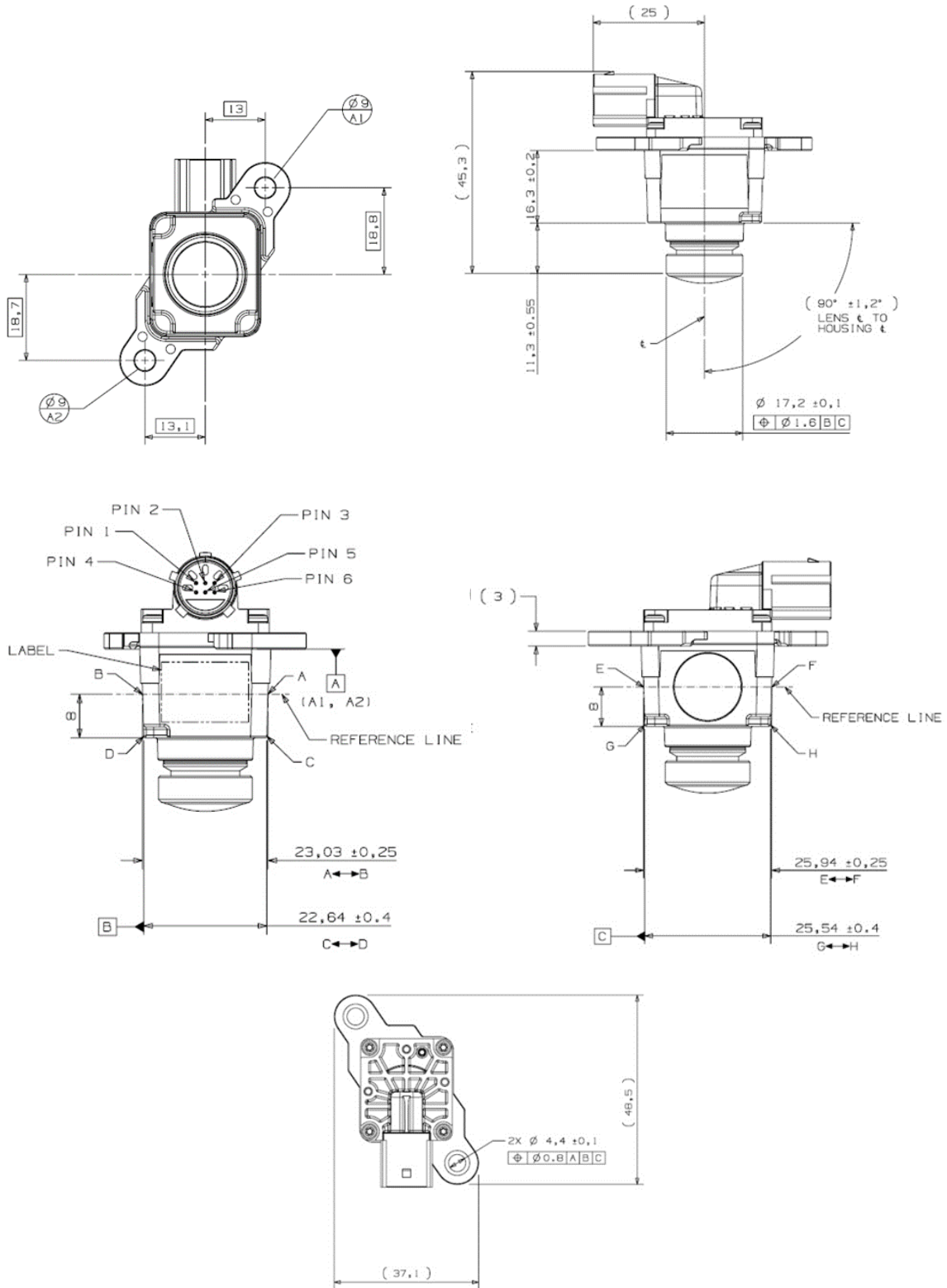

**CHASSIS CAB / PICKUP BACK UP CAMERA**

---

### Appendix B

In the following image, the system does not meet FMVSS11 requirements with the warning message displayed. The message covers the top of the rear cones and the black stripes are obscured.



In the following image, the system does meet FMVSS11 requirements with the warning message displayed. The message is well above the top of the rear cones and the black stripes are completely visible.

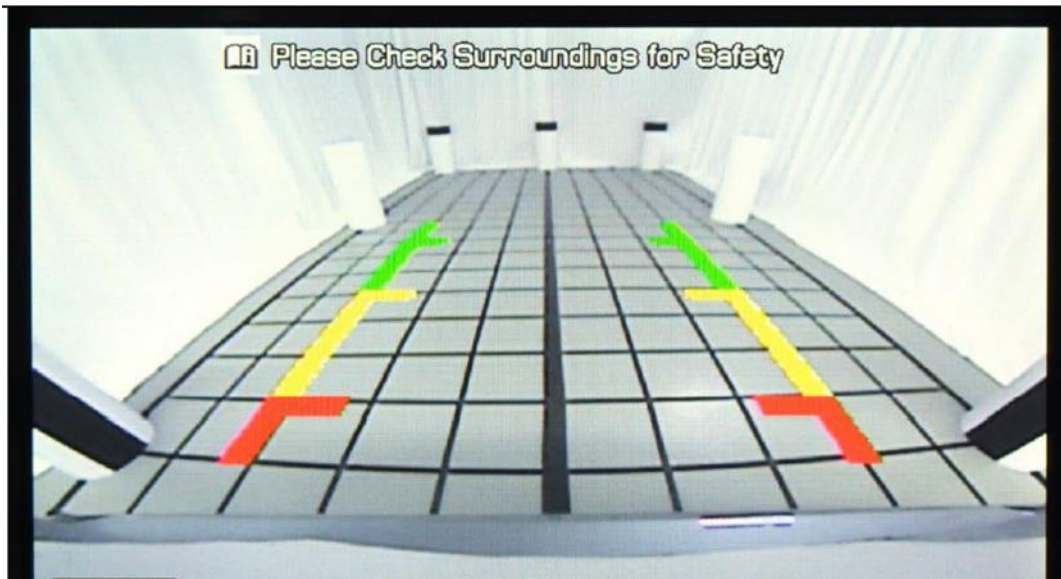

---

### CHASSIS CAB / PICKUP BACK UP CAMERA