

68550222AA

FCA US LLC

800 CHRYSLER DRIVE
AUBURN HILLS, MI 48326-2757

CAUTION: TRANSPORTATION AND DEALER PERSONNEL - THIS DOCUMENT TO BE REMOVED FROM THE VEHICLE BY THE FINAL STAGE MANUFACTURER ONLY

INCOMPLETE VEHICLE DOCUMENT

2022 PICKUPS AND CHASSIS CABS

THIS DOCUMENT APPLIES TO RAM HEAVY DUTY TRUCK MODELS DJ/D2 (2500/3500 4X2 AND 4X4) WITH FACTORY BOX OFF OPTION, AND ALL CHASSIS CAB TRUCK MODELS DF - DD/ DP (3500/4500-5500 4X2 AND 4X4)

The purpose of this document is to provide information and direction to subsequent manufacturers who must certify compliance of vehicles manufactured in two or more stages with the United States Federal Motor Vehicle Safety Standards (FMVSS) and the Canada Motor Vehicle Safety Standards (CMVSS), and other regulations applicable to the USA and/ or Canada.

This document is provided in accordance with 49 CFR Part 568 - Vehicles Manufactured in Two or More Stages (National Highway Traffic Safety Administration), and Canada Motor Vehicle Safety Standards, Section 6.1, Vehicles Manufactured in Stages (Transport Canada).

The statements contained in this Incomplete Vehicle Document are accurate as of the date of manufacture of the Incomplete Vehicle and can be relied on by any intermediate and/ or final stage manufacturer as a basis for certification.

**AFFIX FEDERAL OR CANADA INCOMPLETE
VEHICLE CERTIFICATION LABEL HERE**

Upon completion of this vehicle, the final-stage upfitter, alterer, or manufacturer must place a completed Vehicle Tire and Loading Placard on driver's side B-Pillar of the vehicle, as required by FMVSS/ CMVSS 110. The sticker below shows the information you will need for the Vehicle Placard.

AFFIX TIRE LOAD LABEL HERE

Unique Canadian Requirements

This Incomplete Vehicle as produced by FCA US LLC conforms in full with the Canadian Motor Vehicle Safety Regulations indicated by (†) in the listing throughout this document except as noted for CMVSS 108 and 111. In addition, this incomplete vehicle also conforms to Canadian Motor Vehicle Safety Regulation (CMVSS) 1106 - Interior and Exterior Noise, and, when completed, will continue to comply if no alterations are made to the air intake system, cooling system, exhaust system or tires, and no obstructions are placed in close proximity with the tail pipe outlet. Further, this incomplete vehicle, as manufactured by FCA US LLC, fully complied with Interference-Causing Equipment Standard ICES-002, and when completed will continue to comply if no alterations are made to the distributor, ignition coils, ignition wires, spark plug wires, spark plugs or spark plug sleeves.

Please consult the Body Builder's Guide at Ramtrucks.com for further information

The following safety standards information is valid only if this vehicle is completed as one of the following types: Truck, Motorhome, or Multipurpose Passenger Vehicle (MPV).

No representation as to conformity to any FMVSS or CMVSS beyond the information specifically contained within this document is made.

Ram Models DJ/D2 (2500, 3500 4x2 & 4x4) with factory box off option, and DF-DD/DP (3500/ 4500-5500 4x2 & 4x4) Chassis Cab.

<p>FMVSS 101 CMVSS 101 †</p>	<p>This vehicle, when completed, will conform to <u>FMVSS 101: Controls and Displays</u> if no alterations are made to the location, visibility, identification or illumination of the controls covered by this standard, including the driver's seating position. Subsequent manufacturer(s) must assure compliance for any controls which are added and covered by this standard.</p>
<p>FMVSS 102 CMVSS 102 †</p>	<p>This vehicle, when completed, will conform to <u>FMVSS 102: Transmission Shift Position Sequence, Starter Interlock, and Transmission Braking Effect</u> if no alterations are made to the transmission, shift control, accelerator control, or starter interlock system on automatic transmissions, provided that the shift lever positions are permanently displayed in view of the driver.</p>
<p>FMVSS 103 CMVSS 103 †</p>	<p>This vehicle, when completed, will conform to <u>FMVSS 103: Windshield Defrosting and Defogging Systems</u> if no alterations are made to the defroster system, including vehicle heater assembly and controls.</p>
<p>FMVSS 104 CMVSS 104 †</p>	<p>This vehicle, when completed, will conform to <u>FMVSS 104: Windshield Wiping and Washing Systems</u> if no alterations are made to the windshield wiping or washing system.</p>
<p>FMVSS 105 CMVSS 105 †</p>	<p>This vehicle, when completed, will comply with <u>FMVSS 105 - Hydraulic Brake Systems</u> if:</p> <ul style="list-style-type: none"> • No alterations are made to the service and parking brake systems • Rear axle must carry at least 37 percent of the vehicle weight when the front seat is ballasted as follows: <u>GVWR Front Seat Ballast</u> <10,000 lb (4,536 kg) 400 lb >10,000 lb (4,536 kg) 500 lb • The GVWR and GAWR are not exceeded. • The height above the frame rail datum, top of frame rail (at rear axle), to ground line of the combined centers of gravity of components added by the subsequent manufacturer (Y), does not exceed Ymax <p><u>For the Ram Pickup and 3500 Chassis Cab</u> Ymax = B - 1.6(X)</p> <p><u>For the 4500 and 5500 Chassis Cab</u> Ymax = B - .9(X)</p> <p>NOTE: If the combined CG of the added components is behind the rear axle, then Ymax = B + [1.6x or .9x] X = horizontal distance in inches from the centerline of the rear axle to the combined center of gravity of all the added items MINUS (-) is forward and PLUS (+) is rearward of rear axle centerline. B = factors (see chart at end of document).</p> <p>NOTE: FMVSS 105 is applicable only if completed vehicle has a GVWR of 7,716 lbs (3,500 kg) or more.</p>
<p>FMVSS 106 CMVSS 106 †</p>	<p>This vehicle, when completed, will conform to <u>FMVSS 106: Brake Hoses</u> if no alterations are made to the hydraulic or vacuum brake hose assemblies.</p>
<p>FMVSS 108 CMVSS 108 †</p>	<p>This vehicle, as shipped, may NOT conform to <u>FMVSS 108: Lamps, Reflective Devices and Associated Equipment</u> in its present (incomplete) stage of manufacture. It is the responsibility of the Final Stage Manufacturer to ensure compliance.</p>
<p>FMVSS 110 CMVSS 110 †</p>	<p>This vehicle as shipped does NOT conform to <u>FMVSS 110: Tire Selection and Rims and Motor Home / Recreation Vehicle Trailer Load Carrying Capacity Information for Motor Vehicles with GVWR of 4,536 kg (10,000 pounds) or Less</u>. It is the responsibility of the Final Stage Manufacturer to properly affix the Tire and Loading placard label to the vehicle according to FMVSS 110, as well as assure tire, tire rims and tire pressure are appropriately selected for the vehicle.</p>
<p>FMVSS 111 CMVSS 111 †</p>	<p>This vehicle, as shipped, does NOT conform to <u>FMVSS 111: Rear Visibility</u> due to the rear camera being shipped loose. It is the upfitter/ final stage manufacturer's responsibility to ensure that the camera, as provided, is mounted in such a way that it meets all requirements of FMVSS 111 - Rear Visibility.</p>
<p>FMVSS 113 CMVSS 113 †</p>	<p>This vehicle, when completed, will conform to <u>FMVSS 113: Hood Latch Systems</u> if no alterations are made to the hood latches or attaching parts.</p>
<p>FMVSS 114 CMVSS 114 †</p>	<p>This vehicle, when completed, will comply with <u>FMVSS 114: Theft protection and Rollaway Prevention</u> if no alterations are made to the steering column lock, transmission shift linkage, the ignition switch interlock, the audible key-left-in-lock warning system, or the electronic engine immobilizer system. Completed vehicles with a GVWR of 10,000 lbs (4,536 kg) or less are required to be equipped with an electronic engine immobilizer system (CANADA). NOTE: FMVSS 114 is applicable only if completed vehicle has GVWR of 10,000 lbs (4,536 kg) or less.</p>
<p>49 CFR Part 565 CMVSS 115 †</p>	<p>This vehicle, when completed, will conform to <u>49 CFR Part 565 - Vehicle Identification Number (VIN) Requirements</u> or <u>CMVSR 115: Vehicle Identification Number</u> if:</p> <ul style="list-style-type: none"> • No alterations are made to the VIN plate, VIN plate-mounting, or the VIN plate location • No component installed by the subsequent manufacturer(s) obscures the visibility of the VIN plate through the windshield.
<p>FMVSS 116 CMVSS 116 †</p>	<p>This vehicle, when completed, will conform to <u>FMVSS 116: Motor Vehicle Brake Fluids</u> if no alterations, substitutions, or introduction of foreign material are made to the brake fluid.</p>
<p>FMVSS 118 CMVSS 118 †</p>	<p>This vehicle, when completed, will conform to <u>FMVSS 118: Power-Operated Window, Partition and Roof Panel Systems</u> if no alterations are made to the power window and related electrical systems. Subsequent manufacturer(s) must assure compliance with <u>FMVSS 118: Power-Operated Window, Partition and Roof Panel Systems</u> if powered roof panels, internal partitions or power operated rear window systems are installed. NOTE: FMVSS 118 is applicable only if completed vehicle has GVWR of 10,000 lbs (4,536 kg) or less.</p>

FMVSS 119 CMVSS 119 †	<p>This vehicle, when completed, will conform to <u>FMVSS 119: New Pneumatic Tires for Motor Vehicles other than Passenger Cars</u> if:</p> <ul style="list-style-type: none"> • No tire alterations or substitutions are made • The required tire data are either added to the vehicle's certification label or furnished on a separate tire information label • The tire load carrying capacity and speed rating are not exceeded <p>NOTE: FMVSS 119 is applicable only if completed vehicle has a GVWR of more than 10,000 lbs (4,536 kg)</p>
FMVSS 120 CMVSS 120 †	<p>This vehicle, as shipped, does NOT conform to FMVSS 12 - Tire Selection and Rims for Motor Vehicles with a GVWR of more than 10,000 lbs (4,536 kg). It is the responsibility of the final stage manufacturer to ensure the following conditions are met to allow compliance:</p> <ul style="list-style-type: none"> • No alterations are made to the tires and rims • The required tire and rim data are either added to the completed vehicle's certification label or furnished on a separate tire information label or furnished on a separate tire information label in accordance with FMVSS 110. Section 4 (for vehicles of GVWR < 10,000 lbs (4,536 kg)) and FMVSS 120 (for vehicles with a GVWR > 10,000 lbs (4,536 kg)) • The load carrying capacity and speed rating of the required tires and wheels are not exceeded • Tire Loading label is incomplete on IVD vehicles and must be printed by Final Vehicle Manufacturer
FMVSS 124 CMVSS 124 †	<p>This vehicle, when completed, will conform to <u>FMVSS 124: Accelerator Control Systems</u> if no alterations are made to the accelerator control system.</p>
FMVSS 126 CMVSS 126 †	<p>This vehicle, when completed, will conform to <u>FMVSS 126: Electronic Stability Control Systems</u> if no alterations are made to the stability control system or related chassis and/ or electrical components.</p> <p>NOTE: FMVSS 126 is applicable only if completed vehicle has a GVWR of 10,000 lbs (5,436 kg) or less.</p>
FMVSS 138	<p>This vehicle, when completed, will conform to <u>FMVSS 138: Tire Pressure Monitoring Systems</u> if no alterations are made to the tire pressure monitoring system or related chassis and/ or electrical components.</p> <p>NOTE: FMVSS 138 is applicable only if completed vehicle has a GVWR of 10,000 lbs (4,536 kg) or less.</p>
FMVSS 139 CMVSS 139 †	<p>This vehicle, when completed, will conform to <u>FMVSS 139 - New Pneumatic Radial Tires for Light Vehicles</u> if no alterations are made to the radial tires or related chassis components.</p> <p>NOTE: FMVSS 139 is applicable only if completed vehicle has a GVWR of 10,000 lbs (4,536 kg) or less.</p>
FMVSS 201 CMVSS 201 †	<p>This vehicle, when completed, will conform to <u>FMVSS 201: Occupant Protection in Interior Impact</u> if no alterations are made to the seat locations, front windshield size/ location, instrument panel, armrests, the interior trim including but not limited to, the upper interior trim including that over the doors, windshield and rear window, the roof side rails, the headliner, headliner and roof mounted components, and the roof pillars.</p> <p>NOTE: FMVSS 201 is applicable only if completed vehicle has a GVWR of 10,000 lbs (4,536 kg) or less.</p>
FMVSS 202 FMVSS 202a CMVSS 202 †	<p>This vehicle, when completed, will conform to <u>FMVSS 202a: Head Restraints</u> if no alterations are made to the seats or head restraints.</p> <p>NOTE: FMVSS 202a is applicable only if completed vehicle has a GVWR of 10,000 lbs (4,536 kg) or less.</p>
FMVSS 203 CMVSS 203 †	<p>This vehicle, when completed, will conform to the applicable sections of <u>FMVSS 203: Impact Protection for the Driver from the Steering Control System</u> if no alterations are made to the driver's seat location, steering wheel, steering column assembly or any attaching parts.</p> <p>NOTE: FMVSS 203 is applicable only if completed vehicle has a GVWR of 10,000 lbs (4,536 kg) or less.</p>
FMVSS 204a CMVSS 204 †	<p>This vehicle, when completed, will conform to <u>FMVSS 204: Steering Control Rearward Displacement</u> if</p> <ul style="list-style-type: none"> • No alterations are made to the steering control system, including, but not limited to, steering wheel, steering column assembly, front structure, bumper and attaching parts. • When tested in accordance with the requirements of the standard; (1) no component installed by the subsequent manufacturer impinges upon the steering control system with the sufficient energy to displace the steering control systems, and (2) no vehicle modification by the subsequent manufacturer results in any portion of the vehicle impinging upon the steering control system with sufficient energy to displace the steering control system. <p>NOTE: FMVSS 204 is applicable only if completed vehicle has: (1) a GVWR of 10,000 lbs (4,536 kg) or less and (2) an unloaded vehicle weight of 5,500 lbs (2,495 kg) or less.</p>
FMVSS 205 CMVSS 205 †	<p>This vehicle, when completed, will conform to <u>FMVSS 205: Glazing Materials</u> if no alterations are made to the windshield or windows, and if no nonconforming glazing materials are added.</p>
FMVSS 206 CMVSS 206 †	<p>This vehicle, when completed, will conform to <u>FMVSS 206: Door Locks and Door Retention Components</u> if no alterations are made to the door locks, door latches, door hinges or their attachments.</p> <p>NOTE: If any doors are added it is the responsibility of the upfitter to ensure adherence to FMVSS 206</p> <p>NOTE: Applies to vehicles completed as buses and < 10,000 lbs GVWR. Applies to all other vehicles regardless of GVW.</p>
FMVSS 207 CMVSS 207 †	<p>This vehicle, when completed, it will conform to <u>FMVSS 207: Seating Systems</u> if no alterations are made to the seats, seat tracks, vehicle underbody including, but not limited to frame, body, body mounts, or any attaching parts. Subsequent manufacturers must assure compliance for any added designated seating positions and for any modifications that may alter the crash characteristics, performance, or pulse, including, but not limited to, crash sensors and airbag deployment electronics, occupant restraint system including the seat belt system and airbags.</p>
FMVSS 208 CMVSS 208 †	<p>This vehicle, when completed, will conform to <u>FMVSS 208: Occupant Crash Protection</u> if no alterations are made to the seat belts and seat belt warning system, airbags and airbag warning system, seat locations and/ or the windshield header. Subsequent manufacturer(s) must assure compliance for any added designated seating positions and for any modifications to the vehicle front end structure that may alter the crash characteristics, performance, or pulse, including, but not limited to, crash sensors and airbag deployment electronics, occupant restraint system including the seat belt system and airbags, steering system and knee blockers.</p>
FMVSS 209 CMVSS 209 †	<p>This vehicle, when completed, will conform to <u>FMVSS 209: Seat Belt Assemblies</u> if no alterations are made to the seat belt assemblies. Subsequent manufacturers must assure compliance for added designated seating positions.</p>

FMVSS 210 CMVSS 210 †	This vehicle, when completed, will conform to <u>MVSS 210; Seat Belt Assembly Anchorages</u> if no alterations are made to the seat belt assembly anchorages, body parts, frame, body mounts, or seat location. Subsequent manufacturer(s) must assure compliance for any added designated seating positions.
FMVSS 212 CMVSS 212 †	This vehicle, when completed, will conform to <u>MVSS 212; Windshield Mounting</u> if: <ul style="list-style-type: none"> No alterations are made to the body, body mounts, and frame rails that significantly affect crush from back of the cab forward in the vehicle. No alterations are made to the windshield or the windshield mounting system, When tested in accordance with the requirements of this standard: (1), no component installed by the subsequent manufacturer(s) impinges upon the vehicle with sufficient energy to separate the windshield from its mounting, and (2), no vehicle modification by the subsequent manufacturer(s) results in any portion of the vehicle impinging upon the front of the vehicle with sufficient energy to separate the windshield from its mounting. NOTE: MVSS 212 is applicable only if completed vehicle has a GVWR of 10,000 lbs (4,536 kg) or less.
FMVSS 214 CMVSS 214 †	This vehicle, when completed, will conform to the door crush resistance requirements of <u>MVSS 214; Side Impact Protection</u> if no alterations are made to the vehicle, including but not limited to the seat belt and seat belt warning systems, seat locations, headliner assembly, doors, door frames, door latches, door hinges or attaching parts, vehicle structure below the doors and the door aperture structure. Subsequent manufacturer(s) must assure compliance for any added designated seating positions and for any modifications that may alter the crash characteristics, performance, or pulse, including, but not limited to, crash sensors and airbag deployment electronics, occupant restraint system including the seat belt system and airbags. NOTE: MVSS 214 is applicable only if completed vehicle has a GVWR of 10,000 lbs (4,536 kg) or less.
FMVSS 216 CMVSS 216 †	This vehicle, when completed, will conform to <u>MVSS 216; Roof Crush Resistance</u> , if no alterations are made to the roof panel or its support structure, including the roof rails, front header, roof pillars, the door window frames, the windshield and the windshield mounting system. NOTE: MVSS 216a is applicable only if completed vehicle has a GVWR of 10,000 lbs (4,536 kg) or less.
FMVSS 219 CMVSS 219 †	This vehicle, when completed, will conform to <u>MVSS 219; Windshield Zone Intrusion</u> if: <ul style="list-style-type: none"> No alterations are made to the hood mounting system, the body & vehicle structure that would alter vehicle crush from just behind the front seats forward in the vehicle. When tested in accordance with the requirements of this standard: (1), no component installed by the subsequent manufacturer(s) penetrates the "protected zone" of the windshield or the inner surface of that portion of the windshield below the "protected zone" and (2), no vehicle modification by the subsequent manufacturer results in any portion of the vehicle penetrating the "protected zone" of the windshield or the inner surface of that portion of the windshield below the "protected zone". NOTE: MVSS 219 is applicable only if completed vehicle has a GVWR of 10,000 lbs (4,536 kg) or less.
FMVSS 225 CMVSS 210.1 † CMVSS 210.2 †	This vehicle, when completed, will conform to <u>FMVSS 225 Child Restraint Anchorage Systems (USA)</u> , <u>CMVSS 210.1 and 210.2 Tether Anchorages for Restraint</u> if no alterations are made to child seat top anchorages, body parts or seat locations. Subsequent manufacturer(s) must assume compliance for added designated seating positions.
FMVSS 226 CMVSS 226 †	This vehicle, when completed, will conform to <u>FMVSS 226; Ejection Mitigation</u> if no alterations are made to the seat belt, seat locations, roof rail, A-pillar/B-pillar upper, and/or windshield header. Subsequent manufacturer(s) must assure compliance for any modifications to the vehicle side structure that may alter the crash characteristics, performance, or pulse, including, but not limited to rails or attaching parts, crash sensors and side airbag curtain deployment electronics. NOTE: MVSS 226 is applicable only if completed vehicle has a GVWR of 10,000 lbs (4,536 kg) or less.
FMVSS 301 CMVSS 301 †	This vehicle, when completed, will conform to <u>MVSS 301; Fuel System Integrity</u> if: <ul style="list-style-type: none"> No alterations are made to the fuel system. The subsequent manufacturer completes the frame mounted fuel filler pipe installation according to the instructions provided in the fuel filler kit The <u>Unloaded Vehicle Weight (UVW)</u> of the completed vehicle does not exceed the values listed in the next table When tested in accordance with the requirements of this standard, no component installed by the subsequent manufacturer impinges upon the fuel system with sufficient energy to puncture or separate the fuel system, and no vehicle modification by the subsequent manufacturer results in any portion of the vehicle impinging upon the fuel system with sufficient energy to puncture or separate the fuel system. NOTE: vehicle will meet MVSS 301 if upfitter installs the fuel filler neck per instructions provided in Ram Body Builders Guide (BBG) NOTE: MVSS 301 is applicable only if completed vehicle has a GVWR of 10,000 lbs (4,536 kg) or less.

RAM MODEL ≤ 10,000 lbs (4,536 kg) GVWR MAX UNLOADED VEHICLE WEIGHT (UVW)

Rr Axle Wheel Config	Ram Model/ Code	Engine	Body	WB	GVWR (lbs)		UVW
					4x2	4x4	
Single Rear Wheel	2500 Pickup (DJ)	6.4L V8	Reg	140.5	10,000/ 9,900*		8,000
			Crew	149.4			
				169.4			
	3500 Chassis Cab (DF)	6.4L V8	Reg	143.5	10,000*	10,000*	8,000
Crew			172.5				

*option

FMVSS 302 CMVSS 302 †	This vehicle, when completed, will conform to <u>FMVSS 302: Flammability of Interior Materials</u> if the subsequent manufacturer(s) make no alterations to any interior component and no non-conforming interior materials are added.
49 CFR Part 393 CMVSR Part 393 (Sect 6-6.6)	This vehicle, when completed will conform to 49 CFR Part 393 - Parts and Accessories Necessary for Safe (Sect 6-6.6) Operation if no alterations are made to the following: <ul style="list-style-type: none"> ● Brakes (Part 393, Subpart C) ● Glazing (Part 393, Subpart D) ● Heating Systems (Part 393.77) ● Horn (Part 393.81) ● Speedometer (Part 393.82) ● Exhaust System (Part 3.39.83) ● Floors (Part 393.84) ● Interior Noise (Part 393.94) Subsequent manufacturers must assure compliance to the following: Lighting Devices, Reflectors and Electrical Equipment (Part 393, Subpart B) NOTE: *49 CFR Part 393 is applicable only if completed vehicle has a GVWR of 10,000 lbs (4,536 kg) or more.

Other Federal Requirements

Exterior Noise - Ram 3500, 4500, and 5500 4x2 and 4x4 models with a GVWR of more than 10,000 lbs (4,536 kg) only

This incomplete vehicle, as manufactured by FCA US LLC fully complied with the Environmental Protection Agency's Exterior Noise Regulations - 40 CFR Part 205. When completed, it will continue to comply if no alterations are made to the air intake system, cooling system, exhaust system or tires, and no obstructions are placed in close proximity to the tail pipe outlet.

Note: Intermediate Manufacturer(s)

Each intermediate manufacturer making any changes in this vehicle which affect the validity of any statement in this document as provided to him must furnish an addendum to this document that contains his name, mailing address and an indication of all changes that should be made in this document to reflect changes that he made in this vehicle. The incomplete vehicle manufacturer must then furnish this document, along with any addenda, as required, and in the manner specified in Paragraph 568.5 of Part 568 Title 49 CFR Part 568.

Note: Final Manufacturer

The final-stage manufacturer must complete this vehicle in such a manner that it conforms to all standards in effect on the date of manufacture by FCA US LLC, the date of final completion, or a date between those dates. The final-stage manufacturer must certify the completed vehicle as required by Paragraphs 567.5 and 568.6 of Title 49 CFR Part 567 and 568 respectively. The final-stage manufacturer must complete the vehicle in such a manner that during its intended usage, the vehicle does not exceed front and rear gross axle weight ratings (GAWR), and the vehicle does not exceed the gross vehicle weight rating (GVWR) as specified on the incomplete vehicle label found on page 1 of this document.

Note: Final Manufacturer

The final-stage manufacturer must also apply Tire Loading and Vehicle Alterer labels.

Sample Calculation - Ram Pickup FMVSS/ CMVSS † 105 Compliance, Chassis Cab (>7,716 lb/ 3,500 kg GVWR)

Example:

Subsequent manufacturer wishes to add a 260-lb (118 kg) winch to the front bumper and a 1,110-lb (503 kg) body to a 140.5" wheelbase 2500 HD 4x2. The midpoint of the winch will be 181.4" from the centerline of the rear axle directly above the frame rails. The body will be placed directly behind the cab and its floor will be directly above the frame rails. Can the modification be done without negating FMVSS/ CMVSS † 105 compliance?

Solution:

First, determine the location of the center of gravity of the individual components to be added. For the purposes of this example, the center of gravity (CG) of the winch is 5 inches above its base and at its exact center in the fore and aft direction. The CG of the body is 7.5 inches above its floor and 63.2 inches from its front in the fore and aft direction. (See illustration below).

Second, calculate the combined CG of the winch and body in the fore and aft direction. To find the combined CG, the weight of the winch is multiplied by the distance of its CG from the centerline of the rear axle. This result is then divided by the total weight of the components.

$$X = \frac{6.3" \times 1,110 \text{ lb} - 181.4" \times 260}{(1,110 \text{ lb} + 260 \text{ lb})} = -29.3$$

A negative value for "X" indicates that the CG is in front of the rear axle centerline.

Note: If all added component CGs are behind the rear axle, then the respective weight times CG distance results are added together before being divided by total weight.

Third, calculate Ymax from the equation $Y_{max} = B - 1.6(X)$. We use this equation because the CG of the added components is in front of the rear axle.

From the "B" factor table, "B" for a 1,370 lb load for a 140.5 inch wheelbase is about 140.

Therefore, $Y_{max} = 140 - 1.6(-29.3) = 186.9$ inches.

Fourth, calculate the combined vertical CG of the added components (Y) by multiplying the CG height of each component by the weight of each component, adding the results and dividing by the total weight of components:

$$Y = \frac{5" \times 260 \text{ lb} + 7.5" \times 1,110 \text{ lb}}{(260 \text{ lb} + 1,110 \text{ lb})} = 7.0"$$

Note:

If an added component's CG was below the frame rail datum line, then its weight-times-CG-distance result would be subtracted from the weight-times-distance result of components with CGs above the frame rail datum line.

Fifth, compare the value of Y with Ymax. For the additional components to be installed without affecting the FMVSS/ CMVSS † 105 compliance, the value of Y must not exceed Ymax. In the above example, Y (7.0") is less than Ymax (186.9"). Therefore, the winch and body combination can be added.

Sample vehicle for CG calculation examples

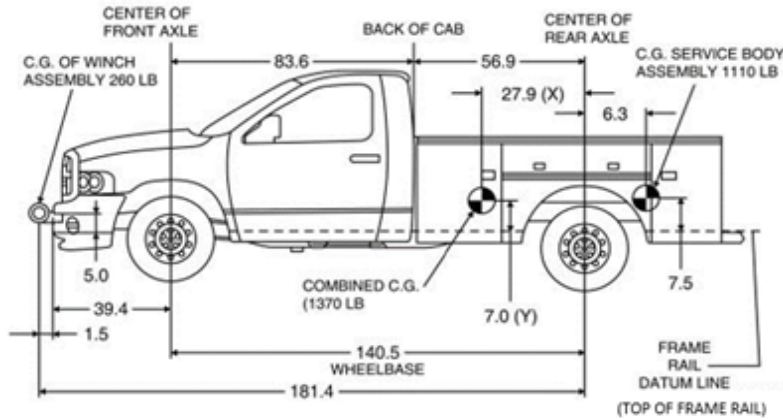

**INCOMPLETE VEHICLE AND HEAVY DUTY ENGINE INFORMATION INCOMPLETE VEHICLES
FEDERAL, CANADA AND CALIFORNIA (AND STATES ADOPTING CALIFORNIA EMISSION REGULATIONS)**

EXHAUST EMISSION CERTIFICATION PARAMETERS - INCOMPLETE VEHICLE - BOX OFF PACKAGES

The gasoline powered trucks listed below will conform with all Federal, Canadian or the State of California (and states adopting California emission requirements) exhaust emission regulations applicable to the 2022 model year new heavy duty vehicles and medium duty vehicles, if the following conditions are not exceeded in completion of the vehicle.

Models Incomplete Vehicles **	Body Model	Engine Displacement	Sales Area	GVWR	Max Completed Vehicle Weight (MCVW lbs)	Max Completed Frontal Area (Sq Ft)
2500/3500 HD 4x2/ 4x4	DJ/D2	6.4L Gasoline	Federal, Canada, and California	*	*	*
3500 CC 4x2/ 4x4	DD/DF	6.4L Gasoline	Federal, Canada, and California	*	*	*

* See under hood Vehicle Emission Control Information (VECI) label or consult the Weight Chart Tables at www.ramtrucks.com (Body Builder's Guide). Requirements do not apply to those trucks equipped with Chrysler AS66RC transmissions.

FOR GASOLINE FUELED INCOMPLETE VEHICLES

FUEL VAPOR RECOVERY (GASOLINE FUELED VEHICLES) - CALIFORNIA, AND STATES ADOPTING CALIFORNIA EMISSION REGULATIONS

The following information applies to gasoline fueled vehicles for sale or use in the state of California and states adopting California emission regulations. California regulations require that the fuel systems be designed to accommodate a vapor recovery fueling nozzle including unobstructed access to the fill pipe. Fuel filler pipes installed according to the instructions provided in the fuel filler kit will comply with the "Specifications for Fill Pipes and Openings of Motor Vehicle Fuel Tanks", referenced in Title 13 California Administrative Code providing no part of the second body, as installed, intrudes into the nozzle access zone.

ADDITIONAL MODIFICATIONS INFORMATION FOR FEDERAL, CANADA AND CALIFORNIA, AND STATES ADOPTING CALIFORNIA EMISSION REGULATIONS

The term "second bodies" includes not only the basic body or body structure but also any equipment permanently attached to the vehicle installed by the vehicle alterer

- None of the following fuel system components as installed by FCA US LLC are to be removed, replaced, relocated, altered or modified in any way:
 - Fuel tank and attachment hardware, including sending unit and vapor valve
 - Fuel lines, routing and attachments, excluding fuel filler cap, filler pipe, filler hose and filler system attachment hardware
 - Vapor line and carbon canister (Gasoline only)
 - Fuel pump
 - Leak detection system (Gasoline only)
 - Fuel filler and attachment
 - Throttle body
 - Air cleaner assembly
- No additional fuel tanks may be added.
- Any alteration or modification made to the vehicle as manufactured by FCA US LLC, and components or structure installed by the vehicle alterer must not result in penetration, separation or other damage to the fuel system or any portion thereof when the vehicle is tested in any manner specified by applicable provisions of FMVSS/CMVSS 301.
- The second body installed and the required fuel system components (identified below) must be located and mounted as follows:
 - Second body components must not contact any fuel system components (other than at the points where the fuel system is permanently attached to the second body)
 - Second body deformation or movement relative to the frame must not cause any fuel system component to be penetrated, disconnected or otherwise damaged
 - The rear end of the second body (excluding the rear bumper) installed must not extend beyond (overhang) the rear edge of the vehicle frame or frame extension. Any extension of the vehicle frame must be constructed and attached so as to perform as a continuation of the vehicle frame when the altered vehicle is tested in any manner specified by applicable provisions of FMVSS/CMVSS 301.
 - The fuel filler cap, filler pipe, filler hose and filler system attachment hardware must be installed according to the instructions provided in fuel filler kit and must be securely retained to remain intact when the vehicle is tested in any manner specified by applicable provisions of FMVSS/ CMVSS 301.

CALIFORNIA GREEN HOUSE GAS (GHG) REGULATION

The state of California limits refrigerant leakage as determined per SAE J2727 FEB2012 to 11 g/year or 1.5% of the refrigerant capacity per year (whichever is greater) per 17 CCR 95663. This vehicle will conform to the leakage requirement in 17 CCR §95663 if no alterations are made to the vehicle's air conditioning system as delivered, and no additional air conditioning systems are added. If the vehicle air conditioning system is modified in any way, or air conditioning systems are added, the final-stage manufacturer must ensure the complete vehicle complies with the requirement in 17 CCR §95663 and report that compliance to the California Air Resources Board. Please reference the vehicle's 'Design Recommendations and Cautionary notes' in the Body Builder guide for the refrigerant systems leakage information.

HEAVY DUTY ENGINE CERTIFICATION INFORMATION

FEDERAL, CANADA AND CALIFORNIA AND STATES ADOPTING CALIFORNIA EMISSION REGULATIONS

The following vehicles are certified under Federal, Canadian or the State of California and states adopting California Emission Regulations heavy duty engine certification regulations and NO emission related curb weight and frontal area restrictions apply.

MODELS	BODY MODEL	ENGINE DISPLACEMENT	TRANSMISSION	SALES AREA
3500/4500 - 5500 RAM 4x4, 4x2 Chassis Cab	DD/ DP	6.7L Diesel	AS69RC	Federal, Canada, and California
3500 RAM 4x4, 4x2 Chassis Cab	DD	6.4L V8 Gas	8HP75 AS66RC	Federal, Canada, and California
4500 - 5500 RAM 4x4, 4x2 Chassis Cab	DP	6.4L V8 Gas	AS66RC	Federal, Canada, and California

B Factors for Determining Center of Gravity - Ram 2500/ 3500 Pickup/ Chassis Cab								
Weight of Components Added by Subsequent Manufacturer (lbs)	Ram 2500/ 3500 (DJ/D2)			Ram 3500 Chassis Cab (DF-DD)				
	Reg Cab	Crew Cab		Reg Cab			Crew Cab	
	140.5"WB	149.4"WB	169.4" WB	143.5" WB C/A 60"	143.5" WB C/A 60"	167.5" WB C/A 84"	172.4" WB C/A 60"	172.4" WB C/A 60"
B Factors	B	B	B	B	B	B	B	B
Rear Axle Type	SRW	SRW	SRW	SRW	DRW	DRW	DRW	DRW
250 lbs (Minimum allowable added weight for 2500)	140	140	140	---	---	---	---	---
500 lbs	140	140	140	---	---	---	---	---
750 lbs	140	140	140	---	---	---	---	---
1,000 lbs	140	140	140	130	130	130	130	130
1,250 lbs	140	140	140	---	---	---	---	---
1,500 lbs	140	140	140	---	---	---	---	---
1,750 lbs	140	140	140	---	---	---	---	---
2,000 lbs	140	140	140	125	125	125	125	125
2,250 lbs	140	140	140	---	---	---	---	---
2,500 lbs	140	140	140	---	---	---	---	---
2,750 lbs	140	140	140	---	---	---	---	---
3,000 lbs	134	134	134	120	120	120	120	120
3,250 lbs	128	128	128	---	---	---	---	---
3,500 lbs	122	122	122	---	---	---	---	---
3,750 lbs	116	116	116	---	---	---	---	---
4,000 lbs	110	110	110	---	115	115	---	115

B Factors for Determining Center of Gravity - Ram 4500 Chassis Cab						
Weight of Components Added by Subsequent Manufacturer (lbs)	Ram 4500 Chassis Cab (DP)					
	Reg Cab	Reg Cab	Reg Cab	Reg Cab	Crew Cab	Crew Cab
	144.5"WB C/A 60"	168.5"WB C/A 84"	192.5" WB C/A 108"	204.5" WB C/A 120"	173.4" WB C/A 60"	197.4" WB C/A 84"
B Factors	B	B	B	B	B	B
Rear Axle Type	DRW	DRW	DRW	DRW	DRW	DRW
1,000 lbs	130	130	130	130	130	130
2,000 lbs	125	125	125	125	125	125
3,000 lbs	120	120	120	120	120	120
4,000 lbs	115	115	115	115	115	115
5,000 lbs	110	110	110	110	110	110
6,000 lbs	105	105	105	105	105	105
7,000 lbs	100	100	100	100	100	100
8,000 lbs	95	95	95	95	95	95

B Factors for Determining Center of Gravity - Ram 5500 Chassis Cab						
Weight of Components Added by Subsequent Manufacturer (lbs)	Ram 5500 Chassis Cab (DP)					
	Reg Cab	Reg Cab	Reg Cab	Reg Cab	Crew Cab	Crew Cab
	144.5"WB C/A 60"	168.5"WB C/A 84"	192.5" WB C/A 108"	204.5" WB C/A 120"	173.4" WB C/A 60"	197.4" WB C/A 84"
B Factors	B	B	B	B	B	B
Rear Axle Type	DRW	DRW	DRW	DRW	DRW	DRW
1,000 lbs	130	130	130	130	130	130
2,000 lbs	125	125	125	125	125	125
3,000 lbs	120	120	120	120	120	120
4,000 lbs	115	115	115	115	115	115
5,000 lbs	110	110	110	110	110	110
6,000 lbs	105	105	105	105	105	105
7,000 lbs	100	100	100	100	100	100
8,000 lbs	95	95	95	95	95	95
9,000 lbs	90	90	90	90	90	90
10,000 lbs	85	85	85	85	85	85
11,000 lbs	80	80	80	80	80	80

SRW = Single Rear Wheel

DRW = Dual Rear Wheel

NOTE: See FMVSS/ CMVSS 301 for further weight limitations

NOTE: Box Delete is only available on Reg Cab or Crew Cab