

Views & Charts 2500 Pickup
 Regular Cab, 8' Box – Box Off

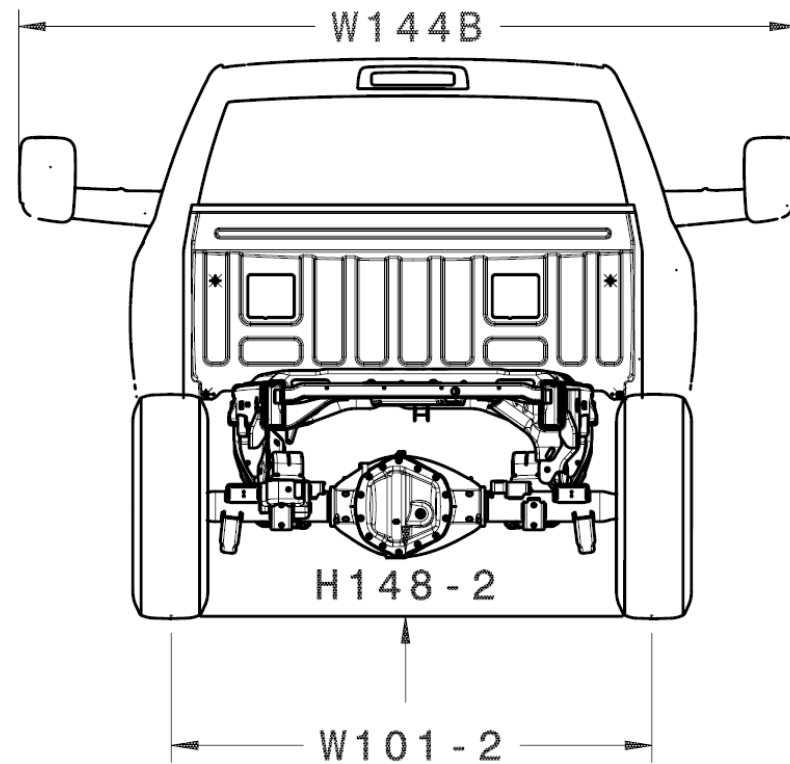
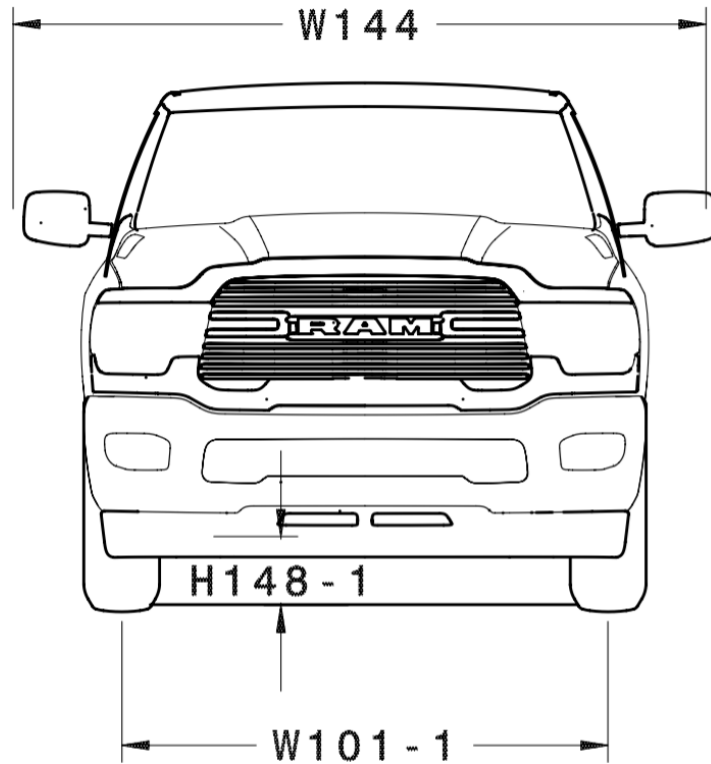

**Views & Charts 2500 Pickup
Regular Cab, 8' Box – Box Off**

Code	Description	275/70R18	
		Metric	English
A106-1	Angle of Approach	22.8 deg	22.8 deg
A106-2	Angle of Departure	24.9 deg	24.9 deg
A147	Ramp Breakover Angle	21.4 deg	21.4 deg
CG_H511	Bottom of Open Hood to Ground	2212.9 mm	87.1 in
CG_L105	Rear Axle to Rear Edge of Frame	1054.6 mm	41.5 in
CG_TRH7	Top of Frame(at rear) to Ground	916.6 mm	36.1 in
CG_TT18	Turn Circle Diameter (feet/meters)*	13.9 m	45.5 ft
H5-1	SgRP to Ground - Front	1052.7 mm	41.4 in
H101	Vehicle Height(curbLoad)	2037.0 mm	80.2 in
H103-1	Fascia(Bumper) to Ground - Front	277.2 mm	10.9 in
H108-1	Static Load Radius - Front Tire *	395.7 mm	15.6 in
H108-2	Static Load Radius - Rear Tire *	405.9 mm	16.0 in
H130-1	Step Height - Front	698.8 mm	27.5 in
H148-1	Suspension or Axel to Ground - Front	237.0 mm	9.3 in
H148-2	Suspension or Axel to Ground - Rear	217.0 mm	8.5 in
L101	Wheelbase	3560.0 mm	140.2 in
L104	Overhang - Front	1036.8 mm	40.8 in
L105	Overhang - Rear	1275.3 mm	50.2 in
L114	Front Wheel Centerline toSgRP - Front	1471.6 mm	57.9 in
L404	Cab to Rear Axle (CA)	1444.0 mm	56.9 in
W101-1	Tread Width - Front Tires	1719.0 mm	67.7 in
W101-2	Tread Width - Rear Tires	1703.6 mm	67.1 in

**Views & Charts 2500 Pickup
Regular Cab, 8' Box – Box Off**

Code	Description	Metric	English
CG_TRL2	Fuel Tank Length	1647.3 mm	64.9 in
CG_TRL3	Rear Wheel Center line to Fuel Tank	166.6 mm	6.6 in
CG_TRL4	Back of Cab to Taillamp	2655.7 mm	104.5 in
L103	Vehicle Length	5872.1 mm	231.2 in
L403	Front Bumper to Back of Cab (BBC)	3153.8 mm	124.2 in
L404	Cab to Rear Axle (CA)	1444.0 mm	56.8 in
L410	Cab Length	1838.4 mm	72.4 in

Code	Description	Metric	English
A18	Steering Wheel Angle	22.9 deg	22.9 deg
A130-1	Glazing Angle - Windscreen	56.4 deg	56.4 deg
CG_A18	Steering Column Angle	23.4 deg	23.4 deg
CG_TRH4	Top of Frame to top of Cab	1158.0 mm	45.6 in
CG_TRH6	Top of Frame to Top of Fuel Tank	22.5 mm	0.9 in
H6	SgRP - Front to Windshield Lower DLO	405.8 mm	16.0 in
H61-1	Effective Head Room - Front	1011.0 mm	39.8 in

Code	Description	Metric	English
CG_FW5	Rear Frame - Inside Width	922.0 mm	36.3 in
CG_FW6	Rear Frame - Outside Width	1062.0 mm	41.8 in
CG_TRW1	Outside Rail to Fuel Tank(inside)	438.2 mm	17.3 in
CG_TRW6	Outside Of Rear Tires	1979.4 mm	77.9 in
W144	Vehicle Width-Mirrors Included (Std)	2463.3 mm	97.0 in
W144B	Vehicle Width-Mirrors Included (Trailer)	2776.1 mm	109.3 in
W106	Fender Width - Front	2010.2 mm	79.1 in
W117	Body Width At SgRP - Front	2005.1 mm	78.9 in
W120-1	Vehicle Width, Doors Open - Front	4513.7 mm	177.7 in

Views & Charts 2500 Pickup
Regular Cab, 8' Box – Box Off

- Height dimensions on page 3 are for 4x4 drive line and steel spring suspension
- Ground and Axle referenced dimensions will be different (smaller/lower) on 4x2 vehicles
- To determine heights for other drive line/suspension configurations, subtract the values in the chart below from the applicable height dimensions on page 3

2500 (DJ) Height Variations From 4x4		
Suspension Configuration	Front	Rear
4x2 Spring	-51 mm, -2.0 in	-47 mm, -1.8 in