

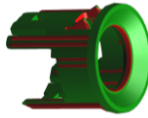
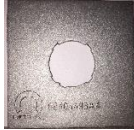

OVERVIEW

Ram cab chassis can be ordered with a front and rear Park Sense system (sales code XAG) or a rear only Park Sense system (sales code XAA). The Park Sense system uses sound waves to detect nearby obstacles in and near the path of the vehicle to help you maneuver in tight spaces at parking speeds. Audiovisual indicators alert you to the proximity of most larger, stationary objects that might be outside your line of sight.

If a cab chassis is equipped with a Park Sense front and rear or rear only system, the customer is responsible for installing the sensors and mounting hardware that comprises the rear system. The in-cab controls, chassis wiring, and front sensors have been factory installed. A kit containing all required hardware for the rear system installation is provided and can be found in the cab of the vehicle. Once located, take an inventory of the kit's contents to confirm it is complete before installation. **Table 1** below details the kit's content and should be used for reference.

Table 1: Rear Park Sense Kit Contents			
Quantity	Part Number	Description	Picture
4	6MK25GXHAA	Parking Sensor	
4	68404385AA	Bezels	
4	68404493AA	Metal Coupons	
1	68397412AA	Rear Park Assist Jumper	

Loose Ship Park Sense Upfitter Guide

REAR PARKSENSE SYSTEM

System as Delivered

Since rear Park Sense is not installed and configured off from the factory, the indicator light on the rear Park Sense button (**Figure 11**) located within the center stack, will be illuminated indicating the system is disabled. Additionally, if the rear Park Sense button is pressed with the sensors disconnected the indicator light will flash briefly and return to its illuminated state.

Cab chassis ordered with a rear only system will have no cluster pop up or Park Sense related tones until the rear sensors are installed. Those ordered with front and rear Park Sense will have cluster pop ups and tones related to the front sensors only when the vehicle is in reverse (**Figure 8**) and while the driving forward at low speeds.

Rear Sensor Placement

The sensors provided for a rear Park Sense system are only intended to be mounted on the rear of the vehicle per the following installation instructions; they cannot be used in any other orientation or function.

In order for the Park Sense system to work properly, the sensors should be between 62 and 72 centimeters (24.4 and 28.4 inches) from the ground at the Completed Vehicle Weight. If the sensors are too close to the ground, the system may falsely detect the ground as an obstacle. Whereas the higher the sensors are mounted above 72 centimeters, (28.4 inches) the taller an object must be for it to be detected. To help the installer determine a mounting height **Appendix A** provides a reference of frame rail height to ground at curb and GAWR (Gross Axle Weight Rating) for all chassis cabs. This frame rail height must be measured above the axle and not at the end of the frame.

The sensors should be placed in a straight horizontal line across the back of the vehicle with two sensors 27.5 centimeters (10.8 inches) left and right of the vehicle's centerline and the other two sensors 80.5 centimeters (31.7 inches) left and right of the vehicle's centerline. The mounting depth between sensors cannot vary more than 10 centimeters. **Figure 1** visually represents the parameter window in which the sensors can be mounted.

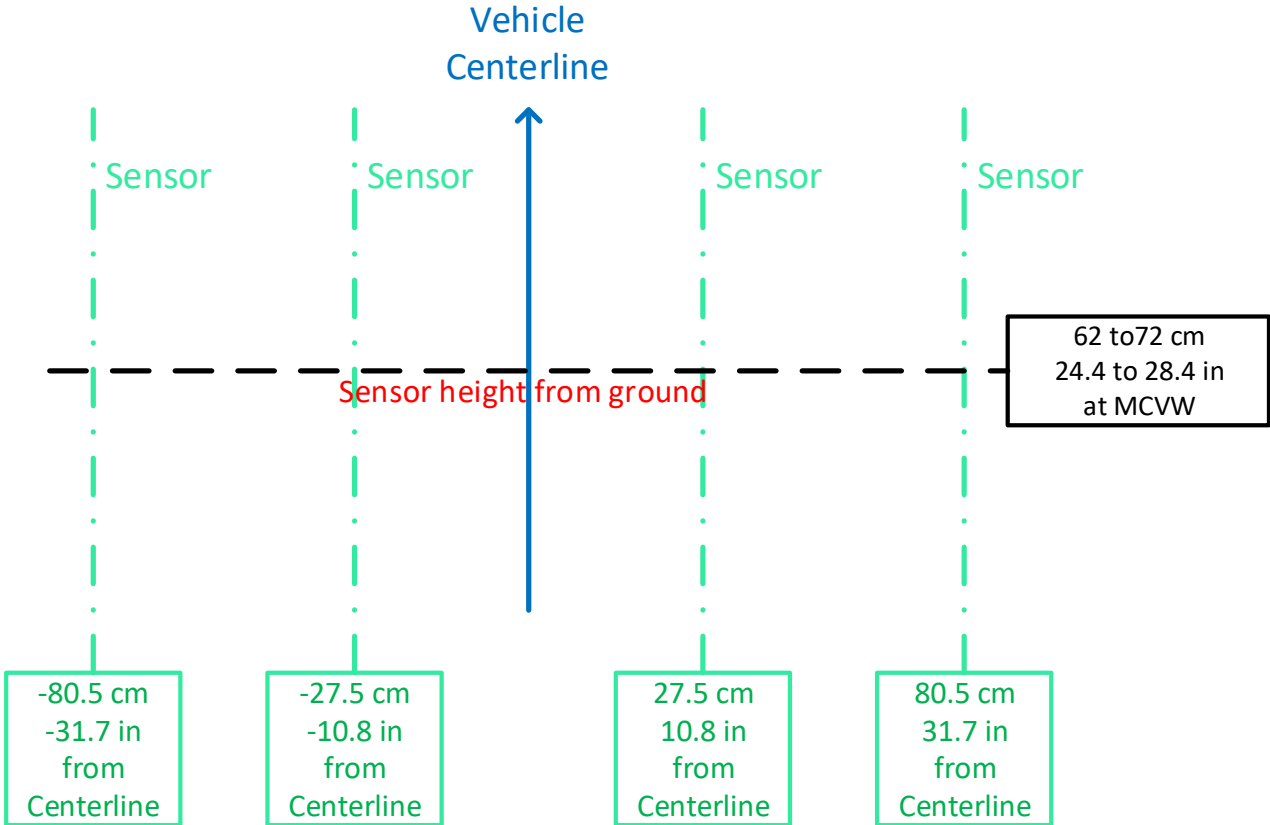

Figure 1: Parameter window in which Park Sense Sensors can be mounted

Figure 2 and Table 2 shows the sensor’s vision field in red which must remain clear of obstructions. Whereas the green regions can have obstructions present that the Park Sense sensor will not detect. If an obstruction falls within the field of view, the sensors will continuously report the obstruction and the chime will sound.

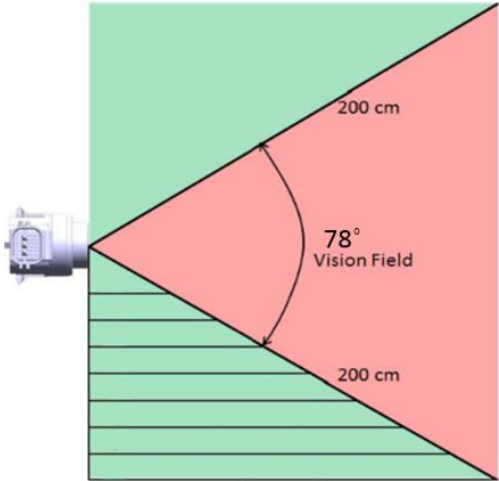

Figure 2: ParkSense’s Vertical Vision Field – Side View

Loose Ship Park Sense Upfitter Guide

Position	Distance Along Z from Sensor (cm)	Distance from Vision Field Back to Sensor Face Z (cm)
1	20	14
2	40	28
3	60	42
4	80	56
5	100	70
6	120	84
7	140	98
8	164	114.8

Table 2. Dimensions for Figure 2

If the installer of the system cannot guarantee that the sensors will be located within the limits specified in this section, it is the installer's responsibility to ensure that the Park Sense system will meet the requirements of their customer.

Steel Coupon Attachment

When deciding upon a location to mount the sensor and coupon on the back of the vehicle it is critical that the coupon mounts perpendicular to the ground as shown in **Figure 3**. If this requirement is not met, the sensor's vision field shown in **Figure 2** will be skewed and the Park Sense system's performance will not be optimal.

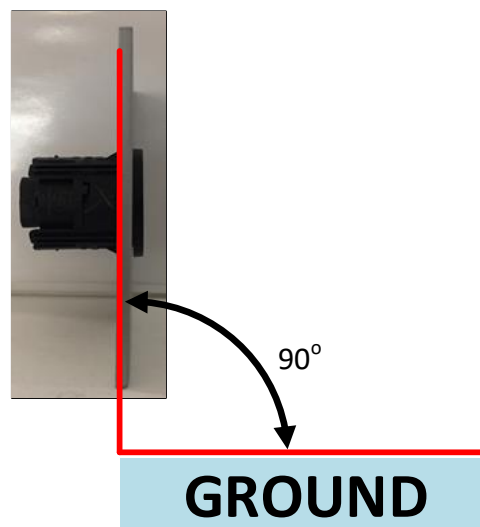

Figure 3: Sensor Mounting Requirement with Ground

Loose Ship Park Sense Upfitter Guide

While attaching the coupon to the vehicle it is important to make sure that the index keying in the mounting coupon is as shown in **Figure 4**. The sensors and bezels should be inserted into the coupon such that the sensor is orientated as shown in **Figure 5** with the connector on the horizontal plane of the vehicle, not the vertical. The sensors outputs are symmetric. So, it does not matter whether the sensor connectors are on the left or right of the sensor. It is possible to have some sensors with the connector on the right side and others with the connector on the left.

NOTE: When installing the bezel into the coupon, pay attention to the keying. It is possible to force the bezel into the coupon without having the keys aligned properly.

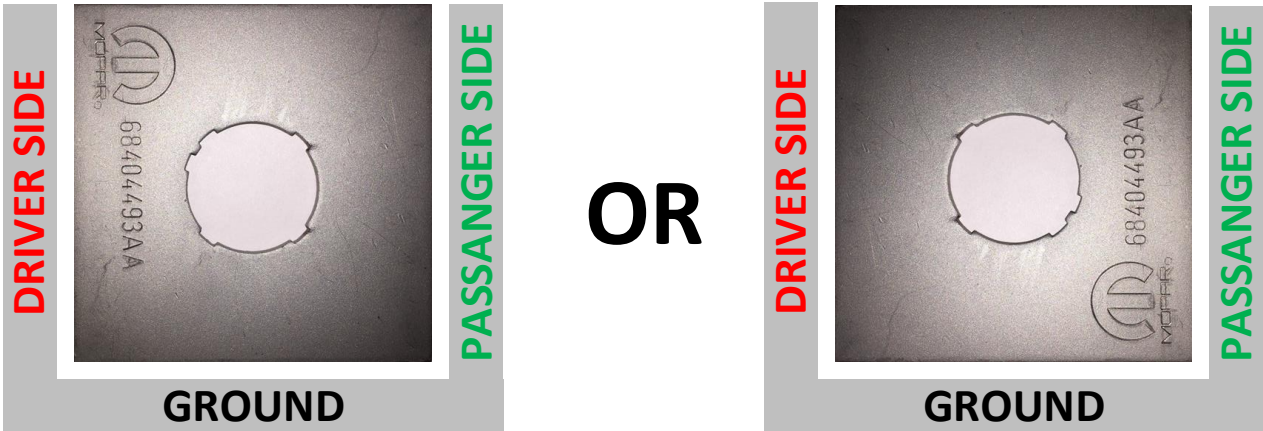

Figure 4: Correct Coupon Mounting Orientation
This Surface Faces Out (Towards Rear of Vehicle)

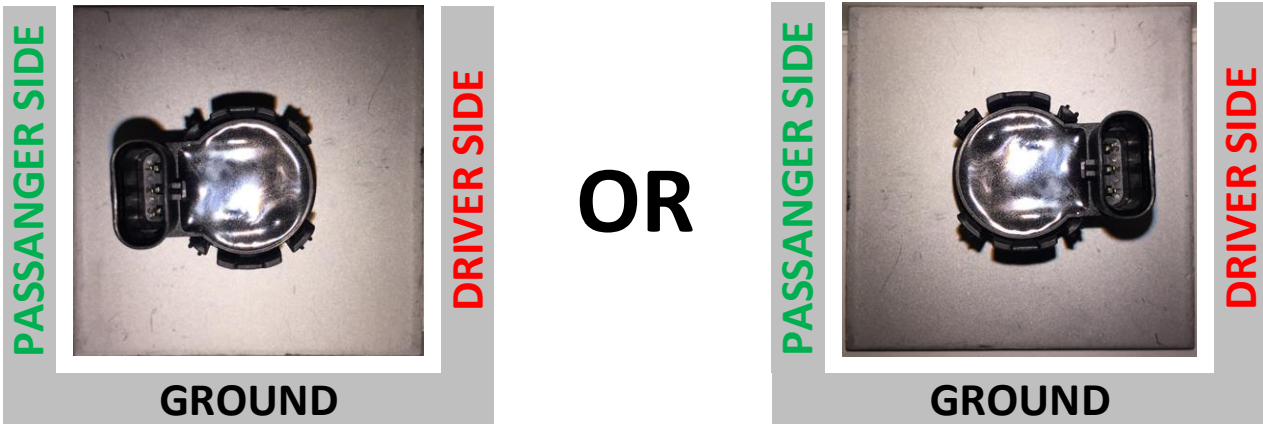

Figure 5: Correct Sensor Mounting Orientation
View of Back (Forward Facing) Side of Coupon

Loose Ship Park Sense Upfitter Guide

The use of the steel coupon is not mandatory. However, if the coupon is not used, please follow the dimensions outlined in **Figure 6** to reproduce the required hole and keying for the Park Sense bezel in the body.

The 2D layout in **Figure 6** is shown on the back (forward facing) side of the coupon as seen in **Figure 5**.

This feature is available in a CAD model if the hole and keys are cut using CNC equipment.

Material thickness is critical to make sure that the bezel snaps firmly in place.

If the coupon is used, it is recommended that a surface treatment be applied before and/or after mounting, but prior to sensor installation, to prevent corrosion.

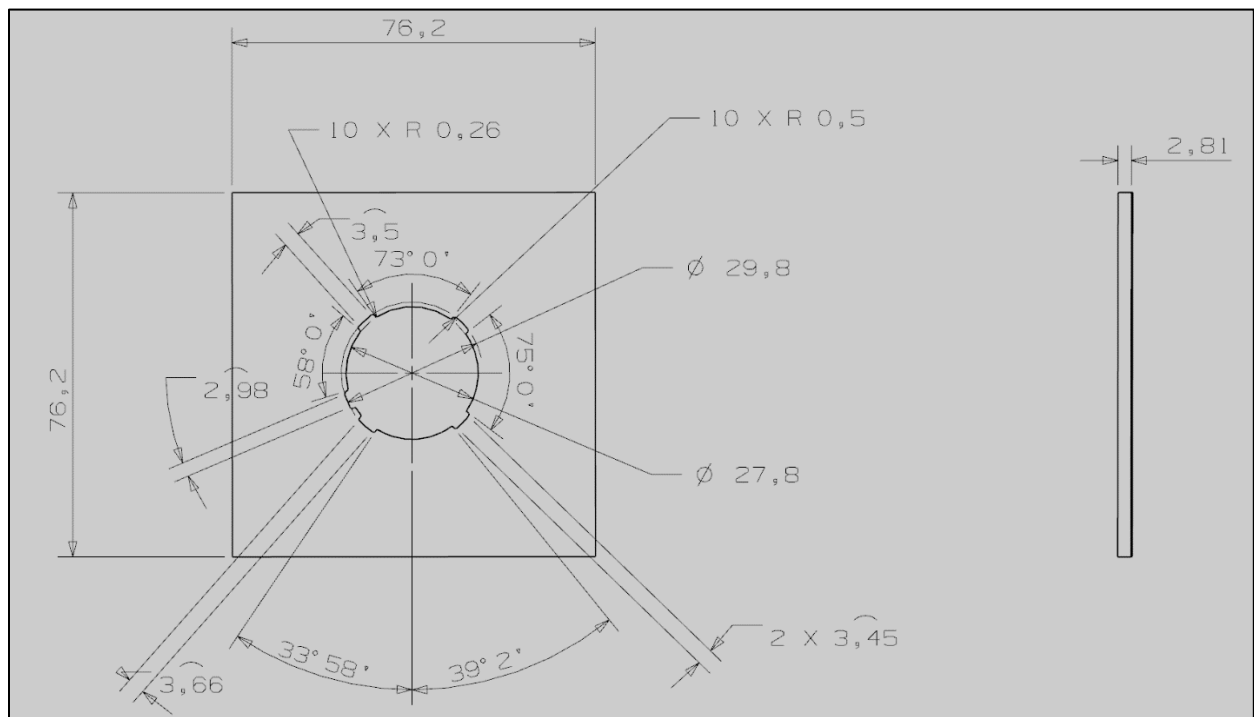

Figure 6: Body Bezel Hole Dimensions in Millimeters

Loose Ship Park Sense Upfitter Guide

Wiring

With the four sensors installed onto the body, plug the sensors into the wiring harness. The 6 pin connector must be plugged into the factory installed connector which is located between the frame rails. **Figure 7** shows the physical location of the factory connector. Depending on option content, there may be several connectors in this area which are capped. The sensor harness will only mate with the connector which has the male connector on the vehicle side (plug and sensor harness connector will be female). Once everything is connected make sure the wires are secured and nothing is hanging loose that could be snagged.

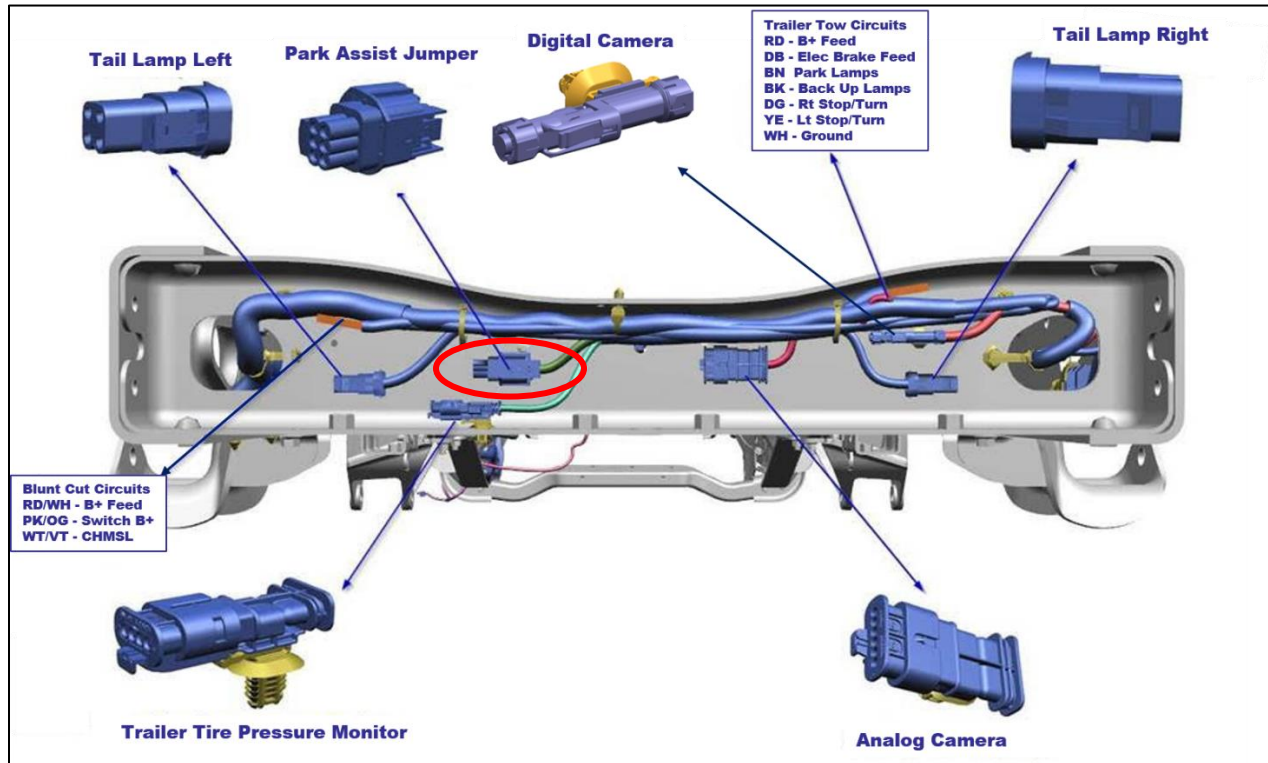

Figure 7: Factory Park Sense Connector Location

Finally, it's important that the sensors are wired in the proper order. Sensor assignment can be assured by matching the appropriate wire color to the proper sensor location using **Table 3**.

Table 3: Rear Sensor Wire Color Assignment		
Function	Color	Sensor Location
Sensor Shared Ground	Grey/Blue	All
Sensor Shared Power	Grey/Orange	All
Sensor 8 Signal	White/Blue	Right Outer
Sensor 9 Signal	White/Orange	Right Inner
Sensor 10 Signal	White/Dark Green	Left Inner
Sensor 11 Signal	White	Left Outer

Loose Ship Park Sense Upfitter Guide

Front Park Sense System

System as Delivered

Cab chassis ordered with a front and rear Park Sense system will come delivered with the front sensors installed and enabled. There is nothing that the customer needs to do to begin using the front park sensors. The indicator light on the front Park Sense button will be off indicating the system is functional. If desired, object detection notifications can be temporarily mitigated by pressing the front button, causing the light to become illuminated. The front sensors are active any time the vehicle is in reverse and also during low speed maneuvers while the vehicle is traveling forward. The graphics that will display in the instrument cluster with only the front system installed can be seen in **Figure 8**.

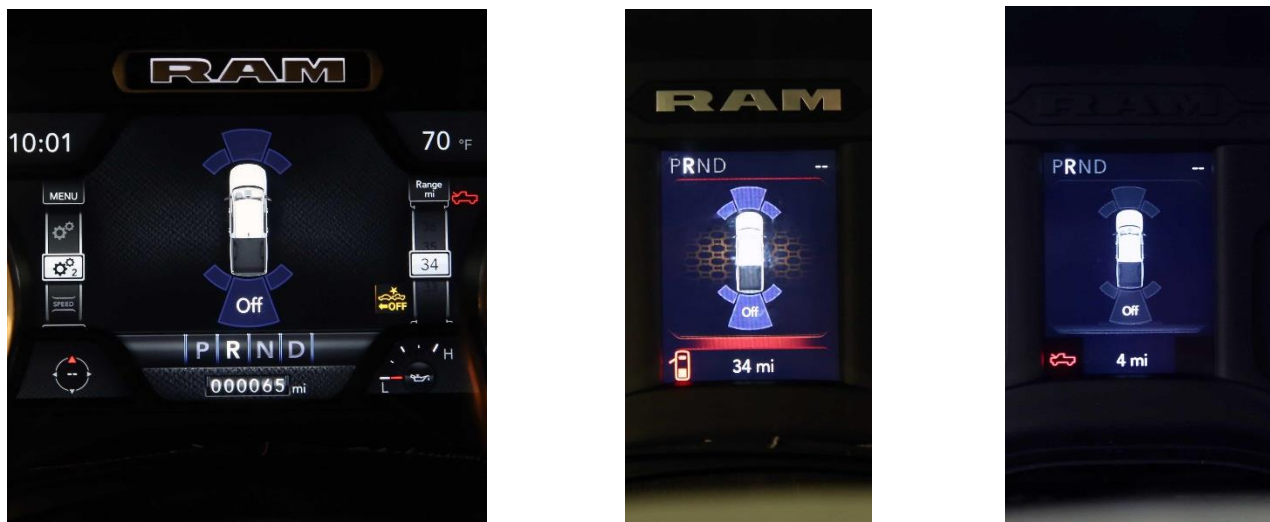

Figure 8: Instrument Cluster Graphic With Only Front Sensors Installed (High-line Cluster Left – Mid-line Cluster Center – Low-line Cluster Right)

Wiring

Table 4 is provided for reference should modification of the front harness need to take place.

Table 4: Front Sensor Wire Color Assignment		
Function	Color	Sensor Location
Sensor Shared Ground	Grey/Blue	All
Sensor Shared Power	Grey	All
Sensor 1 Signal	White/Yellow	Left Outer
Sensor 2 Signal	White/Orange	Left Center
Sensor 3 Signal	White/Tan	Left Inner
Sensor 4 Signal	White/Green	Right Inner
Sensor 5 Signal	White/Blue	Right Center
Sensor 6 Signal	White/Brown	Right Outer

Loose Ship Park Sense Upfitter Guide

GENERAL SYSTEM INFORMATION

Front or Rear System Activation and Deactivation

With the ignition in run position and the vehicle in park, access the “Commercial Settings” menu within the instrument cluster using the steering wheel controls. On vehicles without a touch screen radio, the “Commercial Settings” menu is available in the EVIC under “Vehicle Settings”. For vehicles with touch screen radios, the “Commercial Settings” menu is one of the top level display options in the EVIC. Once inside “Commercial Settings”, enter your unique four-digit pin (default is 0000) and select “Park Sense”. Following the logic outlined in **Figure 9** select the appropriate sensor and set it as installed or uninstalled. The factory default setting for “Front Sensor” is “Enable”. For “Rear Sensor” the default is “Disabled”. Once a setting has been changed, turn the key to the off position, wait until the instrument cluster screen turns off, and then key back on.

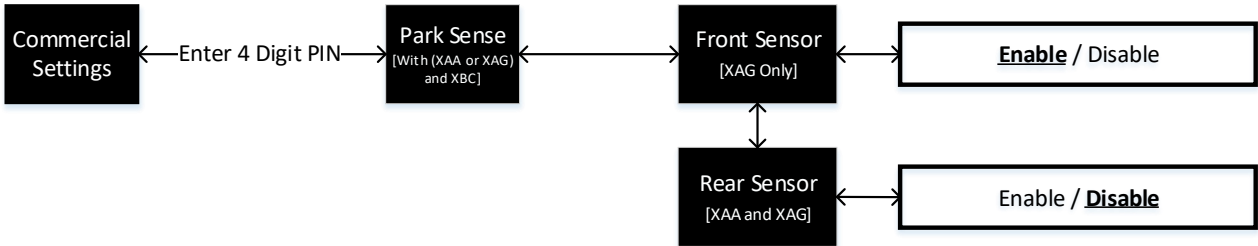

Figure 9: Instrument Cluster Park Sense Programming Menu

Unlike model years 2018 and older, the vehicle will no longer auto detect the installation the rear system. The rear sensors must be enabled in the programming menu. If the system is enabled prior to the sensors being electrically connected, the system will set faults and a “Service Rear Parksense” message will occur in the cluster.

Validation of an Installed Park Sense System

Once installation is complete, please follow the four basic steps outlined below to confirm that the Park Sense system has been installed correctly. Ultimately these four steps provide a basic functionality check and it is the installer's responsibility to confirm that the Park Sense system functions properly.

1. With no obstructions behind the vehicle for at least 2.5 meters, set the park brake, start the engine, hold the service brake and shift the vehicle into reverse. Confirm that the Park Sense indicator light goes off (if it wasn't already) and that the Park Sense system does not detect an object. (no chimes and no bars behind vehicle displayed in instrument cluster) See **Figure 12**. Shift the vehicle back to park.



**Figure 10: Park Sense Buttons
(Indicators off)**



**Figure 11: Park Sense Buttons
(Indicators On)**

2. If the indicator light remains lit as shown in **Figure 11: Park Sense Buttons (Indicators On)** press the button and pay attention to the response. If a faulted condition exists, for example a sensor was not plugged in, the light will flash and remain lit. If the light goes out, restart this test.
3. If the system detects obstructions behind the vehicle (audio chime(s) and bar(s) behind vehicle displayed in instrument cluster **Figure 13**), verify that there are no obstructions within 2.5 meters of the rear of the vehicle. If no obstructions are present, review sensor installation to ensure sensors are installed within the guidelines provided.



**Figure 12 Instrument Cluster Graphic with no obstructions detected
(High-line Cluster Left – Mid-line Cluster Center – Low-line Cluster Right)**

Loose Ship Park Sense Upfitter Guide

With the vehicle back in park, place 3 sizable objects 1-meter rearward of the sensors, on the left, center and right of the vehicle. The minimum object size is a 1-meter-high pole 10 cm in diameter. With an object now behind the vehicle, hold the service brake and shift the vehicle into reverse. Confirm that the Park Sense system detects the object upon entering reverse gear. The graphic in the instrument cluster should now have bars behind it, **Figure 13**, and an audible chime should be heard.

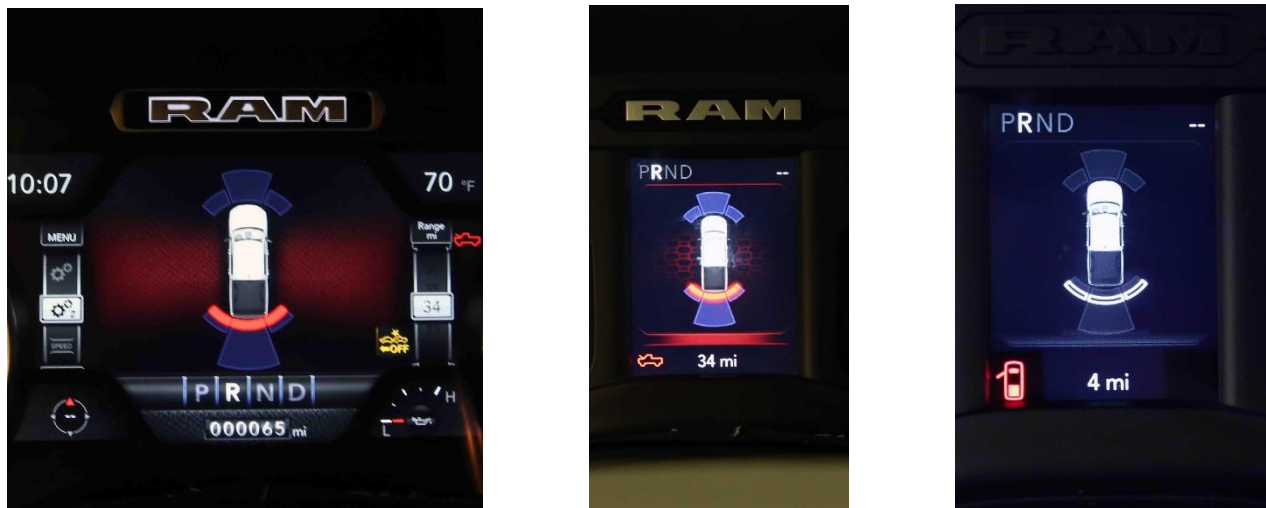

**Figure 13: Instrument Cluster Graphic with obstruction detected
(High-line Cluster Left – Mid-line Cluster Center – Low-Line Cluster Right)**

- In order for the vehicle to run an internal diagnostic check on the Park Sense System, a short test drive reaching a vehicle speed of at least 25 mph is required. Once complete and before keying the vehicle off, check the Park Sense button in the center stack to make sure the indicator light is not illuminated (**Figure 10**). If the indicator light is illuminated (**Figure 11**) an active fault in the Park Sense System may be present. To confirm the Park Sense button was not accidentally pressed at some point, press the Park Sense button. If the indicator light turns off, the system is working, you Park Sense validation is complete. If the indicator light blinks for a few seconds and then remains on, a fault is present that must be diagnosed and fixed before the system will be functional.

Removal of a Park Sense System

If you decide to remove the Park Sense system, simply unplug the sensor harness from the body wiring harness and reinstall the cap back into the body side connector to protect it from corrosion. Next, go into “Commercial Setting” and select that the Park Sense menu. Then set the Rear Sensor to DISABLE. See “Front or Rear System Activation and Deactivation” for instructions for changing this setting. If the Park Sense sensors are not deactivated within the cluster, upon start-up and every time the vehicle is put into reverse, a service message will appear within the cluster.

Loose Ship Park Sense Upfitter Guide

Appendix A: Frame Rail to Ground Plane Height Chart

Class	Configuration	Wheelbase	Rear Wheel Configuration	Tire Size	Top of Rear Frame to Ground Dimension		Delta (Curb - GAWR)
					Curb Load (cm)	GAWR Load (cm)	
3500	Regular cab 60" CA	143.5	SRW	LT265/70R18E(TTV)	86.7	74.6	12.1
	Regular cab 60" CA		DRW	LT235/80R17E(TPY)	86.1	71.9	14.2
	Regular cab 84" CA	167.5	DRW	LT235/80R17E(TPY)	85.6	71.8	13.8
	Crew cab 60" CA	172.4	SRW	LT265/70R18E(TTV)	86.2	74.6	11.6
	Crew cab 60" CA		DRW	LT235/80R17E(TPY)	85.5	71.2	14.3
4500	Regular cab 60" CA	144.5	DRW	225/70R19.5 F	92.1	79.3	12.8
	Regular cab 84" CA	168.5	DRW	225/70R19.5 F	91.6	79.9	11.7
	Regular cab 108" CA	192.5	DRW	225/70R19.5 F	91.5	80.3	11.2
	Regular cab 120" CA	204.5	DRW	225/70R19.5 F	91.4	80.3	11.1
	Crew cab 60" CA	173.5	DRW	225/70R19.5 F	91.2	79.4	11.8
	Crew cab 84" CA	197.4	DRW	225/70R19.5 F	91.3	79.4	11.9
5500	Regular cab 60" CA	144.5	DRW	225/70R19.5 F	92.0	79.3	12.7
	Regular cab 84" CA	168.5	DRW	225/70R19.5 F	91.5	79.9	11.6
	Regular cab 108" CA	192.5	DRW	225/70R19.5 F	91.1	80.3	10.8
	Regular cab 120" CA	204.5	DRW	225/70R19.5 F	93.9	84.2	9.7
	Crew cab 60" CA	173.5	DRW	225/70R19.5 F	91.3	79.4	11.9
	Crew cab 84" CA	197.4	DRW	225/70R19.5 F	90.9	79.4	11.5