

PROMASTER CHASSIS STRUCTURAL MODIFICATIONS

MODIFYING REAR OVERHANG

Modifying the rear overhang causes a significant change in the weight distribution on the axles. Final stage manufacturers must take this into account, checking that the GVW and GAWRS are not exceeded.

The operation to modify the overhang must be carried out in accordance with the requirements given on the following pages.

In addition, the allowable lengthening operations are described in the diagrams (see following page), where the shaded area defines all the possible dimensions of the overhang in relation to the vehicle's wheelbase.

The modification must be made without making welds on chassis box sections, as this procedure would involve destroying the corrosion protection; in addition, the vehicle is already equipped with holes for fastening overhang extension structures (see following pages).

NOTE: - Do not make cuts in areas where stresses are highly concentrated. In addition the cutting lines must not affect existing holes on the longitudinal members.

For overhang lengthening instructions, see the following pages.

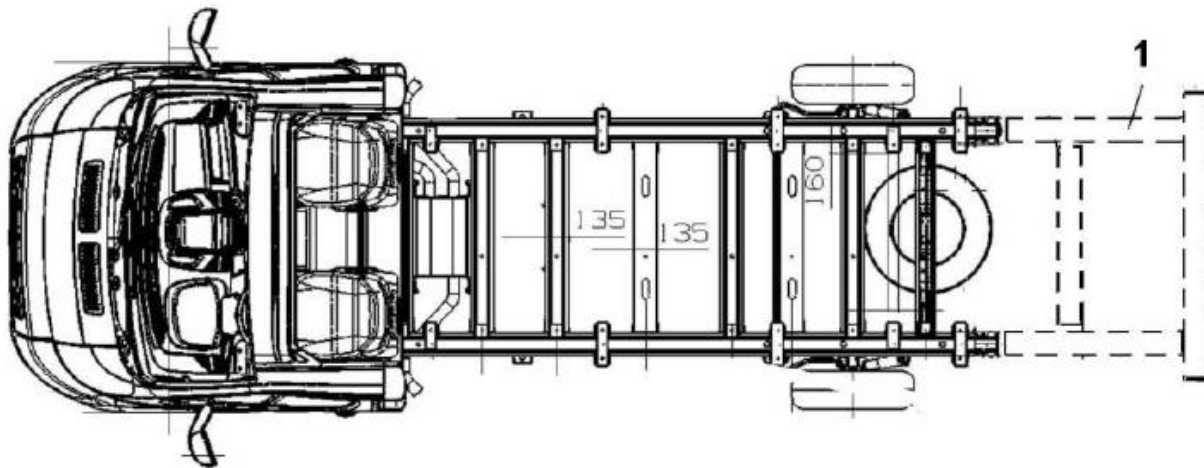

1: indicative outline of structure for lengthening overhang.

CHASSIS CAB LENGTHENING LIMITS

The permitted extensions to the overhang can be determined from the diagram below.

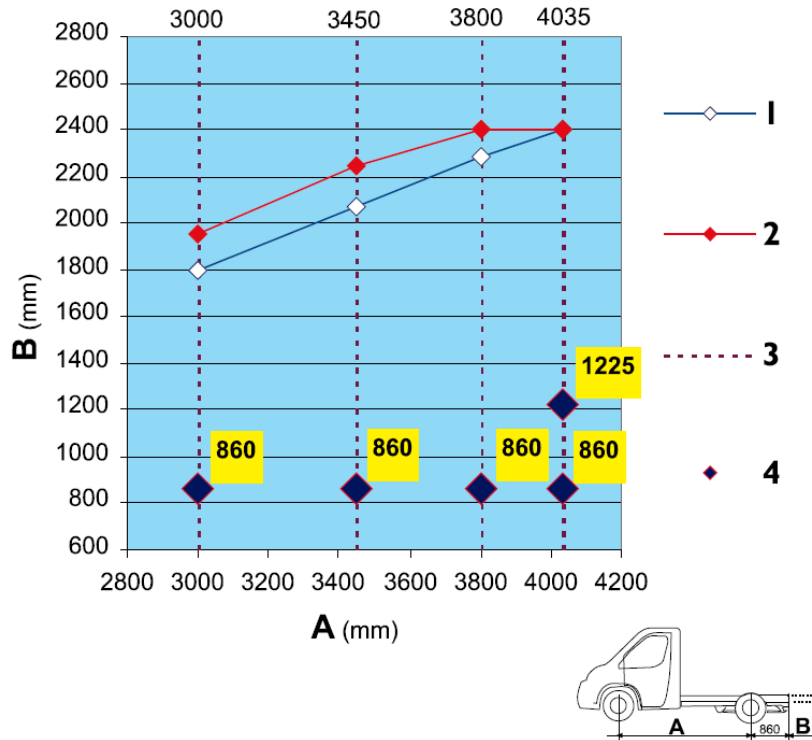

1. Maximum overhang length according to wheelbase (60% for all versions excluding Camping-car).

2. Maximum overhang limit according to wheelbase (65% for Camping-car versions).

3. Original wheelbase.

4. Original overhangs (*).

For all wheelbases that exceed 3800 mm the maximum length of the projecting part must not exceed 2400 mm.

(*) - Chassis cabs, chassis cab with platform and standard basic chassis: 860 mm; (extra-long overhang: 1225 mm).

- Special cabs, chassis cab with platform and special basic chassis: 880 mm;

(extra-long overhang: 1245 mm).

A: Wheelbase length.

B: Overhang length.

OVERHANG LENGTHENING LIMITS
 Normal chassis cab (with sub-frame)

Sections

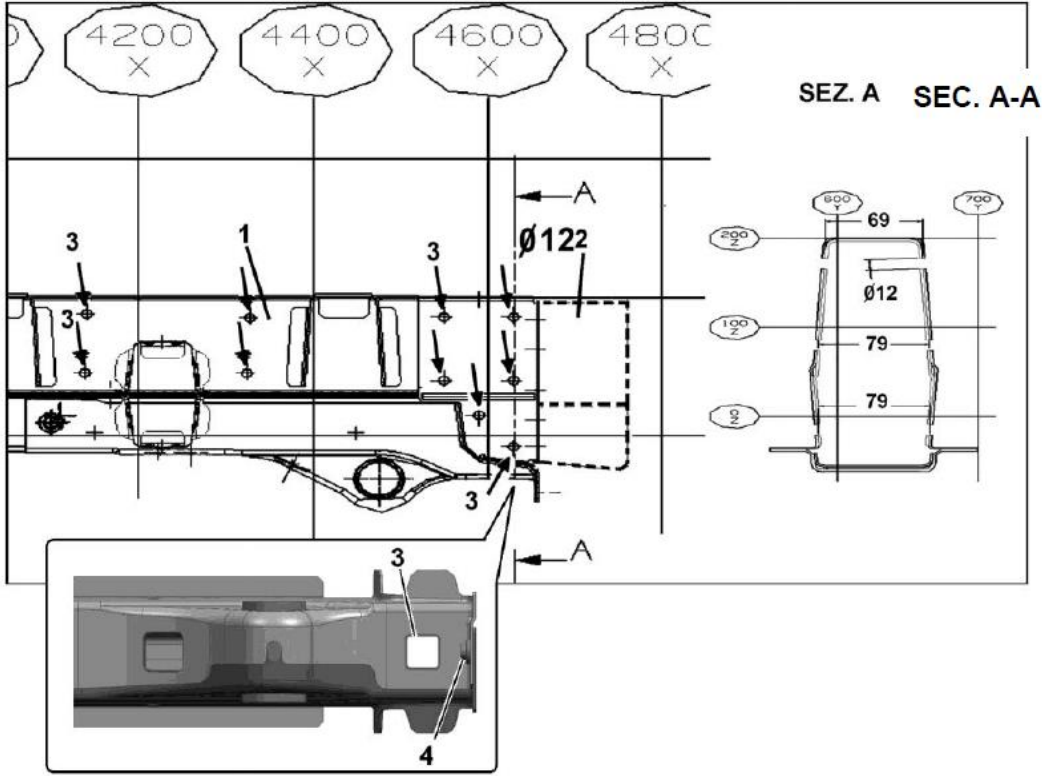

Perspective view

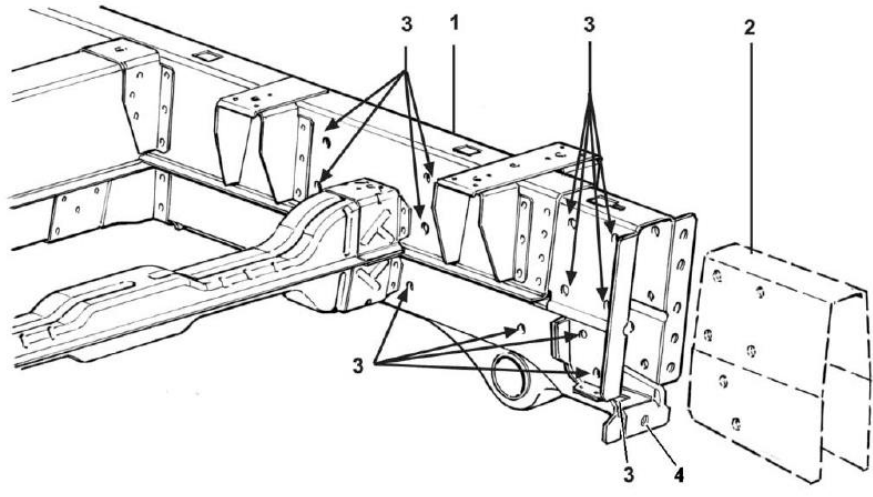

1: longitudinal member; 2: Upfitter added structure; 3: attachment holes 4: ring nut.

ProMaster Chassis Structural Modifications

ATTACHMENT PRE-FITTINGS

The drawing shows the pre-fittings for applying the towing hook. The solution is valid for all Camping car.

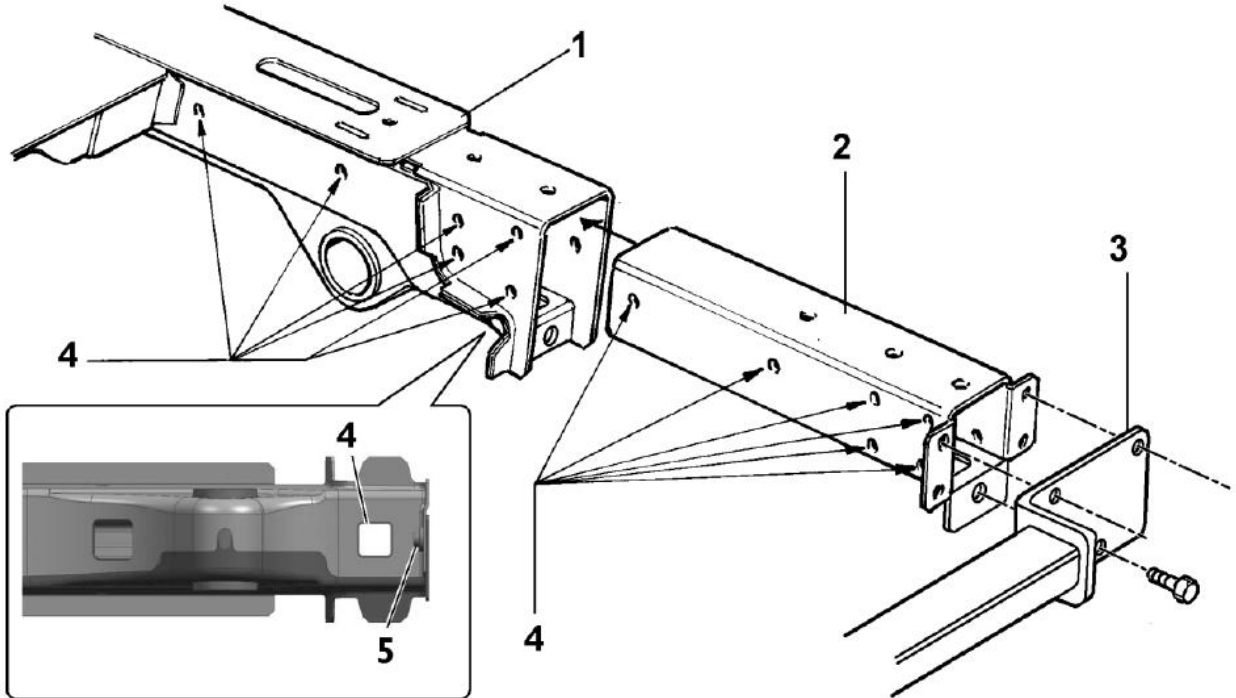

1: structure of the vehicle on which the towing hook transom bar is fastened; 2: tow hook stringer; 3: towing hook attachment flange; 4: holes for fastening assembly to chassis; 5: nut.

Calculation of maximum towable weight after vehicle conversion.

If overhang is lengthened, or the towing hook position changed with respect to the approved position, the towable weight can be calculated by means of the following formula:

$$C_1 = \frac{C_r \times S_n}{S_1}$$

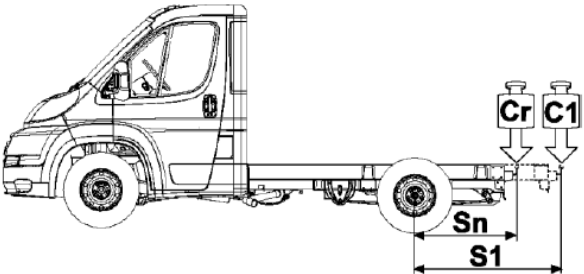

Where: S_1 = Overhang with moved hook
 C_1 = New towable weight
 S_n = Overhang with standard hook

SPARE WHEEL

The spare wheel is positioned in the rear part of the vehicle, in the external compartment under the chassis.

The complete device is fastened to the cross-member (4):

- at the center by the wheel lifting/lowering cylinder (1),
- to the side by the control (3) with cables and brackets (5).

Spare wheel position for chassis cab versions.

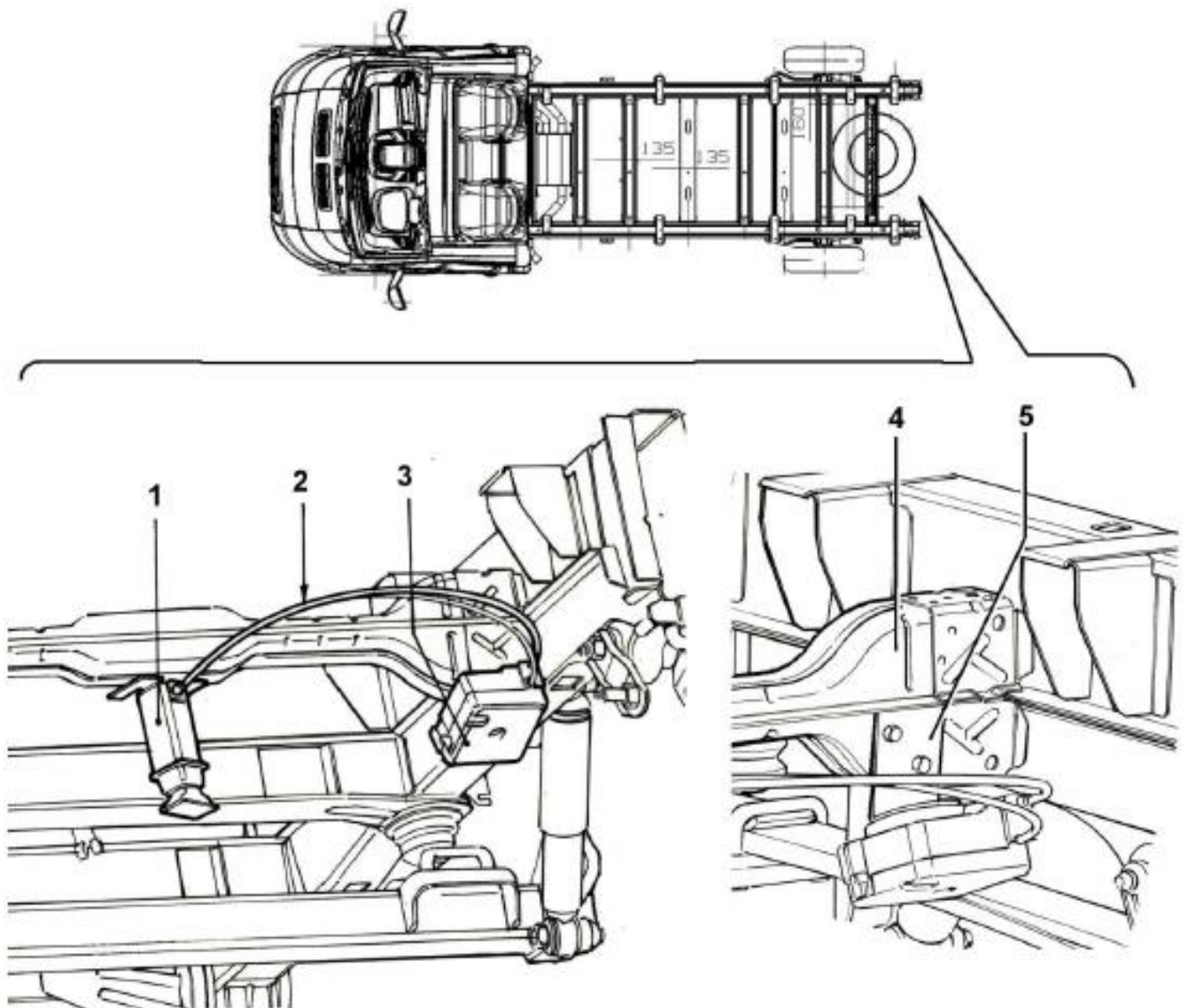

Relocation of spare wheel for chassis cab versions

If the spare wheel mounting (3) and (2) has to be repositioned (for instance for lengthening the overhang, see detail 4), the anchor points must be transferred to the new structure, at the same distances used for its installation on the original vehicle (see drawings on previous page).

In this condition the device will function correctly.

When repositioning, easy access must be maintained not only to the spare wheel, but also to the control must (detail 3 in diagram below).

➤ **NOTE:** restore the wheel upper fastening points by means of two cross members (5).

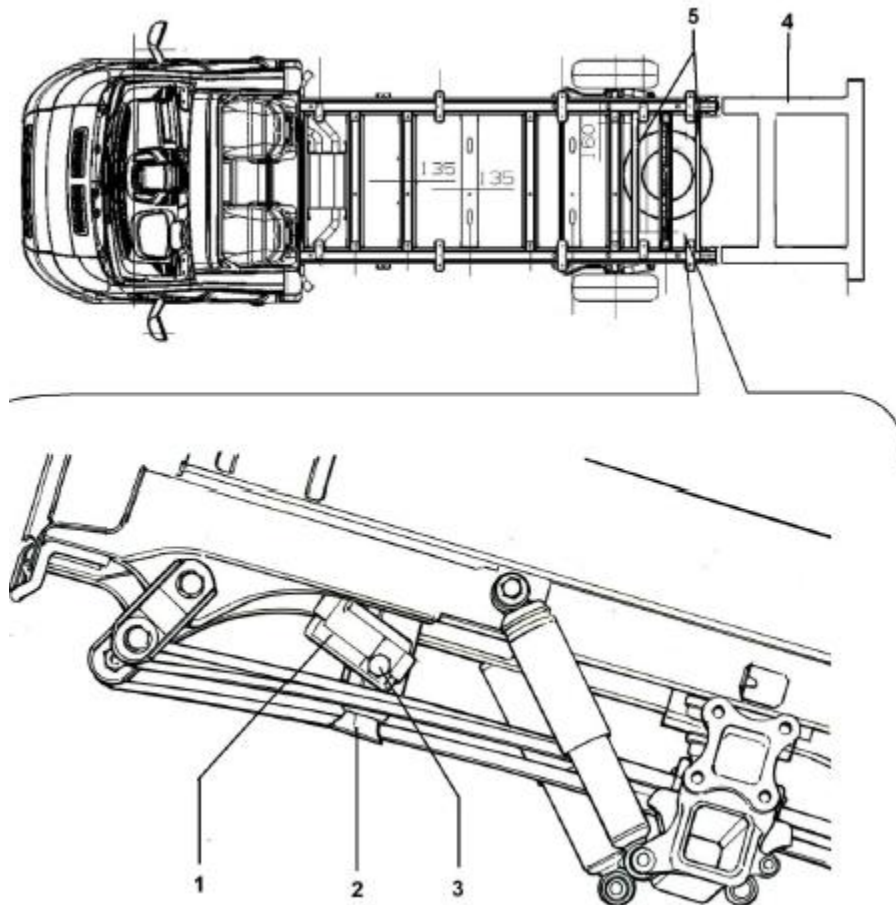

MODIFYING THE CHASSIS

Drilling holes in the chassis

To fit additional assemblies to the chassis or bodyshell, as a general rule existing holes should be used.

If new holes have to be made they should be made on the vertical wall of the longitudinal member and thoroughly de-burred and reamed.

For the drilling, keep to the figure, and :

- under no circumstances should the dimension 'a' be less than 30% of the chassis height (h);
- the distance between adjacent holes must never be less than 50 mm;
- the maximum diameter of the holes must not exceed 12 mm;
- the new holes must not be made near areas under greater stress, such as: areas for spring mountings, shock absorbers, brackets, crossmember attachments.

When necessary, fit spacers in the original structures. Make the weld as shown in the diagram and then apply corrosion protection.

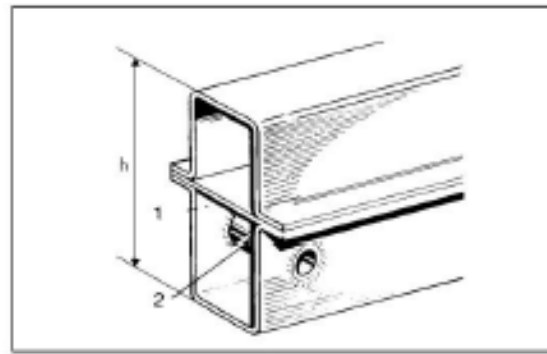
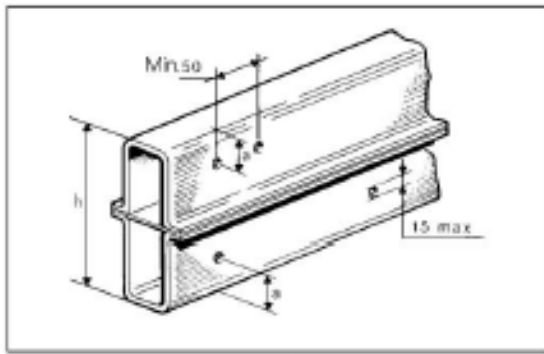

1- Chassis; 2 - Spacer bushing

For chassis cab versions with sub-frame, superstructures can be mounted on the upper longitudinal member present on the basic version (fig. A). For 'special' versions, holes are provided for use as shown in figure (B).

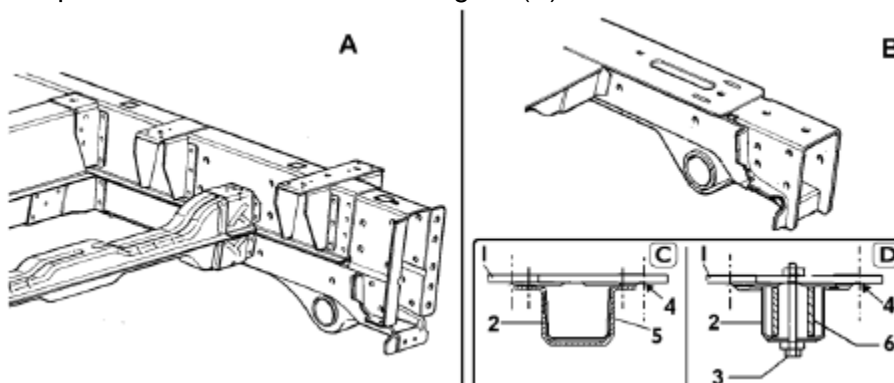

1: upp. plate - 2: longitudinal member - 3: attachment - 4: reinforcing plate - 5: superstructure fastening holes - 6: box-member reinforcing bushing.

C: fastening solution with addition of an external U-bolt. **D:** fastening solution with addition of internal bushing.

ProMaster Chassis Structural Modifications

Applied Body attachment

The purpose of the applied body subframe is to ensure an even distribution of the loads over the vehicle frame and to contribute to the stiffness of the vehicle as a function of its intended job.

For its construction, keep in mind that the material must have good mechanical weldability properties. The elements anchoring the subframe to the vehicle frame must be designed to ensure a stable connection under the effects of longitudinal and lateral loads (due to the loads when cornering and when the brakes are applied). Interpose an elastic block, made of canvas rubber or a similar material with Shore hardness < 70, under the first fastener at the cab end. Interpose rigid spacers under the other connections.

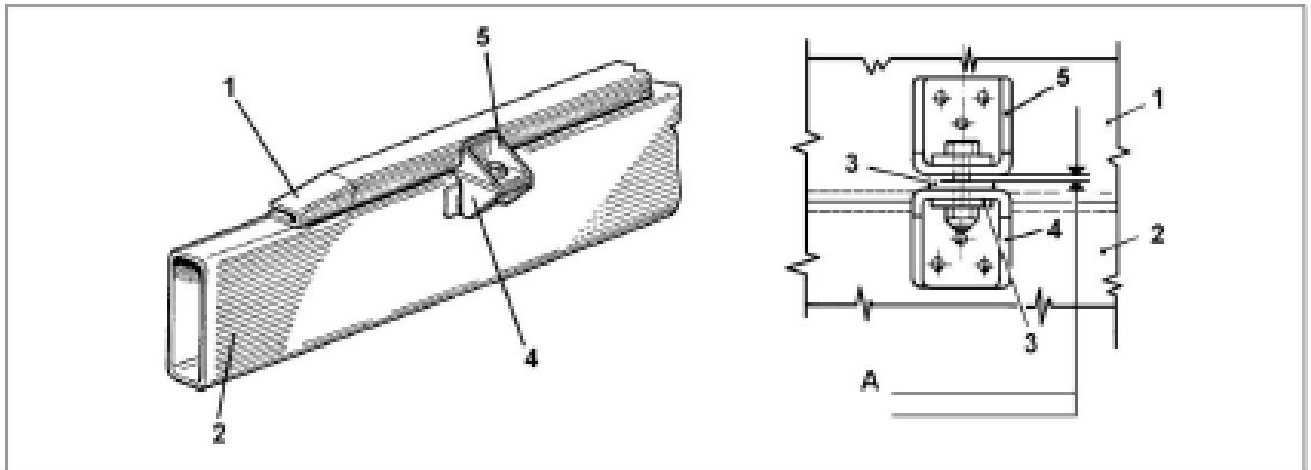

1: subframe; 2: Frame; 3: Spacer; A: Gap between the frames: 4-5 mm. 4: Bracket on frame; 5: Bracket on subframe.

Revisions to Vehicle Wheelbase

Wheelbase changes are allowed chassis-cabs and cutaways only. If you have to change the wheelbase, the length added must never exceed 10% the length of the original wheelbase and, in any event, the final length must never exceed 4035mm. The figure shows a method for the lengthening of the wheelbase. The quantity and the positions of the connections or welds given in the figure are only indicative. The change must always ensure appropriate bending and torsional stiffness of the structure. It is the responsibility of the final stage manufacturer to ensure the compliance and durability of the modified vehicle.

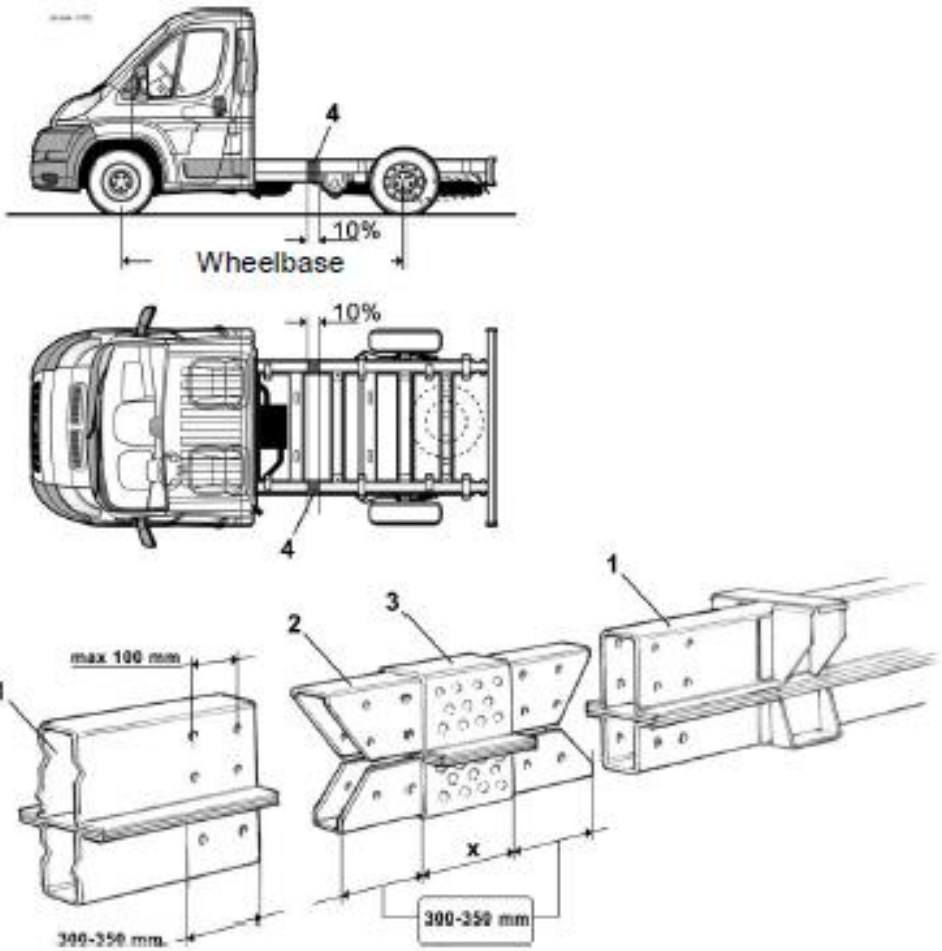

ProMaster Chassis Structural Modifications

1: Original frame; 2: Reinforcing boxed section; 3: Additional frame; 4: Cutting zone for wheelbase modification;
x: wheelbase lengthening variable dimension (max. 10% of original wheelbase length).