

2015 - 2018 Snow Plow Lighting Interface

Overview of Snow Plow Lighting Interface

Traditionally, when installing a snow plow, the vehicle's headlights are disabled in favor of those mounted on the snow plow itself. In order to do this, the snow plow manufacture provides an electrical interface that installs between the OEM headlight harness and the headlight itself. When the plow is installed, the power to the vehicle headlights is re-routed through the snow plow electrical interface to the snow plow headlights. As a result, the vehicle headlights are disabled.

As headlight design becomes more complex with the introduction of new lighting sources, connectors, and even integrated diagnostics; it becomes less and less feasible to install snow plow lights using traditional methods. To counter this, Ram has introduced an industry first wiring interface that provides all the signaling necessary to control the lights of a snow plow without modification of the OEM headlight harnesses.

Starting in the 2015 model year, this interface will be standard on all 2500, 3500, 4500, and 5500 trucks (unavailable on Power Wagon).

Wire Function and Coloring

The snow plow wiring interface has six wires, one for each headlight function, and an enable wire. When battery positive is applied to the enable wire, the vehicle high and low beams will automatically disable and the other 5 snow plow output wires will enable. *The 5 lighting output wires cannot be used to control exterior lighting without a snow plow attached. They are only enabled when the vehicle's headlights are disabled.*

The table below shows the wire information; function, circuit number, size, color and driver or input type of each of the snow plow wires. A driver can either be active high (or high side drive) or active low (low side drive). It's important to pay attention to which type of drive a specific output it as they do vary.

Function	Number	Size	Color	Driver Type
Park Lamp	L177	18 g	WT/BR	Active Low Output
Snow Plow Lighting Enable	L312	18g	BK/VT	Active High Input
Low Beam	L313	18g	BK/LG	Active Low Output
High Beam	L315	18g	BK/LB	Active Low Output
Left Turn	L317	18g	WT/VT	Active High Output
Right Turn	L318	18g	VT/BR	Active High Output

An active high output is switched to battery positive when active and therefore the opposite end of the load (relay coil) must be wired to a ground. In contrast, an active low output is switched to battery negative (ground) when active so the opposite load (relay coil) must be wired to battery positive.

An example of how to wire these outputs can be seen below. However, many snow plow manufactures offer a solution that may differ from the diagram seen below. Always follow the instructions provided with the snow plow when applicable.

EXAMPLE OF POSSIBLE SNOW PLOW LIGHTING CONFIGURATION

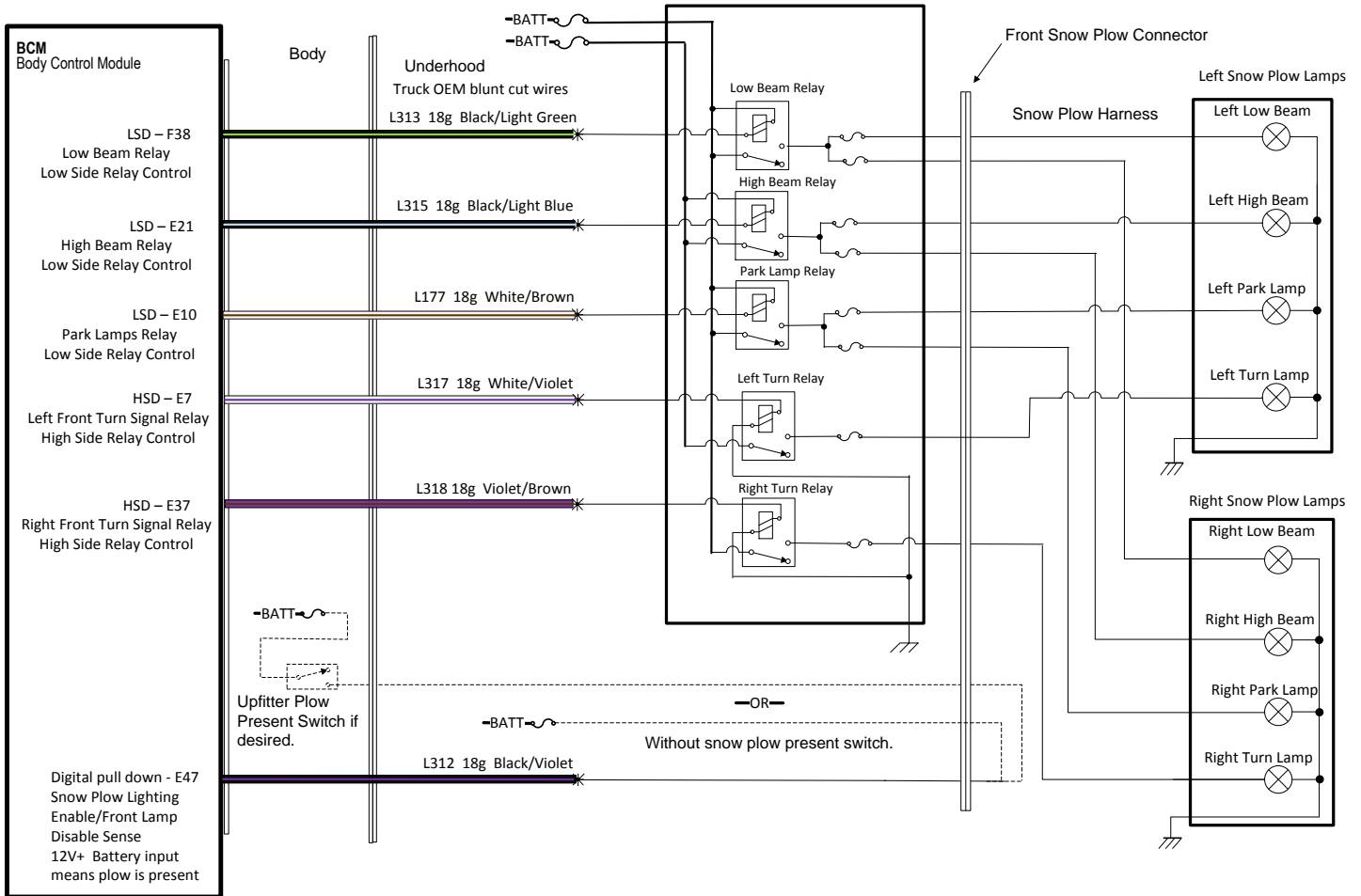

As can be seen in the diagram above, all lighting output drivers are wired directly to a relay. These lighting outputs are intended for driving relays only, and cannot be used to directly drive lights. Each output is rated for 200mA continuous.

Location

The snow plow lighting interface wires can be found under the power distribution center (PDC) which is next to the drive's side wheel well under hood. The PDC can be lifted up by releasing the 4 tabs at each corner of the box.

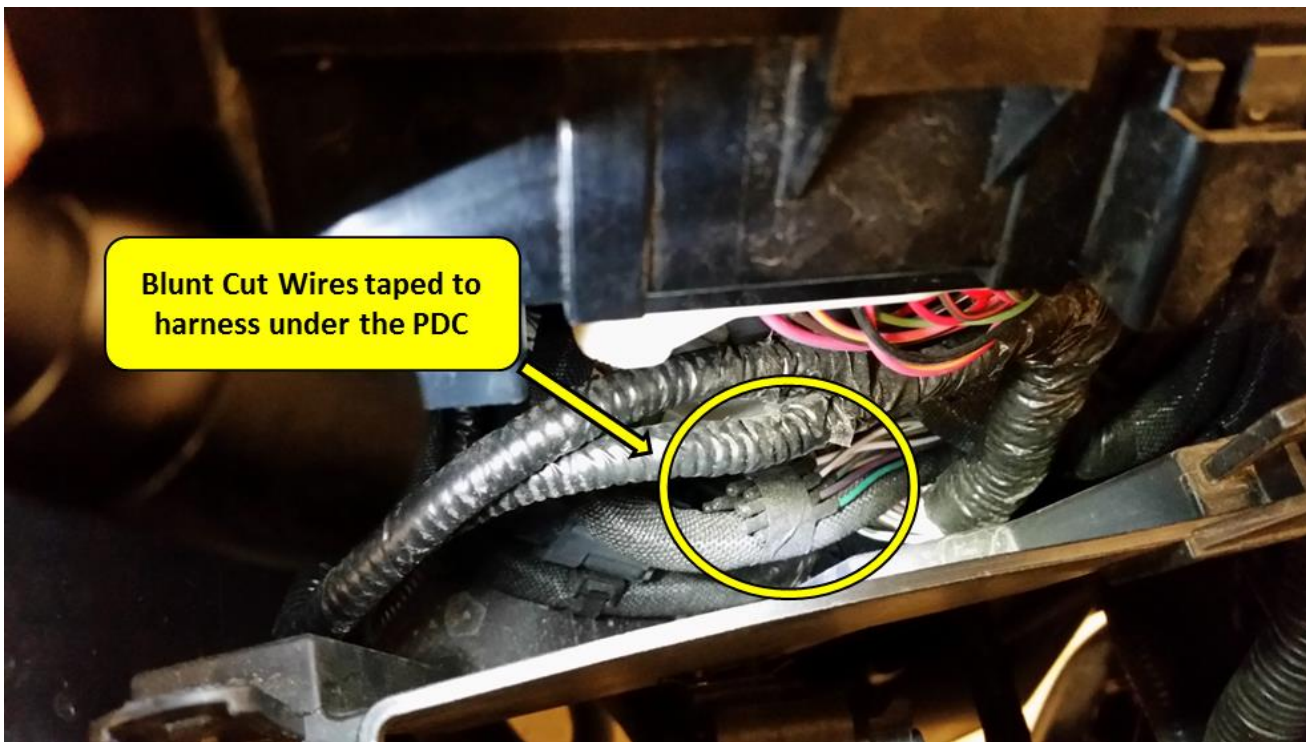
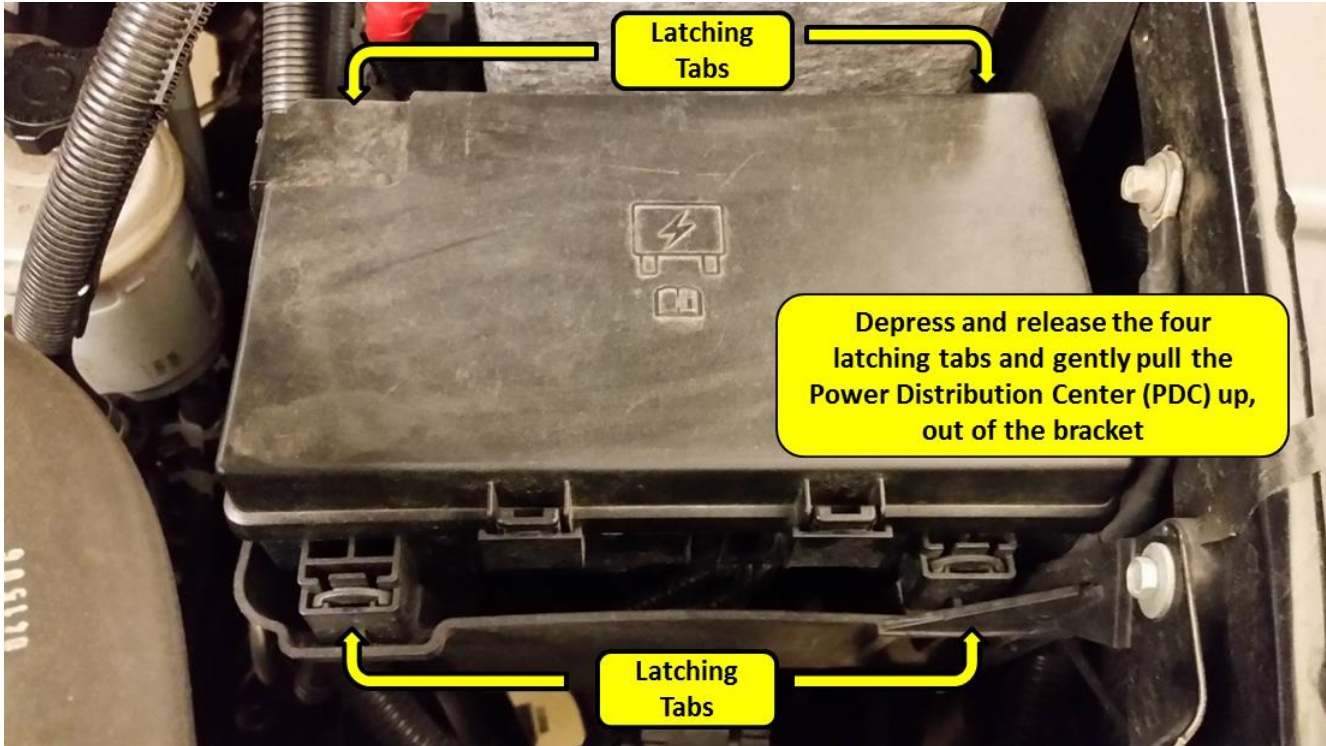

The interface wires can then be seen as blunt cut wires tear taped to another harness.



The interface wires with tear tape removed.

Additional Functionality Notes

When the snow plow present wire is enabled, the vehicle's high and low beams will be disabled and the snow plow interface wires will be enabled. This means that the snow plow lights will now replicate all functionality of the vehicle's headlights when requested (headlights, flash with lock/remote start, ect.). The vehicle's turn signals and park lights will remain active on the vehicle as well becoming active on the plow.

When high beams are requested on with the snow plow attached, the low beam output will remain on as well replicating the existing dual bulb headlight design on Ram trucks. This functionality is often called quad beam because it is intended for headlight designs that have 4 headlights total (2 low and 2 high). If dual filament bulbs are to be used on the plow (total of 2 bulbs used in the headlights), the low beam output should be shut off before the headlight using an external relay or other type of switching device.

For trucks either sold in regions requiring Daytime Running Lamps (DRLs) or where the option was ordered, DRL on functionality was signaled by snow plow low beam relay control active. For 2017 and 2018 the DRL function is Snow Plow Turn Signal Control Active when snow plow enable circuit is active and DRL's are on.

*** Provisions must be made by the plow manufacturer or installer to insure the plow lighting meets governmental requirements.**

Installation Tips

In order to see a state change on the output drivers in the snow plow interface, a minimum load must be placed on the output driver. *Most multimeters will not meet this requirement, and therefore if used alone, only a floating voltage will be seen.* If a relay is not available for testing, a 1K ohm resistor should be used as a load. If switched ignition power is required it is not necessary to use under dash wiring in the cabin to get ignition power. See "Under Hood Switched Battery Circuit" in the "Electrical/Wiring Information" section of the Body Builder's Guide for recommended locations to obtain ignition power.