



**68518618AA**

**FCA US LLC**

800 CHRYSLER DRIVE

AUBURN HILLS, MI 48326-2757

**CAUTION: TRANSPORTATION AND DEALER PERSONNEL — THIS DOCUMENT TO BE REMOVED FROM THE VEHICLE BY THE FINAL STAGE MANUFACTURER ONLY**

***INCOMPLETE VEHICLE DOCUMENT***

**2021 MODEL YEAR RAM PROMASTER VANS**

**THIS DOCUMENT APPLIESTORAMPROMASTERCHASSISCABANDCUTAWAY VAN MODELS**

The purpose of this document is to provide information and direction to subsequent manufacturers who must certify compliance of vehicles manufactured in two or more stages with the United States Federal Motor Vehicle Safety Standards (FMVSS) and the Canada Motor Vehicle Safety Regulations (CMVSS), and other regulations applicable to the USA and/or Canada.

This document is provided in accordance with 49 CFR Part 568 - Vehicles Manufactured in Two or More Stages (National Highway Traffic Safety Administration), and section 6, Regulations Respecting Safety for Motor Vehicles and Motor Vehicle Components under Motor Vehicle Safety Act (Transport Canada).

The statements contained in this Incomplete Vehicle Document are accurate as of the date of manufacture of the Incomplete Vehicle and can be relied on by any intermediate and/or final stage manufacturer as a basis for certification.

**AFFIX FEDERAL OR CANADA INCOMPLETE  
VEHICLE CERTIFICATION LABEL HERE**

Upon completion of this vehicle, the final-stage upfitter, alterer or manufacturer must place a completed Vehicle Tire and Loading Placard on driver's side B-Pillar of the vehicle, as required by CMVSS/FMVSS 110 and/or 120. The sticker below shows the information you will need for the Vehicle Placard.

**AFFIX TIRE LOADING LABEL HERE**

Please consult the Body Builder's Guide at [Ramtrucks.com](http://Ramtrucks.com) for further information.

The following safety standards information is valid only if this vehicle is completed as one of the following vehicle types: **Truck or Multipurpose Passenger Vehicle (MPV).**

No representation as to conformity to any FMVSS or CMVSS beyond the information specifically contained within this document is made.

**Ram ProMaster Chassis Cab and Cutaway Van.**

<p><b>FMVSS 101 CMVSS 101†</b></p>	<p>If this vehicle is equipped with a driver's seat, when completed it will conform with <u>FMVSS 101 - Controls and Displays</u> if no alterations are made to the location, identification or illumination of the controls covered by this standard, including the driver's seating position. Subsequent manufacturers must assure for any controls which are added and covered by this standard.</p>	<p><b>FMVSS 110 CMVSS 110 †</b></p>	<p>The vehicle as shipped does conform to <u>FMVSS 110 - Tire Selection and Rims for Motor Vehicles with GVWR of 10,000 lbs (4,536 kg) or less.</u> If any alterations are made to the vehicle which affect the statements on the label it is the responsibility of the final stage manufacturer to properly amend the Tire and Loading placard label on the vehicle according to FMVSS 110, as well as assure tire, tire rims and tire pressure are appropriately selected for the vehicle.</p>
<p><b>FMVSS 102 CMVSS 102†</b></p>	<p>This vehicle, when completed, will conform to <u>FMVSS 102- Transmission Shift Lever Sequence, Starter Interlock, and Transmission Braking Effect</u> if no alterations are made to the transmission, shift control, accelerator control, or starter interlock system on automatic transmissions, provided that the shift lever positions are permanently displayed in view of the driver.</p>	<p><b>FMVSS 111 CMVSS 111†</b></p>	<p>This vehicle, when completed, will conform to <u>FMVSS 111 - Rear Visibility</u> if no alterations are made to the rearview mirror and camera systems, and the driver's indirect view to the rear is not obscured by the body or other equipment.</p> <p><b>NOTE:</b> The factory supplied loose shipped rear camera must be mounted in such a way that it meets the requirements of <u>FMVSS 111 - Rear Visibility.</u></p>
<p><b>FMVSS 103 CMVSS 103†</b></p>	<p>This vehicle, when completed, will conform to <u>FMVSS 103 - Windshield Defrosting and Defogging Systems</u> if no alterations are made to the defroster system, including vehicle heater assembly and controls.</p>	<p><b>FMVSS 113 CMVSS 113 †</b></p>	<p>This vehicle, when completed, will conform to <u>FMVSS 113 CMVSS 113† - Hood Latch Systems</u> if no alterations are made to the hood latches or attaching parts.</p>
<p><b>FMVSS 104 CMVSS 104†</b></p>	<p>This vehicle, when completed, will conform to <u>FMVSS 104 - Windshield Wiping/Washing Systems</u> if no alterations are made to windshield wiping or washing systems.</p>	<p><b>FMVSS 114 CMVSS 114†</b></p>	<p>This vehicle, when completed, will comply with <u>FMVSS 114 - Theft Protection</u> if no alterations are made to the steering column lock, transmission shift linkage, ignition switch interlock or the audible key-left-in-lock warning systems.</p>
<p><b>FMVSS 105 CMVSS 105†</b></p>	<p>This vehicle, when completed, will comply with <u>FMVSS 105 - Hydraulic Brake Systems</u> if:</p> <ul style="list-style-type: none"> <li>• No alterations are made to the service and parking brake systems, wheels, tires, or suspension.</li> <li>• Rear axle must carry at least 37 percent of the vehicle weight when the front seat is ballasted to 400 lbs.</li> <li>• The GVWR and GAWR are not exceeded.</li> <li>• The front axle curb weight of the completed vehicle may not be reduced by no more than 10%, using the front axle ground reaction as manufactured by FCA US LLC.</li> <li>• For the Ram ProMaster Chassis Cabs and Cutaways, the height above frame rail datum line of the combined centers of gravity of components added by the subsequent manufacturer does not exceed Ymax, where ... Ymax=B- 1.6(X)</li> </ul> <p><b>NOTE:</b> If the combined CG of the added components is behind the rear axle, then Ymax = B+1.6x. X = horizontal distance in inches from the centerline of the rear axle to the combined center of gravity of all the added items. MINUS (-) is forward and PLUS (+) is rearward of rear axle centerline B = factors (see chart at end of this document)</p>	<p><b>49 CFR Part 565 CMVSS 115 †</b></p>	<p>This vehicle, when completed, will conform to <u>49 CFR Part 565 or CMVSS 115 - Vehicle Identification Number</u> if:</p> <ul style="list-style-type: none"> <li>• No alterations are made to the VIN plate, the VIN plate-mounting, or the VIN plate location.</li> <li>• No component installed by the subsequent manufacturers obscures the visibility of the VIN plate through the windshield.</li> </ul>
<p><b>FMVSS 106 CMVSS 106 †</b></p>	<p>This vehicle, when completed, will conform to <u>FMVSS 106 - Brake Hoses</u> if no alterations are made to the hydraulic or vacuum brake hose assemblies.</p>	<p><b>FMVSS 116 CMVSS 116†</b></p>	<p>This vehicle, when completed, will conform to <u>FMVSS 116 CMVSS 116† - Motor Vehicle Brake Fluids</u> if no alterations, substitutions, or introduction of foreign material are made to the brake fluid.</p>
<p><b>FMVSS 108 CMVSS 108† CMVSS 108.1†</b></p>	<p>Chassis Cab and Cut Away vehicles will not conform to <u>FMVSS 108 - Lamps, Reflective Devices and Associated Equipment</u> in its present (incomplete) stage of manufacture. All incomplete vehicle manufacturer-installed components which are covered by this standard will comply, provided that subsequent manufacturers do not alter, obscure, or relocate these components. Subsequent manufacturers must add all necessary additional equipment required to meet this standard.</p>	<p><b>FMVSS 118 CMVSS 118†</b></p>	<p>If so equipped, this vehicle, when completed, will conform to <u>FMVSS 118 - Power Operated Window, Partition and Roof Panel Systems</u> if no alterations are made to the power window and related electrical systems. Subsequent manufacturers must assure compliance with <u>FMVSS 118 - Power Operated Window, Partition and Roof Panel Systems</u> if powered roof panels, internal partitions or power operated rear window systems are installed.</p>
<p><b>FMVSS 124 CMVSS 124†</b></p>	<p>This vehicle, when completed, will conform to <u>FMVSS 124 - Accelerator Control Systems</u> if no alterations are made to the accelerator control system.</p>	<p><b>FMVSS 126 CMVSS 126†</b></p>	<p>This vehicle when completed will conform to <u>FMVSS 126 - Electronic Stability Control Systems</u> if no alterations are made to the stability control system, chassis and/or electrical components.</p>
<p><b>FMVSS 138</b></p>	<p>This vehicle when completed will conform to <u>FMVSS 138- Tire Pressure Monitoring Systems</u> if no alterations are made to the tire pressure monitoring system or related chassis and/or electrical components.</p>	<p><b>FMVSS 139 CMVSS 139†</b></p>	<p>This vehicle when completed will conform to <u>FMVSS 139 - New Pneumatic Radial Tires for Light Vehicles</u> if no alterations are made to the radial tires or related chassis components.</p>

\*If so Equipped. (†) See Section on Canadian Regulations. (&) sections as applicable

**FMVSS 201  
CMVSS 201†**

If this vehicle is equipped with a factory seat or seats, when completed, will conform to FMVSS 201 - Occupant Protection in Interior Impact if no alterations are made to the seat locations, instrument panel, armrests, the interior trim including but not limited to, the upper interior trim including that over the doors, windshield and rear window, the roof side rails, the headliner, headliner and roof mounted components, and roof pillars.

Subsequent manufacturers must assure compliance for any added designated seating positions and for any modifications that may alter the crash characteristics, performance, or pulse, including, but not limited to, crash sensors and airbag deployment electronics, occupant restraint system including the seat belt system and airbags.

**FMVSS 202  
FMVSS 202a  
CMVSS 202†  
CMVSS 203†**

This vehicle, when completed, will conform to FMVSS 202a - Head Restraints if no alterations are made to the seat(s) or head restraints.

This vehicle when completed, will conform to FMVSS 203 - Impact Protection for the driver from the Steering Control System if no alterations are made to the driver's seat location, steering wheel, steering column assembly or any attaching parts.

**FMVSS 204  
CMVSS 204†**

This vehicle, when completed, will conform to FMVSS 204 Steering Control Rearward Displacement\* if:

- No alterations are made to the steering control system, including, but not limited to, steering wheel, steering column assembly, front structure, bumper and attaching parts.
- When tested in accordance with the requirements of the standard; (1), no component installed by the subsequent manufacturer impinges upon the steering control system with the sufficient energy to displace the steering control systems, and (2), no vehicle modification by the subsequent manufacturer results in any portion of the vehicle impinging upon the steering control system with sufficient energy to displace the steering control system.

**NOTE:** FMVSS 204 is applicable only if completed vehicle has an unloaded vehicle weight of 5,500 lbs or less.

**FMVSS 205  
CMVSS 205†**

This vehicle, when completed, will conform to FMVSS 205- Glazing Materials if no alterations are made to the windshield or windows, and if no nonconforming glazing materials are added.

**FMVSS 206  
CMVSS 206†**

This vehicle, when completed, will conform to FMVSS 206- Door Locks and Door Retention Components if no alterations are made to the door locks, door hinges or their attachments.

**FMVSS 207  
CMVSS 207†**

If this vehicle is equipped with (factory) driver's seat or front seats, -when completed, it will conform to FMVSS 207 Seating Systems if no alterations are made to the seats, seat tracks, vehicle underbody including, but not limited to frame, body, body mounts, or any attaching parts.

Subsequent manufacturers must assure compliance for any added designated seating positions and for any modifications that may alter the crash characteristics, performance, or pulse, including, but not limited to, crash sensors and airbag deployment electronics, occupant restraint system including the seat belt system and airbags.

**FMVSS 208  
CMVSS 208†**

If this vehicle, when completed, will conform to FMVSS 208- Occupant Crash Protection if no alterations are made to the factory seat belt and seat belt warning systems, factory seat locations and/or the windshield header.

Subsequent manufacturers must assure compliance for any added designated seating positions and for any modifications that may alter the crash characteristics, performance, or pulse, including, but not limited to, crash sensors and airbag deployment electronics, occupant restraint system including the seat belt system and airbags.

**FMVSS 209  
CMVSS 209†**

This vehicle, when completed, will conform to FMVSS 209 - Seat Belt Assemblies if no alterations are made to the factory seat belt assemblies. Subsequent manufacturers must assure compliance for added designated seating positions.

**FMVSS 210  
CMVSS 210†**

This vehicle, when completed, will conform to FMVSS 210 - Seat Belt Assembly Anchorages if no alterations are made to the factory seat belt assembly anchorages, body parts, frame, body mounts, or seat location. Subsequent manufacturers must assure compliance for added designated seating positions.

**FMVSS 212  
CMVSS 212†**

This vehicle, when completed, will conform to FMVSS 212 - Windshield Mounting if:

- No alterations are made to the body, body mounts, and frame rails that significantly affect crush from back of the cab forward in the vehicle.
- No alterations are made to the windshield or the windshield mounting system.
- When tested in accordance with the requirements of this standard: (1), no component installed by the subsequent manufacturers impinges upon the cab with sufficient energy to separate the windshield from its mounting, and (2), no vehicle modification by the subsequent manufacturer results in any portion of the vehicle impinging upon the cab with sufficient energy to separate the windshield from its mounting.

**FMVSS 214  
CMVSS 214†**

This vehicle, when completed, will meet FMVSS 214 - Side Impact Protection. This applies if no alterations are made to the vehicle, including but not limited to the seat belt and seat belt warning systems, seat locations, headliner assembly, doors, door frames, door latches, door hinges or attaching parts, vehicle structure below the doors and the door aperture structure.

Subsequent manufacturers must assure compliance for any added designated seating positions and for any modifications that may alter the crash characteristics, performance, or pulse, including, but not limited to, crash sensors and airbag deployment electronics, occupant restraint system including the seat belt system and airbags.

**FMVSS 216a  
CMVSS 216†**

This vehicle, when completed, will conform to FMVSS 216a - Roof Crush Resistance, if no alterations are made to the roof panel or its support structure, including the roof rails, front header, roof pillars, the door window frames, the windshield and the windshield mounting system.

\*If so Equipped. (†) See Section on Canadian Regulations. (&) sections as applicable

**FMVSS 219  
CMVSS 219†**

This vehicle, when completed, will conform to FMVSS 219- Windshield Zone Intrusion if:

- No alterations are made to the hood mounting system, the body & vehicle structure that would alter vehicle crush from just behind the front seats forward in the vehicle.
- When tested in accordance with the requirements of this standard: (1), no component installed by the subsequent manufacturer penetrates the “protected zone” of the windshield or the inner surface of that portion of the windshield below the “protected zone” and (2), no vehicle modification by the subsequent manufacturer results in any portion of the vehicle penetrating the “protected zone” of the windshield or the inner surface of that portion of the windshield below the “protected zone”.

**FMVSS 225  
CMVSS 210.1†  
And CMVSS 210.2†**

This vehicle, when completed, will conform to FMVSS 225- Child Restraint Anchorage Systems (USA) or CMVSS210.1 and 210.2 - Tether Anchorage for Child Restraints if no alterations are made to child seat top anchorages, body parts or seat locations. Subsequent manufacturers must assume compliance for added designated seating positions.

**FMVSS 226  
CMVSS 226†\***

This vehicle, when completed, will conform to FMVSS 226 - Ejection Mitigation if no alterations are made to the seat belt, seat locations, roof rail, A-pillar/B-pillar upper, and/or windshield header. Subsequent manufacturers must assure compliance for any modifications to the vehicle side structure that may alter the crash characteristics, performance, or pulse, including, but not limited to rails or attaching parts, crash sensors and side air bag curtain deployment electronics.

**FMVSS 301  
CMVSS 301†**

This vehicle, when completed, will conform to FMVSS 301 - Fuel System Integrity if:

- No alterations are made to the fuel system.
- The Unloaded Vehicle Weight (UVW) Of the completed vehicle does not exceed the values listed in the next table.
- When tested in accordance with the requirements of this standard, no component installed by the subsequent manufacturer impinges upon the fuel system with sufficient energy to puncture or separate the fuel system, and no vehicle modification by the subsequent manufacturer results in any portion of the vehicle impinging upon the fuel system with sufficient energy to puncture or separate the fuel system.

**Ram ProMaster Models GVWR Max Unloaded Vehicle Weight (UVW)**

Model	Body	WB	Engine	GVWR	UVW
3500	Chassis Cab/ Cutaway	136	3.6L Gas	9,350	7,105
3500	Chassis Cab/ Cutaway	159	3.6L Gas	9,350	7,127
3500	Chassis Cab/ Cutaway	159 Ext	3.6L Gas	9,350	7,160

**FMVSS 302  
CMVSS 302†** This vehicle, when completed, will conform to FMVSS 302 - Flammability of Interior Materials if no alterations are made to any interior component and no non-conforming interior materials are added.

\*If so Equipped. (†) See Section on Canadian Regulations. (&) sections as applicable

**Canadian Requirements**

This incomplete vehicle as produced by FCA US LLC conforms in full with the Canadian Motor Vehicle Safety Regulations indicated by (†) in the listing throughout this document except as noted for CMVSS 108 and 111. In addition, this incomplete vehicle also conforms to Canadian Motor Vehicle Safety Regulation (CMVSS) 1106 - Interior and Exterior Noise and, when completed, will continue to comply if no alterations are made to the air intake system, cooling system, exhaust system or tires, and no obstructions are placed in close proximity to the tail pipe outlet.

Further, this incomplete vehicle, as manufactured by FCA US LLC, fully complied with Interference-Causing Equipment Standard ICES-002, and when completed will continue to comply if no alterations are made to the distributor, ignition coils, ignition wires, spark plug wires, spark plugs or spark plug sleeves.

**Other Federal Requirements**

**NOTE:**

**Intermediate Manufacturers**

Each intermediate manufacturer making any changes in this vehicle which affect the validity of any statement in this document as provided to him must furnish an addendum to this document that contains his name, mailing address and an indication of all changes that should be made in this document to reflect changes that he made in this vehicle. The incomplete vehicle manufacturer must then furnish this document, along with any addenda, as required, and in the manner specified in Paragraph 568.5 of Part 568 of Title 49 CFR Part 568.

**NOTE:**

**Final Manufacturers**

The final-stage manufacturer must complete this vehicle in such a manner that it conforms to all standards in effect on the date of manufacture by FCA US LLC, the date of final completion, or a date between those two

dates. The final-stage manufacturer must certify the completed vehicle as required by sections 567.5 and 568.6, 49 CFR Part 567 and 568.

**Sample Calculation – Ram ProMaster FMVSS/CMVSS† 105 Compliance, Chassis Cab / Cutaway**

**Example:**

Subsequent manufacturer wishes to add a 61.5-lb Hitch to the Rear bumper and a 1,110-lb body to a 136" wheelbase RAM 3500 ProMaster chassis cab. The midpoint of the hitch will be 30" from the centerline of the rear axle directly above the frame rails. The body will be placed directly behind the cab and its floor will be directly above the frame rails. Can the modification be done without negating FMVSS/CMVSS† 105 compliance?

**Solution:**

First, determine the location of the center of gravity of the individual components to be added. For the purposes of this example, the center of gravity (CG) of the Hitch is 5 inches above its base and at its exact center in the fore and aft direction. The CG of the body is 7.5 inches above its floor and 63.2 inches from its front in the fore and aft direction. (See illustration on next page). This corresponds to 17.9" in front of the rear axle.

Second, calculate the combined CG of the hitch and body in the fore and aft direction. To find the combined CG, the weight of the hitch is multiplied by the distance of its CG from the centerline of the rear axle. This result is then divided by the total weight of the components.

$$X = \frac{(-17.9" \times 1,110 \text{ lb}) + (30" \times 61.5 \text{ lb})}{(1,110 \text{ lb} + 61.5 \text{ lb})} = -15.4"$$

A negative value for "X" indicates that the CG is in front of the rear axle centerline.

**NOTE:** If all added component CGs are behind the rear axle, then the respective weight times CG distance results are added together before being divided by total weight.

Third, calculate Ymax from the equation: Ymax = B+1.6(X).

From the Truck "B" factor table, "B" for a 1,171-lb load for a 136-inch wheelbase is about 90.

Therefore,  $Y_{max} = 90 + 1.6(-15.4) = 65.4$  inches.

Fourth, calculate the combined vertical CG of the added components (Y) by multiplying the CG height of each component by the weight of each component, adding the results and dividing by the total weight of components:

$$Y = \frac{5'' \times 61.5 \text{ lb} + 7.5'' \times 1,110 \text{ lb}}{(61.5 \text{ lb} + 1,110 \text{ lb})} = 7.36''$$

**NOTE:**

If an added component's CG was below the frame rail datum line, then its weight-times-CG-distance result would be subtracted from the weight-times-distance-result of components with CGs above the frame rail datum line.

Fifth, compare the value of Y with  $Y_{max}$ . For the additional components to be installed without affecting FMVSS/ CMVSS† 105 compliance, the value of Y must not exceed  $Y_{max}$ . In the above example,  $Y(7.36'')$  is less than  $Y_{max} (65.4'')$ . Therefore, the hitch and body combination can be added.

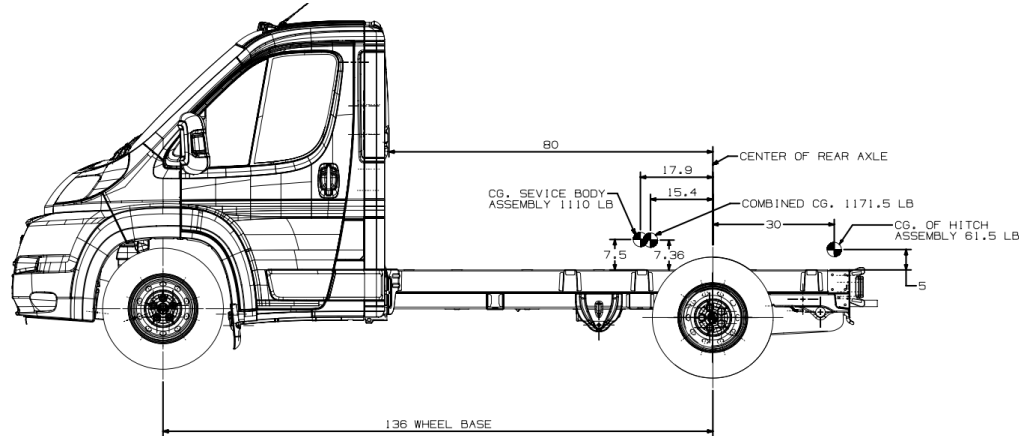

**INCOMPLETE VEHICLE AND HEAVY-DUTY ENGINE INFORMATION INCOMPLETE VEHICLES  
FEDERAL, CANADA AND CALIFORNIA (AND STATES ADOPTING CALIFORNIA EMISSION REGULATIONS)**

**EXHAUST EMISSION CERTIFICATION PARAMETERS – INCOMPLETE VEHICLE – BOX OFF PACKAGES**

The gasoline powered trucks listed below will conform with all Federal, Canadian or the State of California (and states adopting California emission requirements) exhaust emission regulations applicable to the 2019MY new heavy-duty vehicles and medium duty vehicles, if the following conditions are not exceeded in completion of the vehicle.

MODELS Incomplete Vehicles - Box Off Pkgs.	Body Model	Engine Displacement	Sales Area	GVWR	Max Completed Truck Curb Weight	Max Completed Truck Curb Frontal Area
Cab Chassis / Cutaway	VF	3.6 L Gasoline	Federal, Canada and California	*	*	*

See under hood Vehicle Emission Control Information (VECI) label or consult the Weight Chart Tables at [www.Ramtrucks.com](http://www.Ramtrucks.com).

**FOR GASOLINE FUELED INCOMPLETE VEHICLES**

**FUEL VAPOR RECOVERY (GASOLINE FUELED VEHICLES) – CALIFORNIA, AND STATES ADOPTING CALIFORNIA EMISSION REQUIREMENTS**

The following information applies to gasoline fueled vehicles for sale or use in the states of California and states adopting California emission requirements. California regulations require that the vehicle fuel systems be designed to accommodate a vapor recovery fueling nozzle including unobstructed access to the fill pipe. Fuel filler pipes installed according to the instructions provided in the fuel filler kit will comply with the "Specifications for Fill Pipes and Openings of Motor Vehicle Fuel Tanks," referenced in Title 13 California Administrative Code providing no part of the second body, as installed, intrudes into the nozzle access zone.

**ADDITIONAL MODIFICATION INFORMATION FOR FEDERAL, CANADA AND CALIFORNIA, AND STATES ADOPTING CALIFORNIA EMISSION REQUIREMENTS**

The term "second bodies" includes not only the basic body or body structure but also any equipment permanently attached to the vehicle installed by the vehicle alterer.

- None of the following fuel system components as installed by FCA US LLC are to be removed, replaced, relocated, altered or modified in any way:
  - Fuel tank and attachment hardware, including sending unit and vapor valve
  - Fuel lines, routing and attachments, excluding fuel filler cap, filler pipe, filler hose and filler system attachment hardware
  - Vapor line and carbon canister
  - Fuel pump
  - Leak detection system
  - Fuel filter and attachment
  - Throttle body
  - Air cleaner assembly
- No additional fuel tanks may be added.

- Any alteration or modification made to the vehicle as manufactured by FCA US LLC, and components or structure installed by the vehicle alterer must not result in penetration, separation or other damage to the fuel system or any portion thereof when the vehicle is tested in any manner specified by applicable provisions of FMVSS/CMVSR 301.
- The second body installed and the required fuel system components (identified below) must be located and mounted as follows:
  - Second body components must not contact any fuel system component (other than at the points where the fuel system is permanently attached to the second body)
  - Second body deformation or movement relative to the frame must not cause any fuel system component to be penetrated, disconnected or otherwise damaged
  - The rear end of the second body (excluding the rear bumper) installed must not extend beyond (overhang) the rear edge of the vehicle frame or frame extension. Any extension of the vehicle frame must be constructed and attached so as to perform as a continuation of the vehicle frame when the altered vehicle is tested in any manner specified by applicable provisions of FMVSS/CMVSR 301
  - The fuel filler cap, filler pipe, filler hose and filler system attachment hardware must be installed according to the instructions provided in fuel filler kit and must be securely retained to remain intact when the vehicle is tested in any manner specified by applicable provisions of FMVSS/CMVSR 301

Weight of Components Added by Subsequent Manufacturer [lbs]	B FACTOR		
	Model	Model	Model
	Chassis Cab 136	Chassis Cab 159	Chassis Cab 159 Ext Body
500	100	135	135
1000	95	130	130
1500	90	125	125
2000	85	120	120
2500	80	115	115
3000	75	110	110
3500	70	105	105
4000	65	100	100
4500	60	95	95

**NOTE:**

Extreme permissible positions of center of gravity

**Y-axis:** Never exceed the maximum side to side difference of the laden/unladen vehicle of 4%. **Do not exceed the maximum permissible wheel or axle loads.**

**Center of gravity heights with ESC  
Gross Vehicle Weight Rating (GVWR)  
8900 lbs  
9350 lbs**

**Center of gravity heights, z-axis  
40.6"  
43.7"**