

Door Lock/Unlock input control

Method A - Vehicles with a Vehicle System Interface Module (VSIM)

The VSIM is standard on Cab Chassis starting in 2019. On Pick Up trucks the VSIM is optional (sales code XXS).

Starting in 2019 the Vehicle System Interface Module (VSIM) has door lock and unlock inputs. These circuits when grounded will lock or unlock the vehicle as well as operate the VSIM Lock and Unlock relay control circuits. We suggest using the VSIM lock and unlock command circuits to operate the locks from an outside/added switch.

The Door Lock request input is in pin 4 of the VSIM brown connector circuit W686 Tan/Dark Green wire. The Door Unlock request is in pin 5 of the VSIM brown connector circuit W687 Tan/Light Blue wire. Switching the W686 circuit to ground will lock the vehicle doors and also cause the VSIM door lock relay control output to function. Switching the W687 circuit to ground will cause the vehicle doors to unlock and the VSIM door unlock relay control to function. For additional information and instructions please see the VSIM document in the Body Builders Guide for 2019.

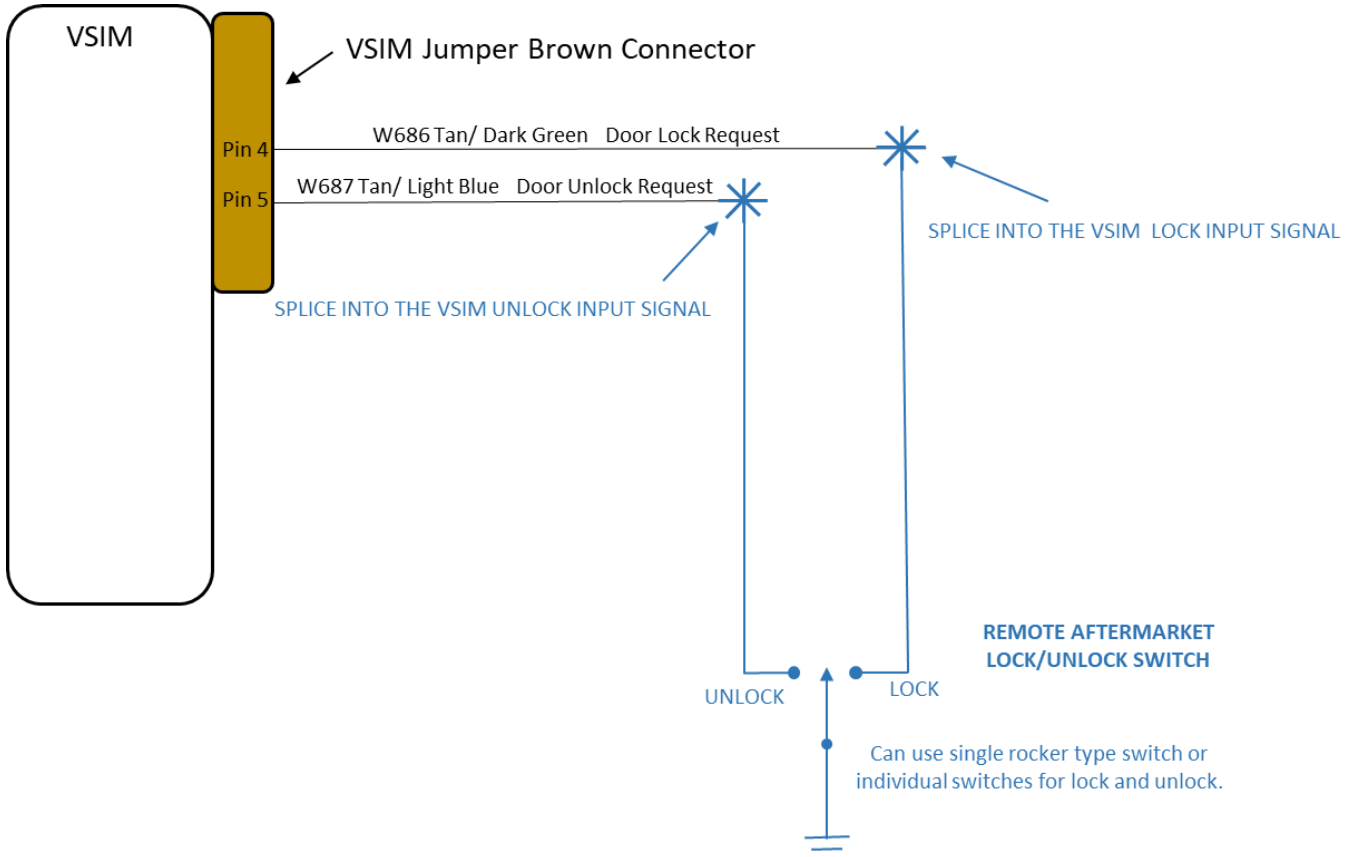

Ram Heavy Duty & Cab Chassis Remote Door Lock Control 2019+

Door Lock/Unlock input control

Method B - Vehicles without a Vehicle System Interface Module (VSIM)

A remote door lock/unlock switch may be installed on a Ram truck that is equipped with power locks. This is done by splicing in to the lock switch circuit in the front passenger door of a four door vehicle or the passenger door of a two door vehicle. (see schematic on next page) There are differences in the electrical/electronic systems between the driver and passenger doors that make it impossible to add the remote lock circuit to the driver's door.

The passenger door module receives a voltage level through a resistor multiplex (built in to the passenger door lock switch) when lock/unlock switch is actuated. Based on the level of that voltage, the door module communicates to the body controller to lock or unlock the doors. To access the circuits and route the wires, the passenger door trim panel must be removed. Route the added single lock switch wire through the wiring boot into the passenger door.

Splice this wire to the G160 circuit (Violet/Light Green) near the switch connector that was removed earlier in this procedure. For a single switch that provides lock and unlock function, one momentary SPDT switch can be used (shown in the drawing below). A system requiring only lock or unlock function could use a single momentary SPST switch controlling only the lock or unlock function. The resistor values to simulate the passenger door lock/unlock switch are, 100 ohm resistor for unlock or a 330 ohm resistor for lock. The resistor should be rated at ½ watt minimum, +/- 5% tolerance.

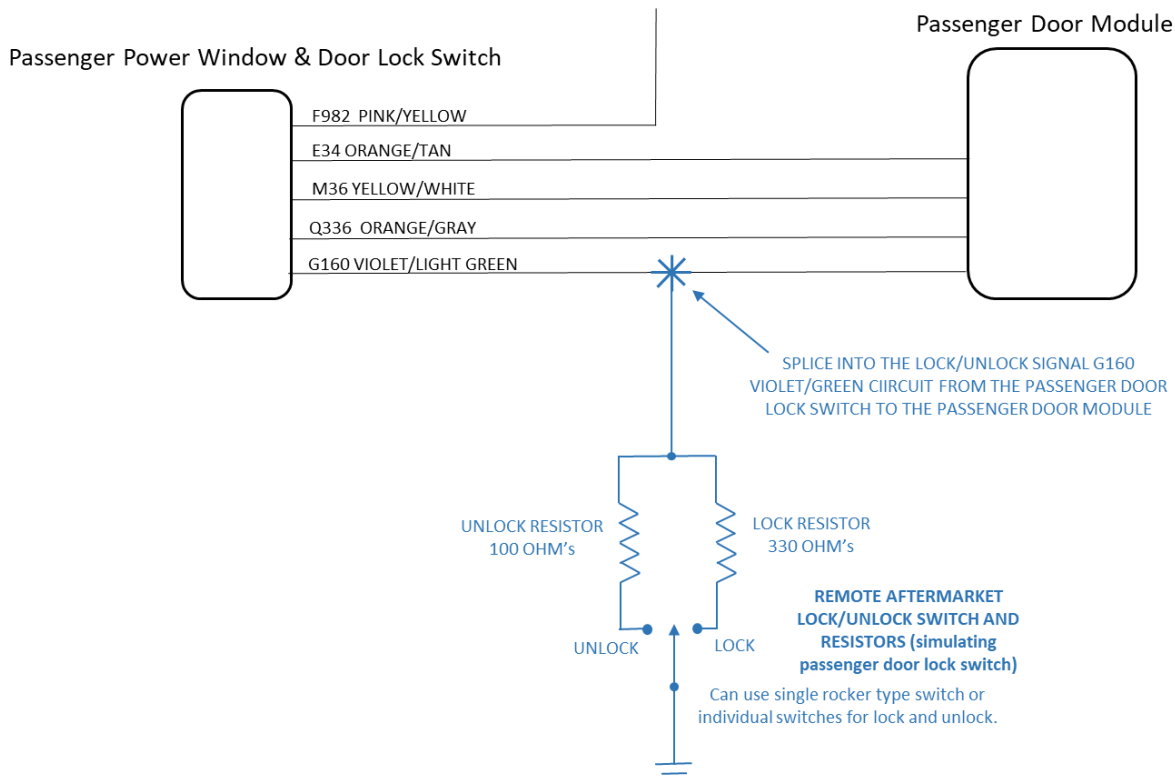

Ram Heavy Duty & Cab Chassis Remote Door Lock Control 2019+

Upfitter added door lock motors with a VSIM

The VSIM has door lock and unlock relay control outputs that can be used to control added lock and unlock relays for additional lock and unlock motors. These outputs will operate when the vehicle door locks operate either through the remote key fobs, vehicle door lock switches or the VSIM door lock/unlock inputs are operated. A sample circuit is below.

VSIM Unlock Relay Driver Output – Is a low side relay control capable of driving a relay coil of up to 0.5 Amps. This unlock relay driver mirrors vehicle unlock “All” request with a ground potential for 500ms. The vehicle need not be awake. Driver Door only unlock request will not activate this output, only an unlock all request will activate the output regardless of the personalization setting. If the Key Fob is used to unlock the doors the unlock button must be pressed twice to activate this output. The VSIM unlock output is in the Brown VSIM Jumper Connector circuit W721 Light Green wire with Beige tracer.

VSIM Lock Relay Driver Output – Is a low side relay control capable of driving a relay coil of up to 0.5 Amps. This lock relay driver, mirrors vehicle lock request with a ground potential for 500ms. The vehicle need not be awake. The VSIM lock output is in the Brown VSIM Jumper Connector circuit W722 Dark Green wire with Tan tracer.

Upfitter added door lock motors with VSIM controlled lock/unlock relays

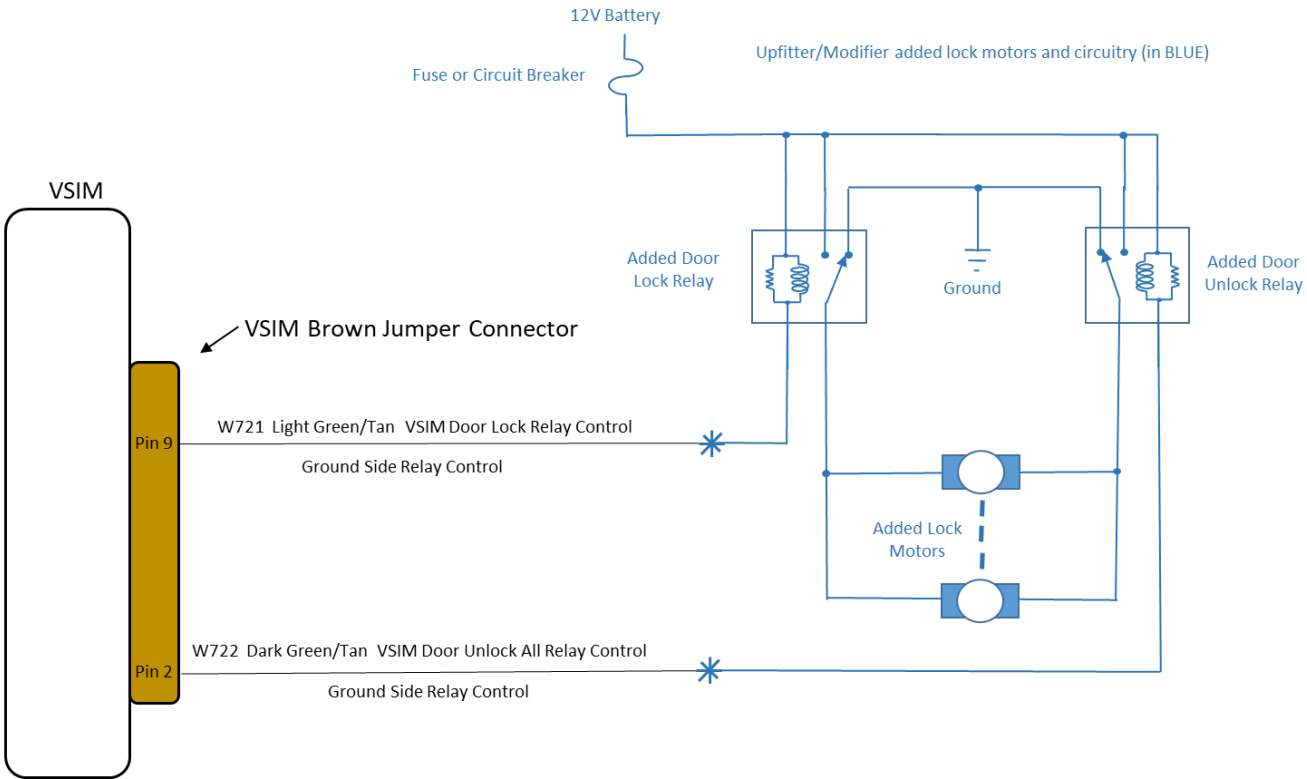

Ram Heavy Duty & Cab Chassis Remote Door Lock Control 2019+

Upfitter added door lock motors on vehicles without a VSIM

If the vehicle is not equipped with VSIM, there is a method to add additional lock/unlock motor control for additional added locks. This is accomplished by tying a pair of diode isolated SPDT relays into the truck's lock motor drive circuits and driving the service body's lock motors with the relays. (see schematic on next page). The vehicle's door locks are controlled by the CBC. The CBC will send a 350mSec pulse to the door lock motors. The polarity of that pulse determines lock or unlock. The CBC controls the "driver's unlock" function separately from the unlock function of the other doors in the vehicle. This is to support the "driver's door only on first press" vehicle feature. There are three lock motor control circuits in the vehicle. P777 is the "all lock" circuit. P910 is the "driver's door" unlock circuit and P292 is the "passenger and rear" unlock circuit. This procedure utilizes the "all lock" and "passenger and rear door" unlock circuits. Blocking diodes must be placed in series with the relay coils. This is to prevent the unlock relay from firing when the lock signal is sent or the lock relay from firing when the unlock signal is sent. Without the diodes, neither the service body nor the vehicle locks will work. To access the circuits, the passenger kick panel/sill cover must be removed and the carpet rolled towards the center of the vehicle. The wires come from under the front seat into a trough. They exit the trough at the forward end near the kick panel. This is where the wires should be accessed (see photo's on following page) The wires to be spliced are violet with a light green tracer and light green with a dark green tracer. Please note that there are a number of wires in this bundle with similar wire colors. Test these circuits with a circuit tester or volt meter prior to making the splice. Both circuits will pulse high when the appropriate lock or unlock button is pressed. Construct the circuit as shown in the attached schematic. The 1N5359 diodes should be located inside the cab, covered with heat shrink in an area that would protect them from moisture and abuse. The most convenient location seems to be behind the kick panel. Likewise, the relays should be mounted inside the cab, in an area that will protect from moisture and abuse. The most likely location is somewhere behind the dash. Wire size should be sized according to the fuse used upstream and the fuse sized based on the added door lock loads. We recommend using relays with suppression on the coils to prevent damaging voltage spikes. The relay contact and fuse ratings should be sized to handle the total current demand of all of the lock motors in the service body.

Upfitter added door lock motors on vehicles without a VSIM - schematic

Upfitter added door lock motors without VSIM controlled lock/unlock relays

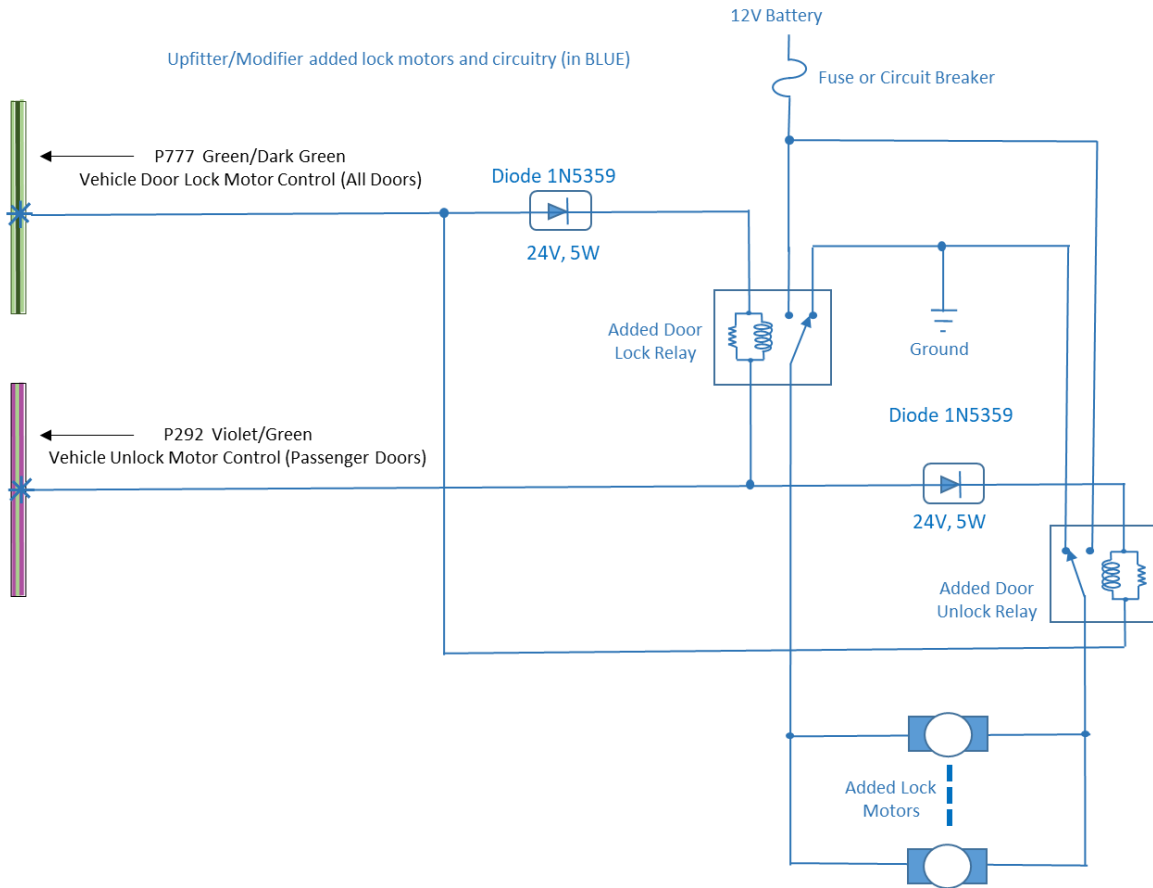

Where to access the door lock/unlock circuits on left side of vehicle

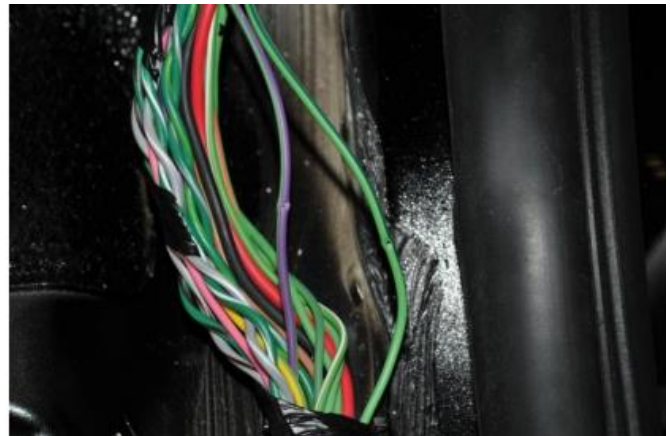

Ram Heavy Duty & Cab Chassis Remote Door Lock Control 2019+