CHASSIS CAB FRAME ALTERATION RECOMMENDATIONS

The recommendations below are suggestions for the frame alteration best practices to accommodate specialty upfit components. But the persons modifying the frame must assume complete responsibility for assembly, performance, reliability and compliance to all applicable FMVSS standards.

NOTE: 5500 120 CA models used for Roll Back Carrier applications require specific frame reinforcements. These reinforcements are shown at the end of this document and are included in the carrier package. (Sales Code : AH1)

For Dump Body Installation Requirements see instructions in the **DESIGN RECOMMENDATIONS/CAUTIONARY NOTES** Section.

Holes

Holes are not to be drilled in the top or bottom flanges of the frame rails. Holes to mount equipment should always be in the vertical web of the rail. Preferably, in existing holes if possible. If new holes are required, they should meet the following guidelines:

1. Hole diameter should not exceed 20mm (0.75 in.)
2. The edge of the hole should be no less than 40mm (1.60 in.) from the top or bottom of the frame.
3. The minimum distance edge to edge between any two holes should be no less than twice the diameter of the larger hole.
4. All holes should be drilled in the frame using appropriate drilling practice and safety precautions.
5. Be especially careful if holes must be drilled near the fuel tank. Pay particular attention to the routing of brake lines, fuel lines, or wiring on the inside of the rail when drilling holes on the outside of the rail.
6. For Maximum Durability, it is recommended that the two holes in the web of the rail where the taillights are attached have two bolts installed per side.

Welding

1. Avoid welding near the fuel tank, fuel lines, brake lines or other components that may be damaged.
2. Components near the welding area which could be damaged by excessive heat must be removed or adequately shielded.
3. Disconnect the battery(ies), negative terminal posts.
4. Precautionary measures should be used to prevent electrical system component or wiring damage.
5. The frame e-coating must be removed from the weld and surrounding area.
6. Use proper welding techniques to avoid stress risers that may adversely affect frame performance.

After welding:

1. Carefully inspect electrical components and wiring for shorts or other damage.
Apply protective coating to the areas where the coating was removed.

Ram Chassis Cab Frame Alteration Instructions

Rivet Replacement

If the original rivets require replacement, bolts of the same size or larger that fit in the existing holes are acceptable. The nuts and bolts should include flanged heads. Hardened washers are acceptable in placed of flanged heads. The fasteners should be at least grade 8 or grade 10.9 metric. The joint and fasteners should be covered with corrosion protection after tightening the fasteners.

Frame Length Alterations

If shortening the frame at the rear overhang (4500/5500 Chassis Cab Frame)

- 1. Drill out the rivets that attach the rear-most Fuel Tank Crossmember to the Frame Rear Rails. Fig 1.**
- 2. Cut off the Frame Rails at the location shown in Fig 2. The preferred method to cut the Frame Rail is with a Saw or a Cut-off Wheel.**
- 3. Remove the (6) bolts/nuts from the Rear Spring Rear Hanger (RSRH) Bracket Fig 3.**
- 4. Relocate the Fuel Tank Crossmember in close proximity of the (RSRH) Bracket holes. Using the holes in the RSRH Bracket as a template, drill same size dia. holes (13.0mm) in the web & the lower flange of the Fuel Tank Crossmember. Aligned with the upper flange hole in the Fuel Tank Crossmember, drill a new hole in the upper flange of the Frame Rear Rail and enlarge the Fuel Tank Crossmember hole to (13.0mm) dia. Total of (4) holes required per side. Fig 4.**
- 5. Use grade 8 (grade 10.9 metric) M12 bolts/nuts/ flat washers to attach the Fuel Tank Crossmember to the Frame Rear Rails. Total of (4) each required per side. Fig 5.**
- 6. If the cut-off dimension is shorter than the dimension shown in Fig 2, than use the Fuel Tank Crossmember as a template to drill additional holes (13.0mm dia.) in the Frame Rear Rails, and enlarge the holes in the Fuel Tank Crossmember Fig 6. Use grade 8 (grade 10.9 metric) M12 bolts/nuts/ flat washers to attach the Fuel Tank Crossmember to the Frame Rear Rails. Total of (4) each required per side. Fig 4A.**
- 7. Areas of the frame that have now become exposed metal should be coated with a corrosion protection coating.**

Fig. 1

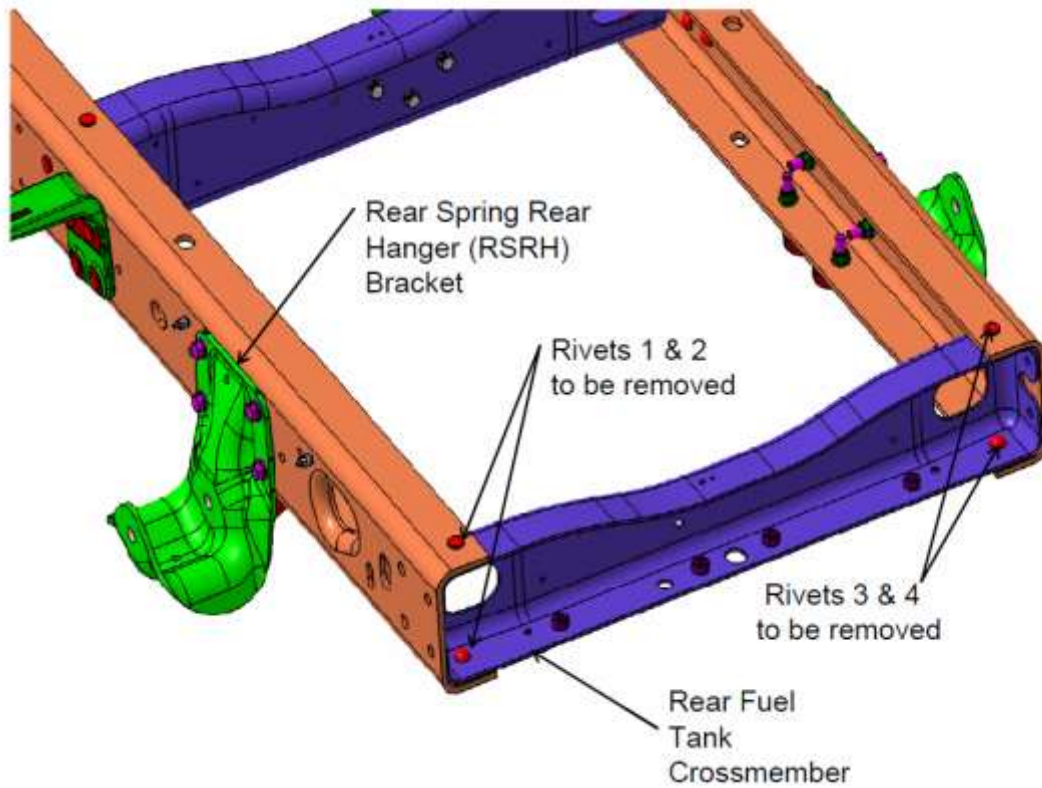

Ram Chassis Cab Frame Alteration Instructions

Rear Spring Rear Hanger
(RSRH) Bracket

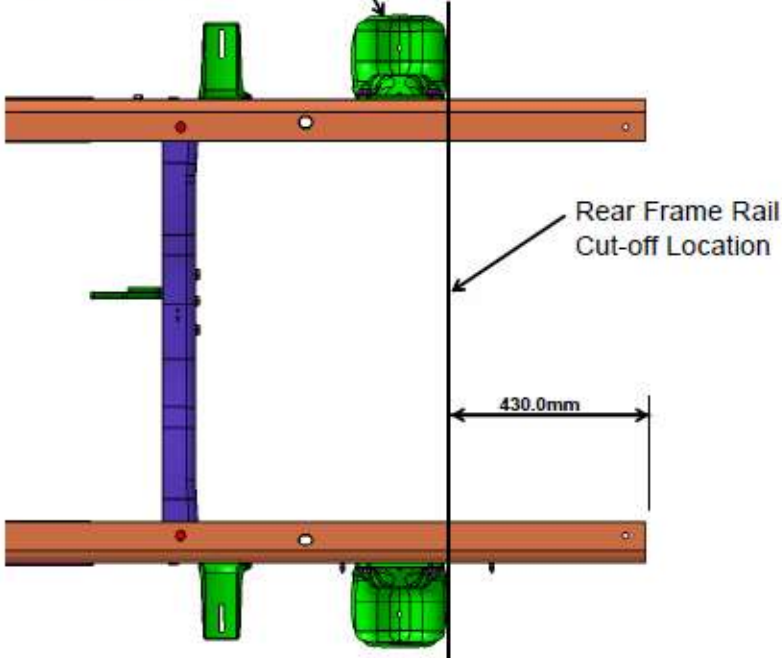
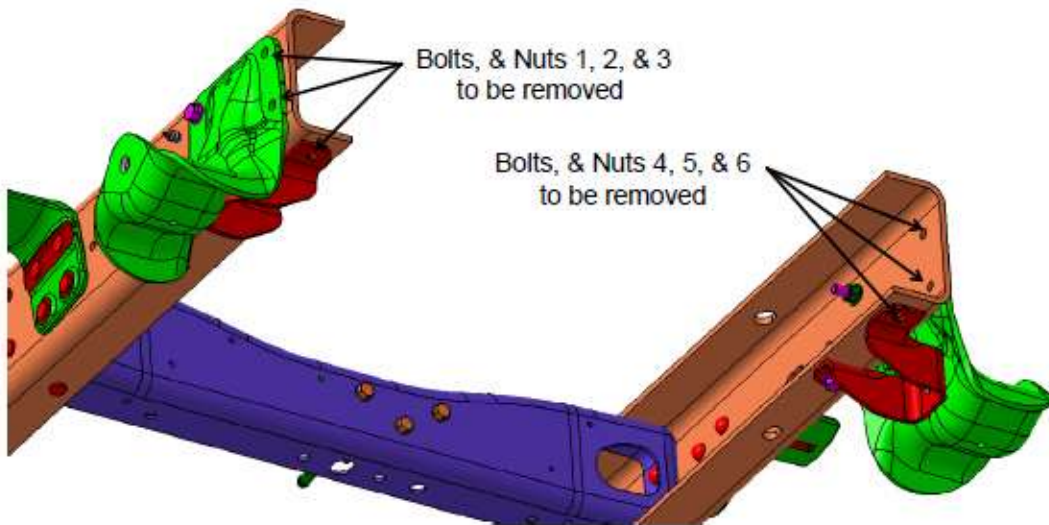
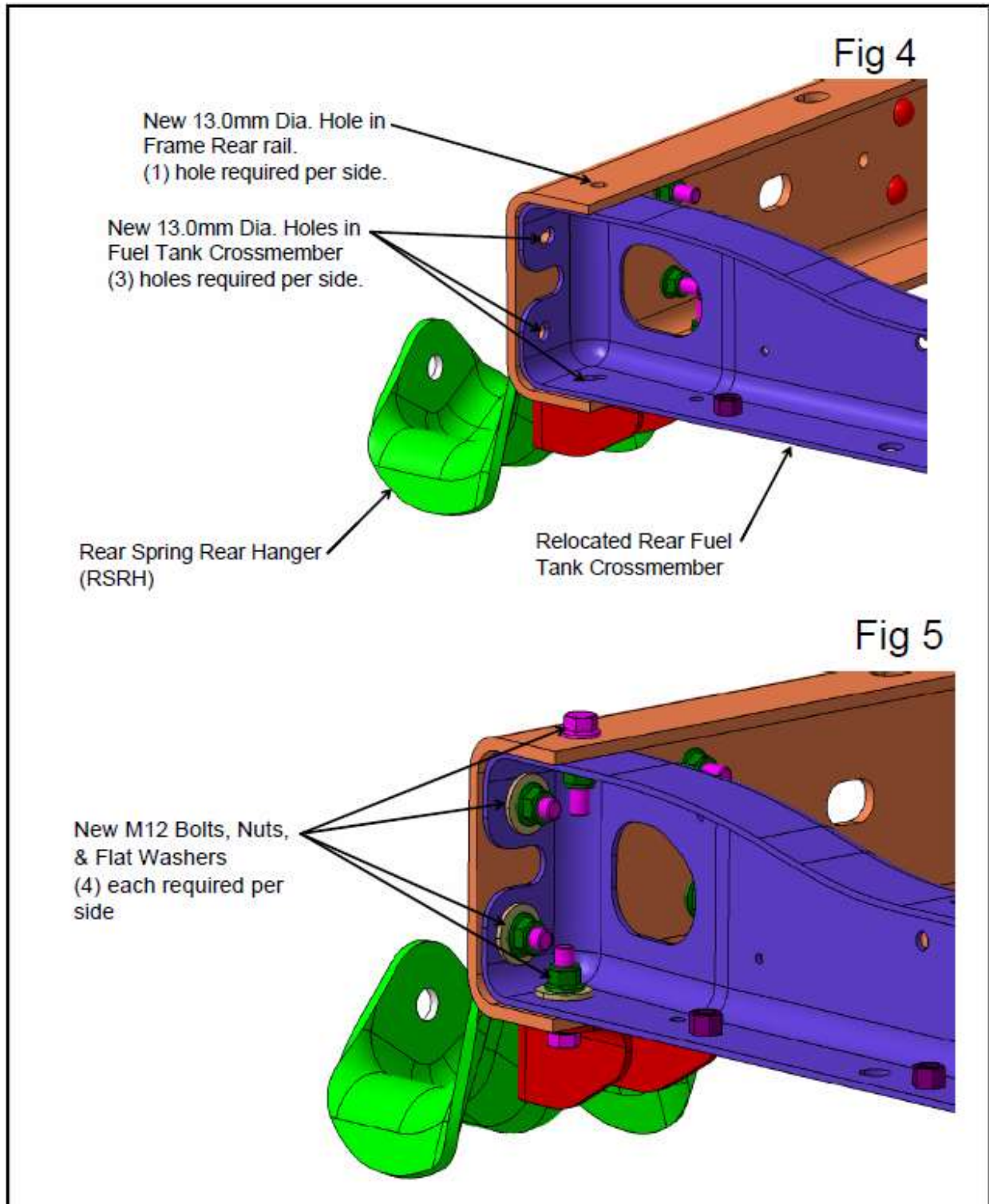

Fig 2

Fig 3



Ram Chassis Cab Frame Alteration Instructions



Ram Chassis Cab Frame Alteration Instructions

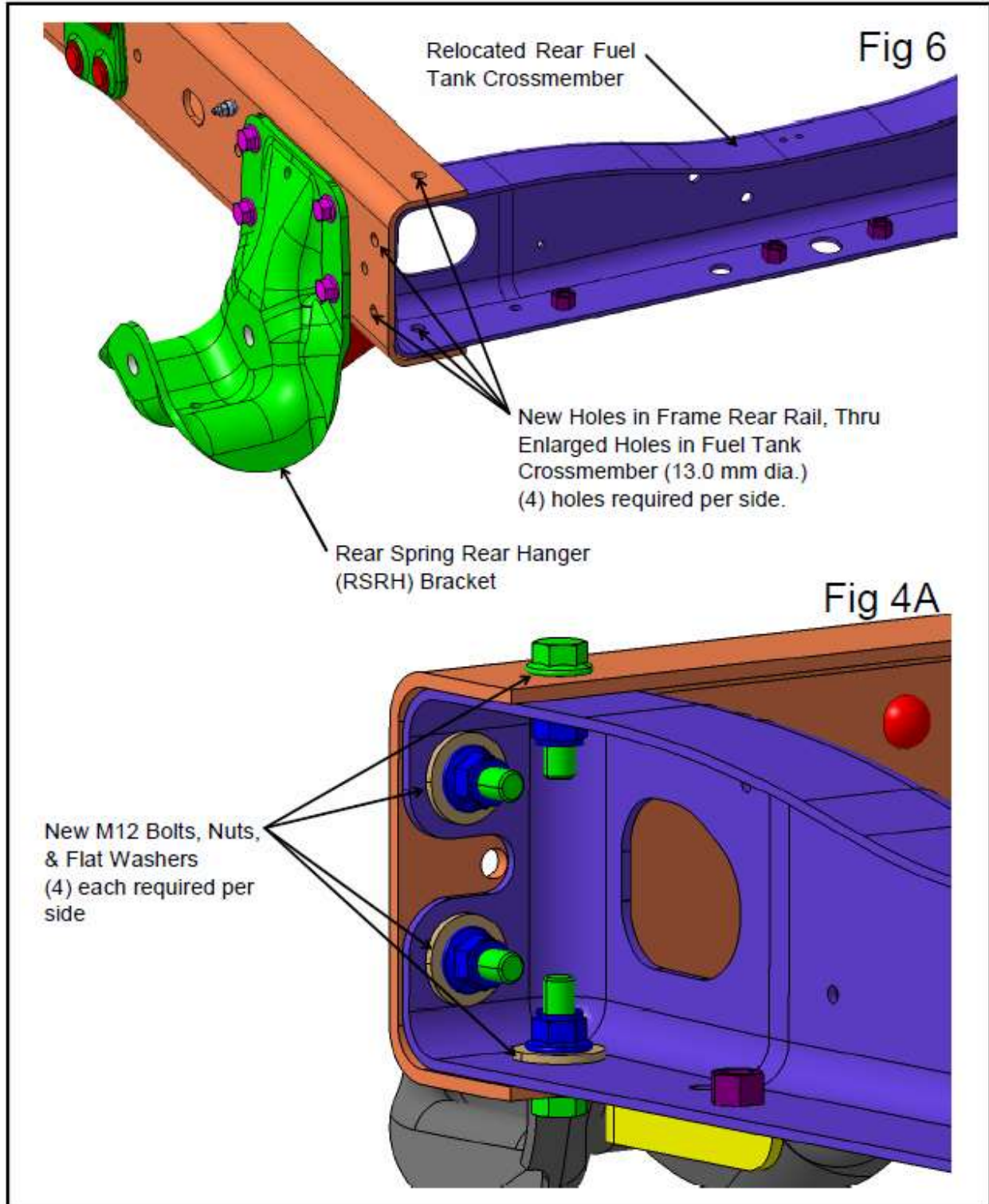

Ram Chassis Cab Frame Alteration Instructions

Frame Length Alterations

If shortening the frame at the rear overhang (3500 Chassis Cab Frame)

1. Drill out the rivets that attach the rear-most Fuel Tank Crossmember to the Frame Rear Rails. Fig 1A
2. Cut off the Frame Rear Rails short of the RSRH Bracket attachment as shown in Fig 2A. The preferred method to cut the Frame is with a Saw or a Cut-off Wheel.
3. Use the relocated Fuel Tank Crossmember as a template to drill additional holes in the Frame Rear Rails, and enlarge the holes in the Fuel Tank Crossmember to 13.0mm dia. for bolt attachment. Fig 3A.
4. Use grade 8 (grade 10.9 metric) M12 bolts/nuts/ flat washers to attach the Fuel Tank Crossmember to the Frame Rear Rails, Fig 4A.
5. Areas of the Frame that have now become exposed metal should be coated with a corrosion protection coating.

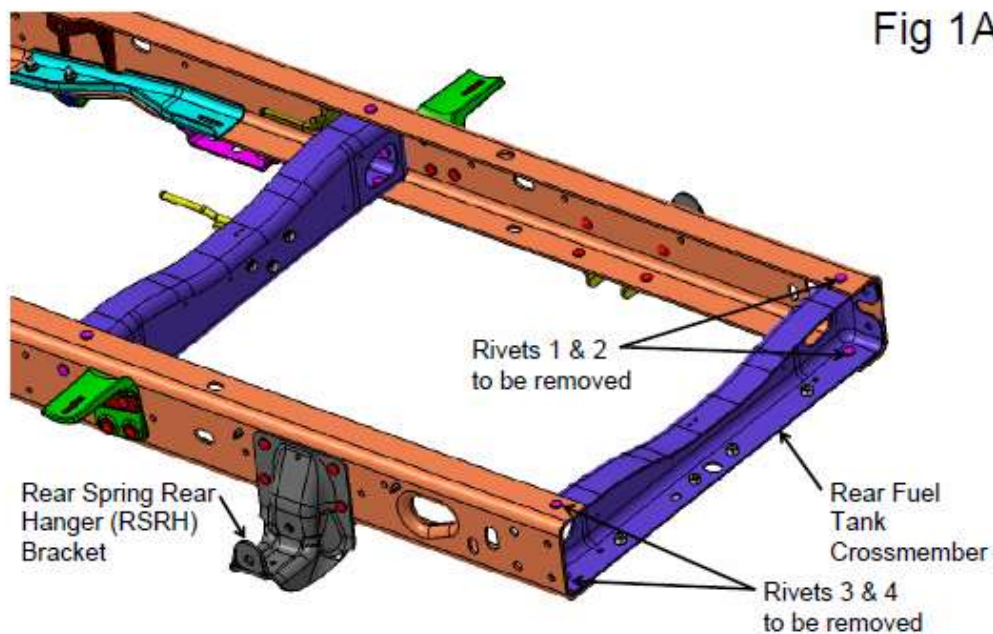

Ram Chassis Cab Frame Alteration Instructions

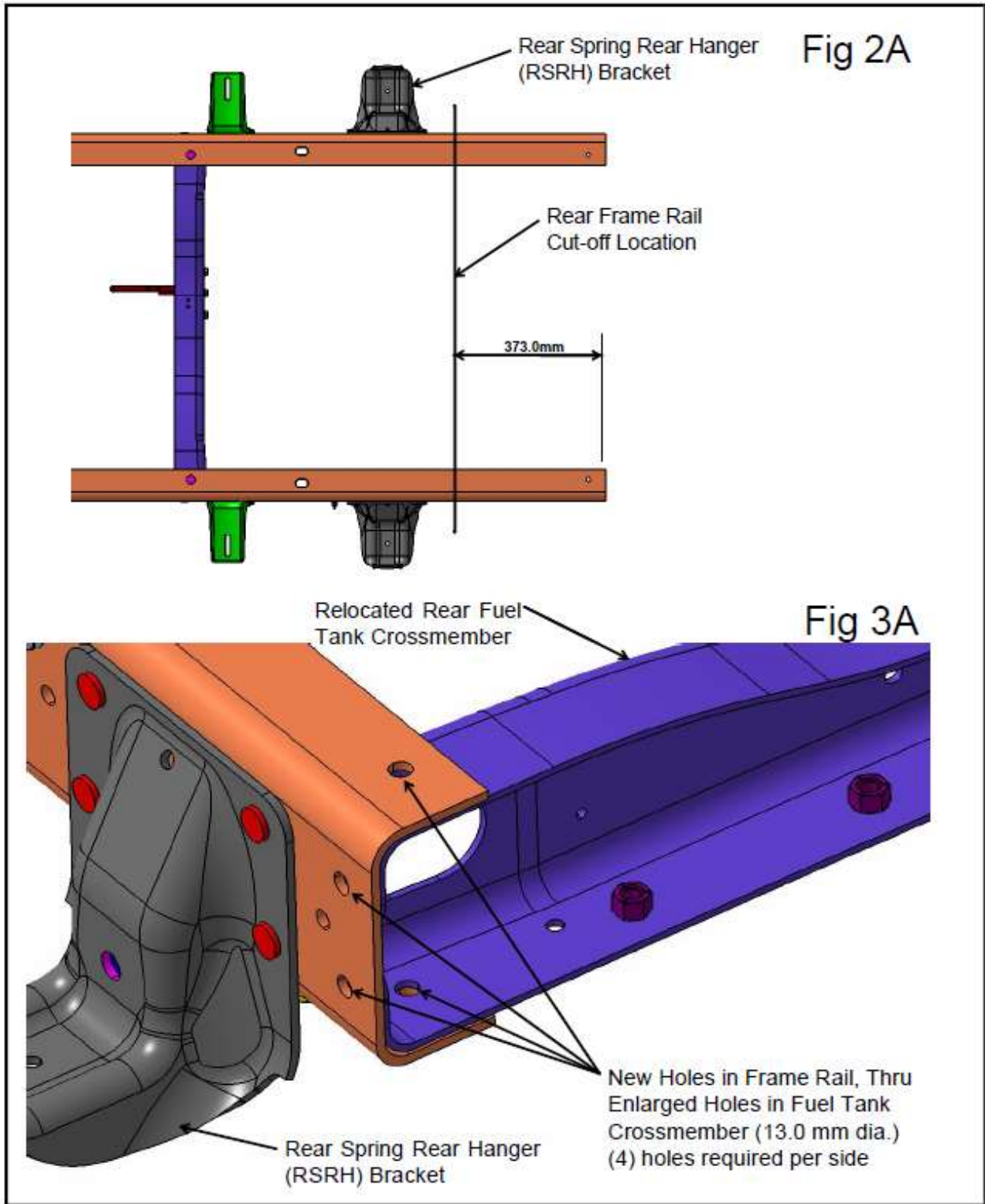

Ram Chassis Cab Frame Alteration Instructions

Fig 4A

New M12 Bolts, Nuts,
& Flat Washers
(4) each required per
side

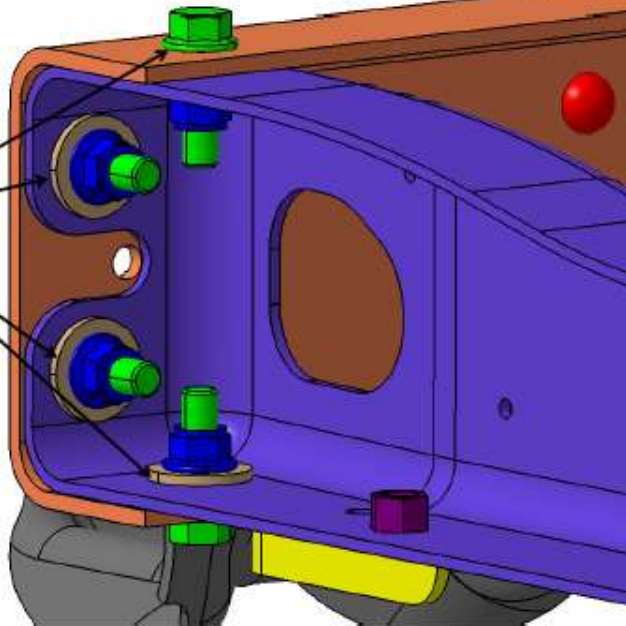

Frame Length Alterations

If lengthening the frame:

1. In preparation for extending the Frame Rear Rails, remove the e-coat from the Frame Rear Rails surfaces with a Wire Wheel or equivalent.
2. For a Frame Extension Channel, use a section of comparable shape & thickness to the Frame Rear Rails of mild (low carbon) steel (2) required.
3. Chamfer the mating areas of the Frame Rear Rails and the new Frame Extension Channels, Fig 7
4. Drill out only the lower flange Fuel Tank Crossmember Rivet both sides, Fig 8
5. Disconnect the battery(ies) negative terminal posts, and the main ground to the TIPM/Battery.
6. Weld a Lower Reinforcing Plate to the lower flange of the Frame Extension Channel, and extend the Lower Reinforcing Plate far enough to allow bolting through the Fuel Tank Crossmember, Fig 9.
7. Butt weld both sides of the Frame Rear Rail and the Frame Extension Channel together at the top flange and vertical web of the Frame Rear Rail, omitting any welding on the lower flange. Grind smooth the outer surface of the Frame Rear Rail vertical web. Fig 10.
8. Using the hole in the Rear Fuel Tank Crossmember lower flange drill through a (13.0mm dia.) hole enlarging both the Fuel Tank Crossmember, and Frame Rear Rail both sides, Fig 11
8. Clamp a Side Reinforcement Plate (1/4" x 4.0" x 12.0" mild steel) to the Frame Rear Rail vertical web. Drill (2) (13.0mm dia.) holes in the Side Reinforcement Plate, (1) through the Frame Rear Rail upper Shear Plate hole, and (1) through the enlarged Fuel Tank Crossmember lower web hole. Duplicate (2) more (13.0mm dia.) holes in the Side Reinforcement Plate through the Frame Extension Channel. Stitch weld the Side Reinforcement Plate onto the Frame Rear Rail and the Frame Extension Channel avoiding the corners, Fig 12.
9. Use grade 8 (grade 10.9 metric) M12 bolts/nuts/ flat washers to attach both the Lower and the Side Reinforcing Plates to the Frame Rear Rails and the Frame Extension Channel. Total (5) bolts/nuts/flat washers required per side, Fig 13.
10. Coat the Frame Rear Rail, Frame Extension, and both Lower and Side Reinforcing Plates on both sides with a corrosion protective coating. Reconnect the electrical components.

Ram Chassis Cab Frame Alteration Instructions

Fig 7

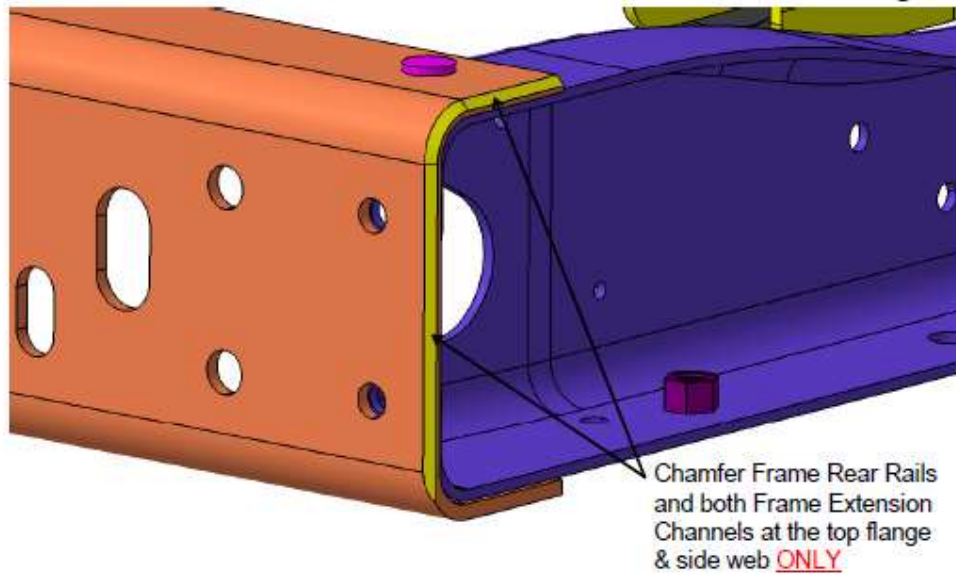
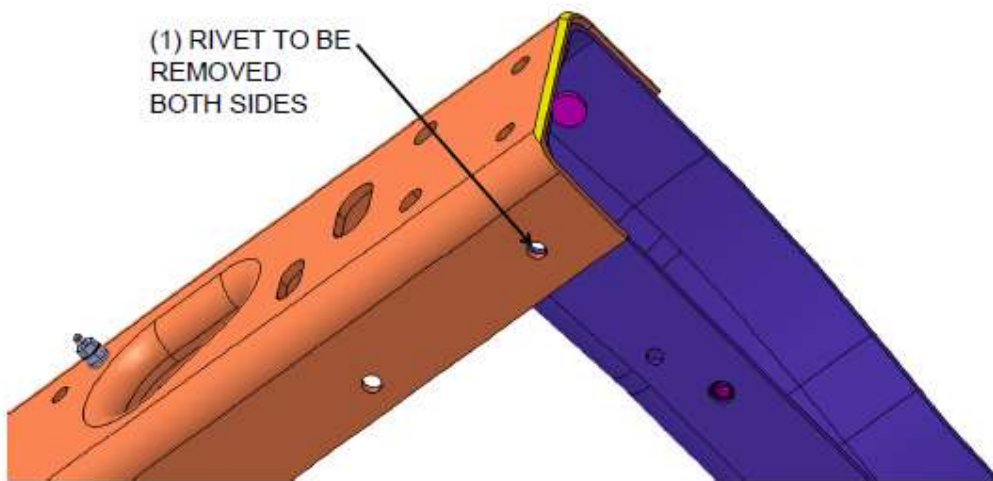
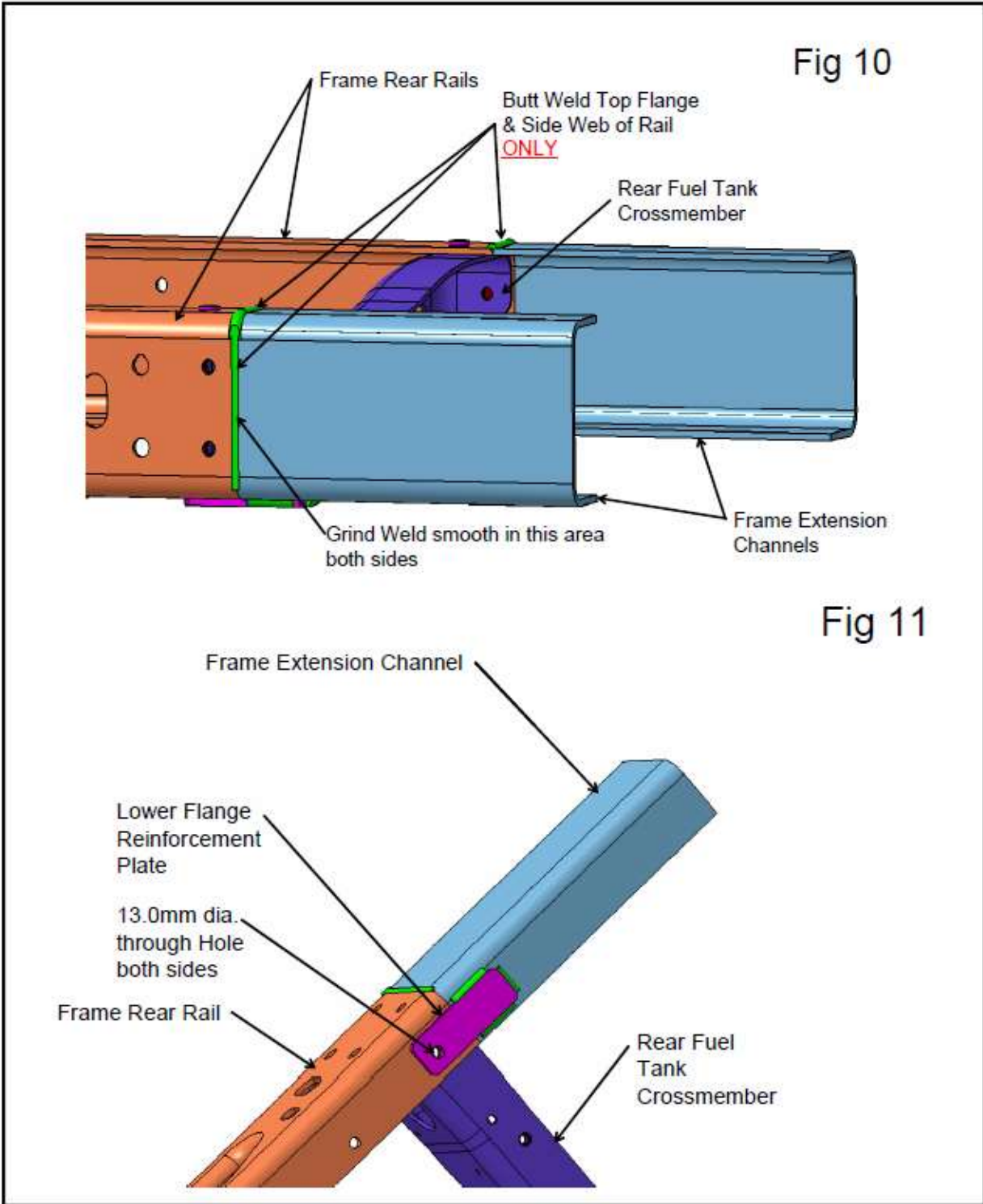

Fig 8



Ram Chassis Cab Frame Alteration Instructions



Ram Chassis Cab Frame Alteration Instructions

Fig 12

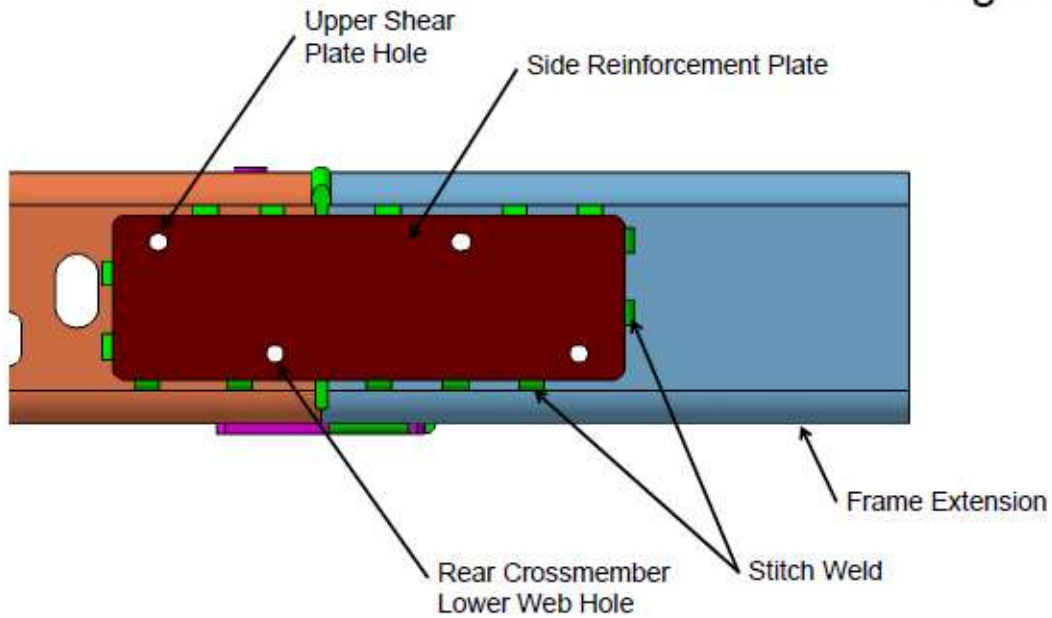
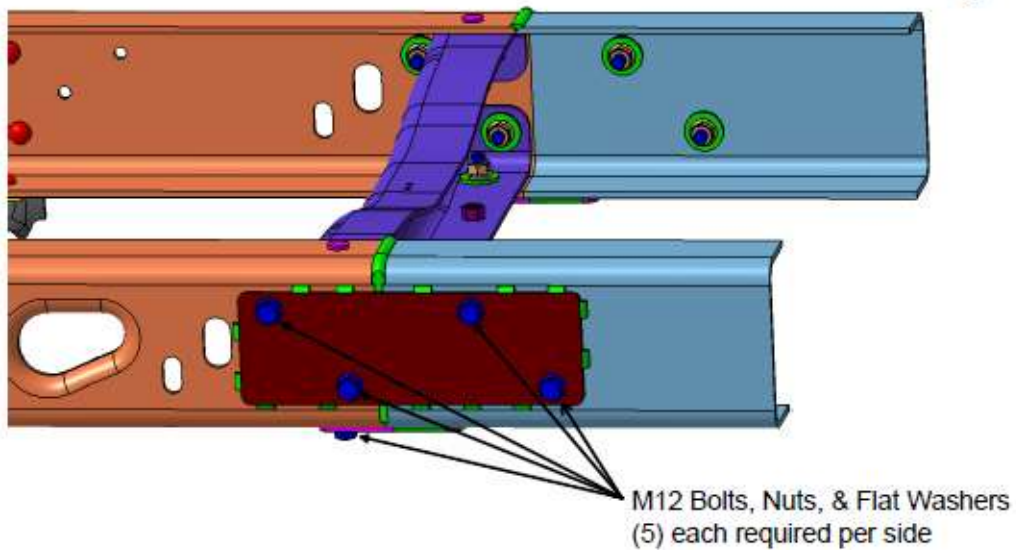

Fig 13



Ram Chassis Cab Frame Alteration Instructions