

2021 UPFITTER SCHEMATIC

3500/4500/5500 CHASSIS CABS

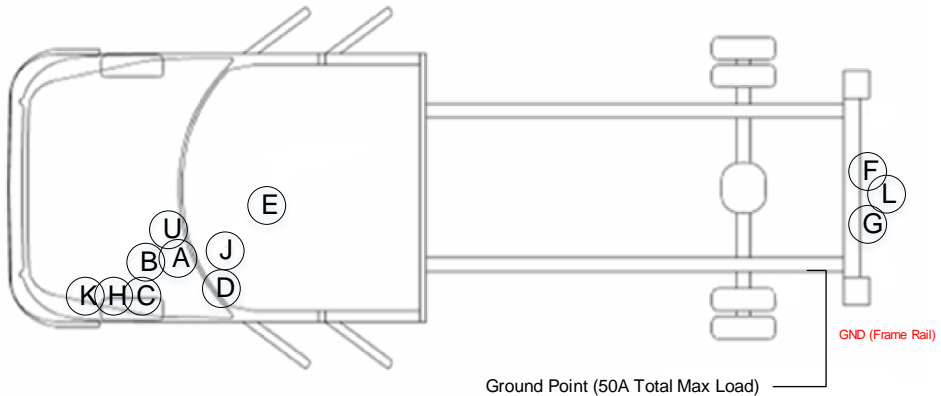

UPFITTER PASS THROUGH	WIRES	MAX ALLOWABLE CONTINUOUS AMPERAGE
Trailer Tow Lighting	W751,W752,W753, W756	14A
Trailer Tow Battery, Brake Ground	W750, W754,W755	21A
Pass- through Circuits	W547,W548, W549, W550	28A

- (A) Aux PDC (auxiliary Power Distribution Center-relay/fuse box) Underhood
- (B) 2 Upfitter Connectors (Light and Dark Gray)
- (C) PDC (main Power Distribution Center-relay/fuse box) underhood
- (D) Port Upfitters Connectors, Under Dash Board near park brake bracket / Steering Column
- (E) PTO Connector Wires located underneath vehicle at Transmission Bell Housing, Left (Driver) Side
- (F) Park sense connector
- (G) Vehicle Wiring, Blunt Cut (with Heat Shrink) Rear of Frame
- (H) Blunt Cut (with Heat Shrink) wires underneath the PDC
- (J) VSIM Module located interior of vehicle under dash
- (K) Aux 6/PTO jumper connector, alongside left (Drivers Side) fender inner
- (L) Rear Camera Connector
- (U) Dash Pass Thru

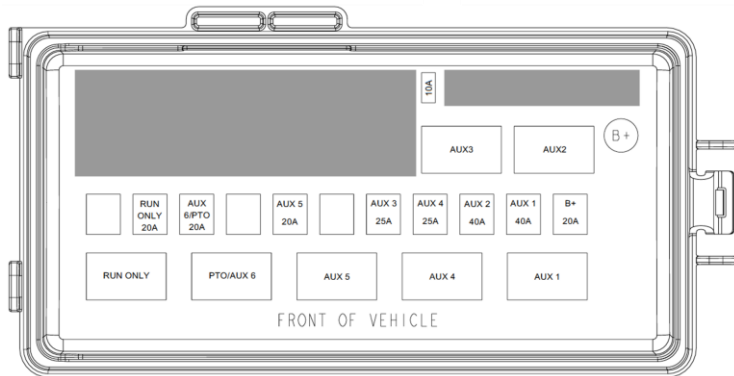

The auxiliary switch function logic (BATTERY or IGNITION FED, MOMENTARY or LATCHING, LAST STATE) is programmed using the EVIC display in the instrument cluster.

Max Combined Fuse "rating" allowed for Aux SW 1, 2, 3, 4, 5, 6/PTO, Run Only & Battery is 210A. Fuses can be relocated in box as necessary.

Max allowable combined total continuous amperage draw is 135A. Max fuse "rating" in any one location is 40A, except the Run Only fuse allowed only to 20A.

***The upfitter/customer is responsible for placing the correct fuse in the correct location depending on the actual load.**

***Amperages shown in schematics are for fuses/circuits as installed for the vehicle as sold and will change as fuses are reconfigured.**

MAX ALLOWABLE CONTINUOUS AMPERAGE DRAW PER FUSE RATING

FUSE RATING	MAX ALLOWABLE CONTINUOUS AMPERAGE
20A	14A
25A	17.5A
40A	28A

2021 UPFITTER SCHEMATIC

2500/3500 PICKUP BOX DELETE (XBC) With AUX switches (LHL)

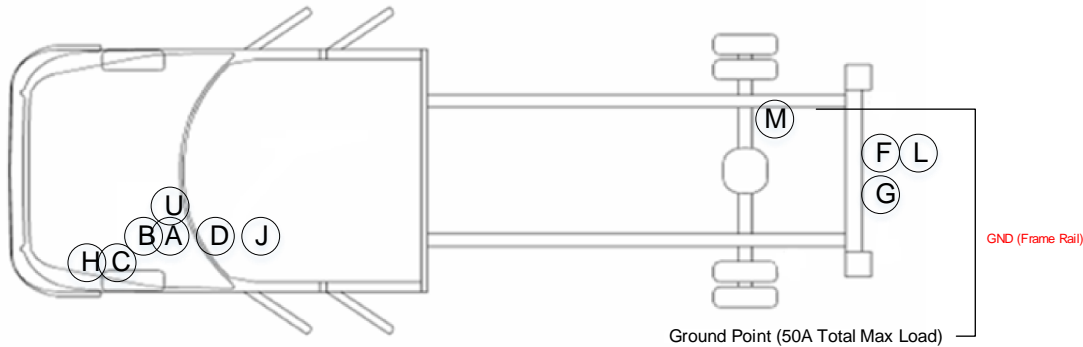

- (A) Aux PDC (auxiliary Power Distribution Center-relay/fuse box) Underhood
- (B) 2 Upfitter Connectors (Light and Dark Gray)
- (C) PDC (main Power Distribution Center-relay/fuse box) underhood
- (D) Port Upfitters Connectors, Under Dash Board near park brake bracket / Steering Column
- (F)(G) Vehicle Wiring, Blunt Cut (with Heat Shrink) Rear of Frame
- (H) Blunt Cut (with Heat Shrink) wires underneath the PDC
- (J) VSIM Module located interior of vehicle under dash if equipped (sales code XXS)
- (M) Blunt Cut (with Heat Shrink) Stop Lamp Signal – CHMSL Feed
- (L) Rear Camera Connector
- (U) Dash Pass Thru

UPFITTER PASS THROUGH	WIRES	MAX ALLOWABLE CONTINUOUS AMPERAGE
Trailer Tow Lighting	W751, W752, W753, W756	14A
Trailer Tow Battery, Brake Ground	W750, W754, W755	21A
Pass- through Circuits	W547, W548, W549, W550	28A

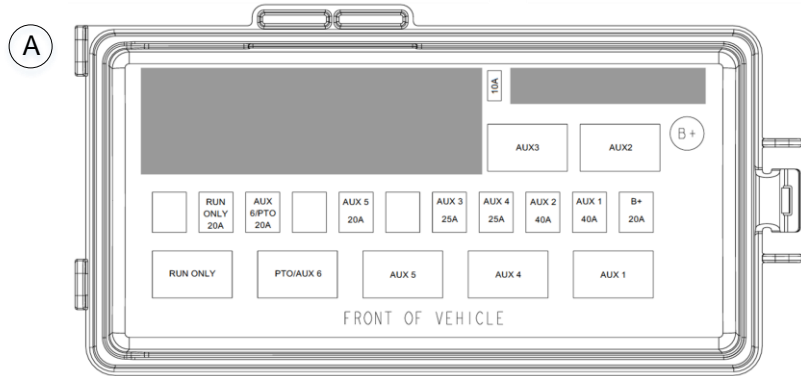

The auxiliary switch function logic (BATTERY or IGNITION FED, MOMENTARY or LATCHING, LAST STATE) is programmed using the EVIC display in the instrument cluster.

Max Combined Fuse "rating" allowed for Aux SW 1, 2, 3, 4, 5, 6, Run Only & Battery is 210A. Fuses can be relocated in box as necessary. Max allowable combined total continuous amperage draw is 135A. Max fuse "rating" in any one location is 40A, except the Run only feed fuse allowed only to 20A.

***The upfitter/customer is responsible for placing the correct fuse in the correct location depending on the actual load.**

***Amperages shown in schematics are for fuses/circuits as installed for the vehicle as sold and will change as fuses are reconfigured.**

MAX ALLOWABLE CONTINUOUS AMPERAGE DRAW PER FUSE RATING

FUSE RATING	MAX ALLOWABLE CONTINUOUS AMPERAGE
20A	14A
25A	17.5A
40A	28A

2021 UPFITTER SCHEMATIC

2500/3500 PICKUP BOX ON With AUX switches (LHL)

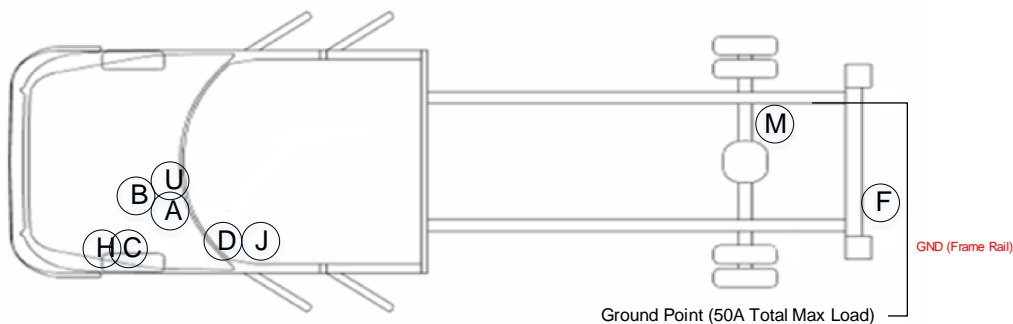

- (A) Aux PDC (auxiliary Power Distribution Center-relay/fuse box) Underhood
- (B) 2 Upfitter Connectors (Light and Dark Gray)
- (C) PDC (main Power Distribution Center-relay/fuse box) underhood
- (D) Port Upfitters Connectors, Under Dash Board near park brake bracket / Steering Column
- (F) Vehicle Wiring, Blunt Cut (with Heat Shrink) Rear of Frame
- (H) Blunt Cut (with Heat Shrink) wires underneath the PDC
- (J) VSIM Module located interior of vehicle under dash if equipped (sales code XXS)
- (M) Blunt Cut (with Heat Shrink) Stop Lamp Signal – CHMSL Feed
- (U) Dash Pass Thru

UPFITTER PASS THROUGH	WIRES	MAX ALLOWABLE CONTINUOUS AMPERAGE
Trailer Tow Lighting	W751,W752,W753, W756	14A
Trailer Tow Battery, Brake Ground	W750, W754,W755	21A
Pass- through Circuits	W547,W548, W549, W550	28A

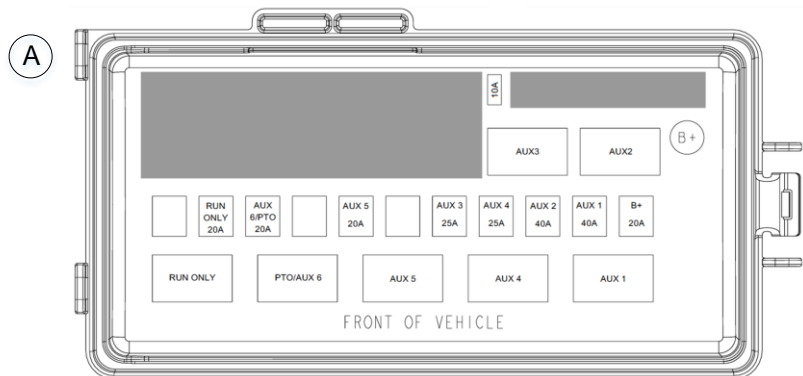

The auxiliary switch function logic (BATTERY or IGNITION FED, MOMENTARY or LATCHING, LAST STATE) is programmed using the EVIC display in the instrument cluster.

Max Combined Fuse "rating" allowed for Aux SW 1, 2, 3, 4, 5, 6, Run Only & Battery is 210A. Fuses can be relocated in box as necessary.
Max allowable combined total continuous amperage draw is 135A.
Max fuse "rating" in any one location is 40A, except the battery feed fuse allowed only to 20A.

***The upfitter/customer is responsible for placing the correct fuse in the correct location depending on the actual load.**

***Amperages shown in schematics are for fuses/circuits as installed for the vehicle as sold and will change as fuses are reconfigured.**

MAX ALLOWABLE
CONTINUOUS AMPERAGE
DRAW PER FUSE RATING

FUSE RATING	MAX ALLOWABLE CONTINUOUS AMPERAGE
20A	14A
25A	17.5A
40A	28A

2021 UPFITTER SCHEMATIC

2500/3500 PICKUP Without AUX switches (LHL)

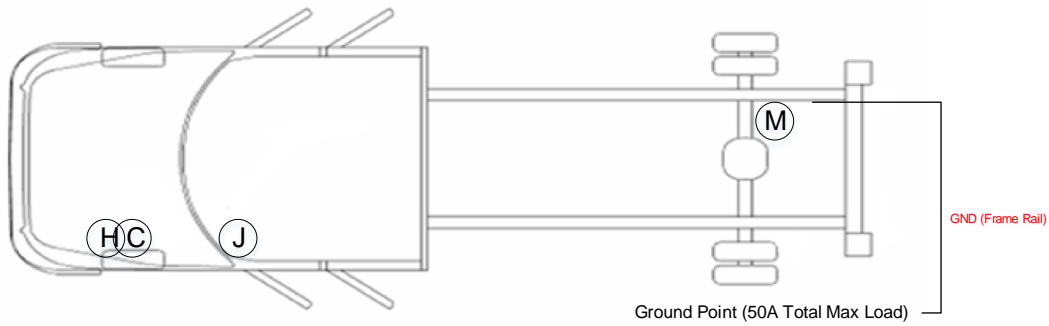

- Ⓒ PDC (main Power Distribution Center-relay/fuse box) underhood
- Ⓗ Blunt Cut (with Heat Shrink) wires underneath the PDC
- Ⓙ VSIM Module located interior of vehicle under dash if equipped(sales code XXS)
- Ⓜ Blunt Cut (with Heat Shrink) Stop Lamp Signal – CHMSL Feed

2021 UPFITTER SCHEMATIC

3500/4500/5500 CHASSIS CAB
6.7 Diesel AISIN Trans w/PTO
(Sales codes LBN/LBV)

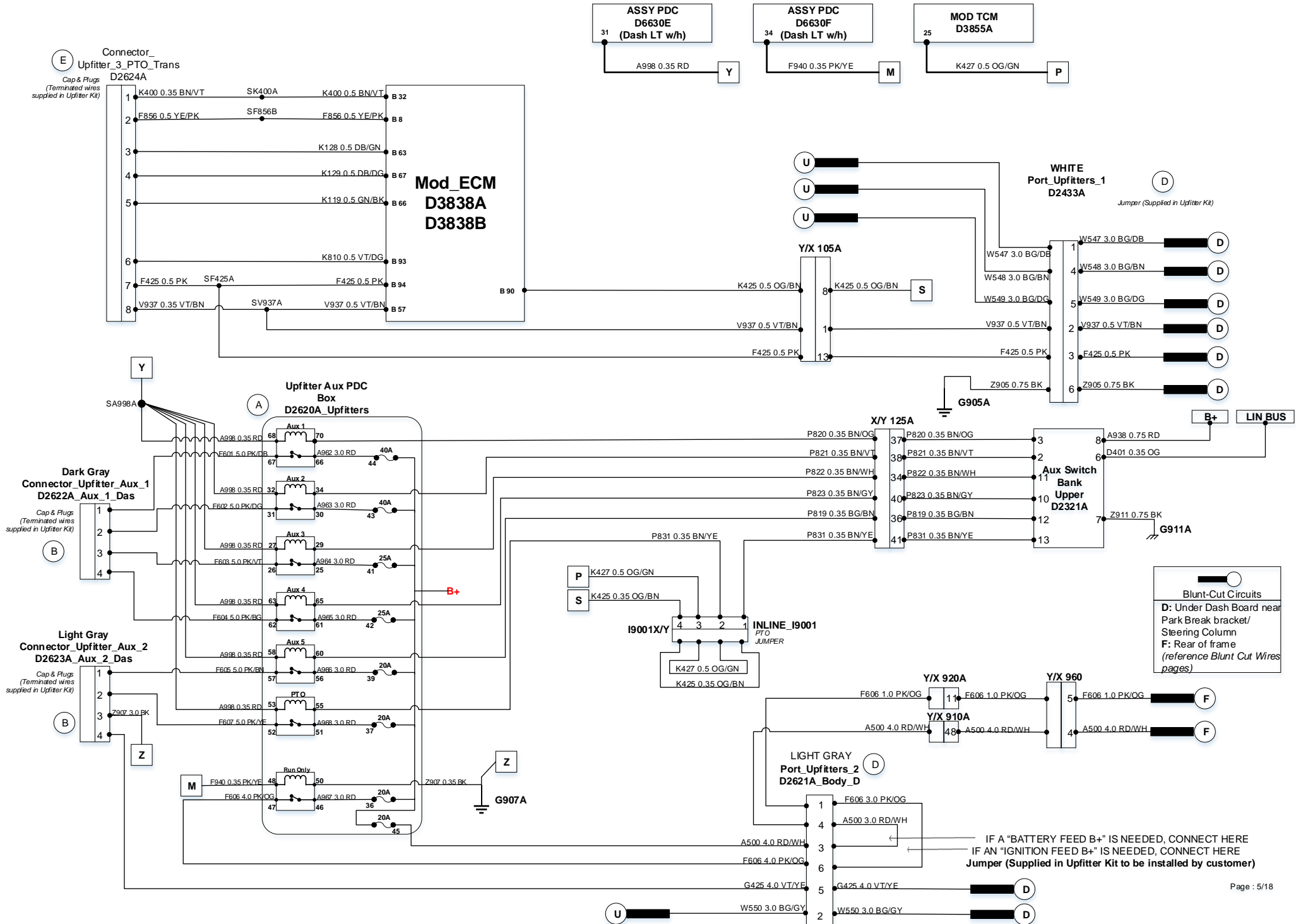

2021 UPFITTER SCHEMATIC

3500/4500/5500 CHASSIS CAB
6.4 Gas Asin Trans
w/PTO (Sales codes LBN/LBV)

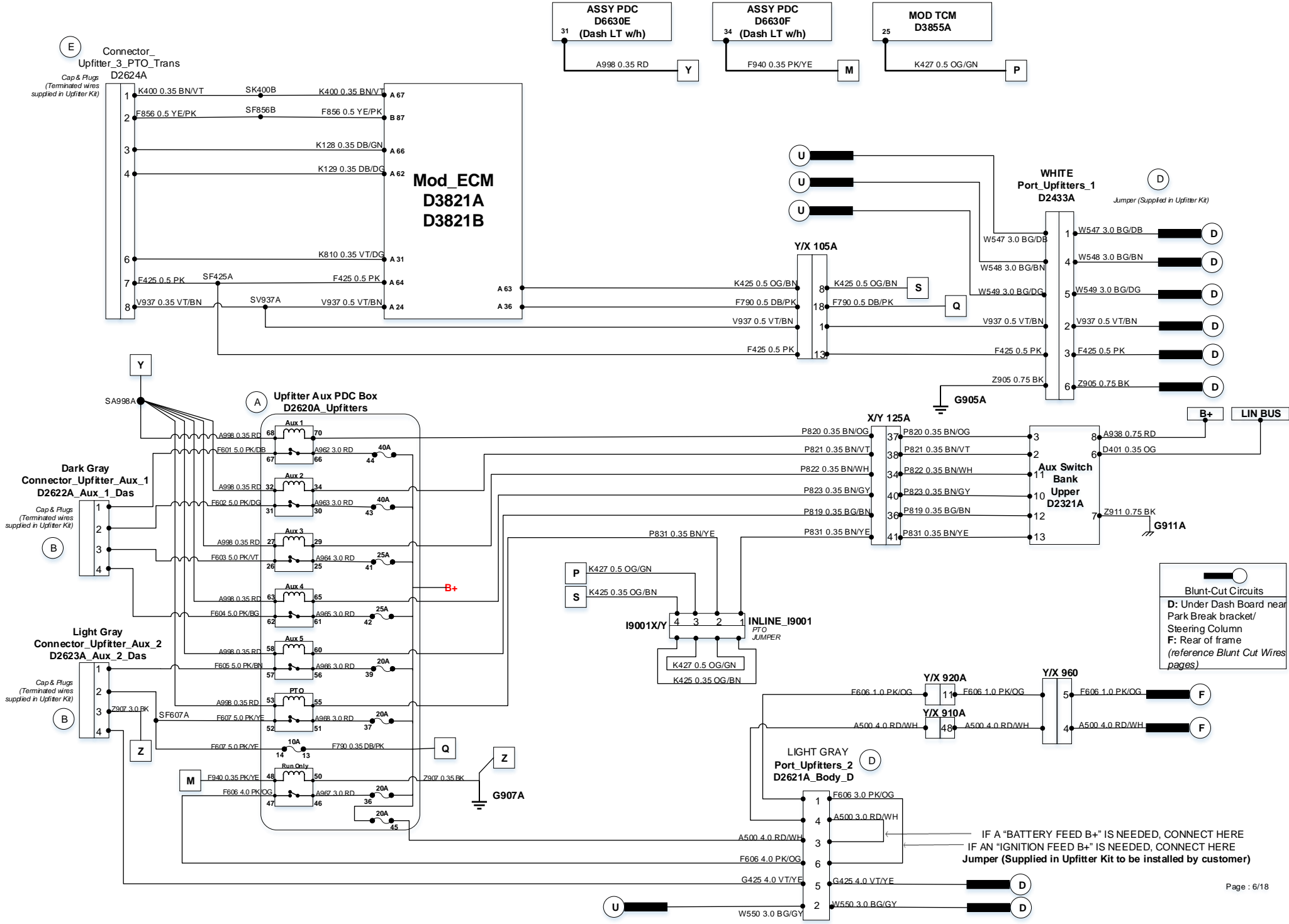

2021 UPFITTER SCHEMATIC

3500/4500/5500 CHASSIS CAB
6.7 Diesel w/o PTO

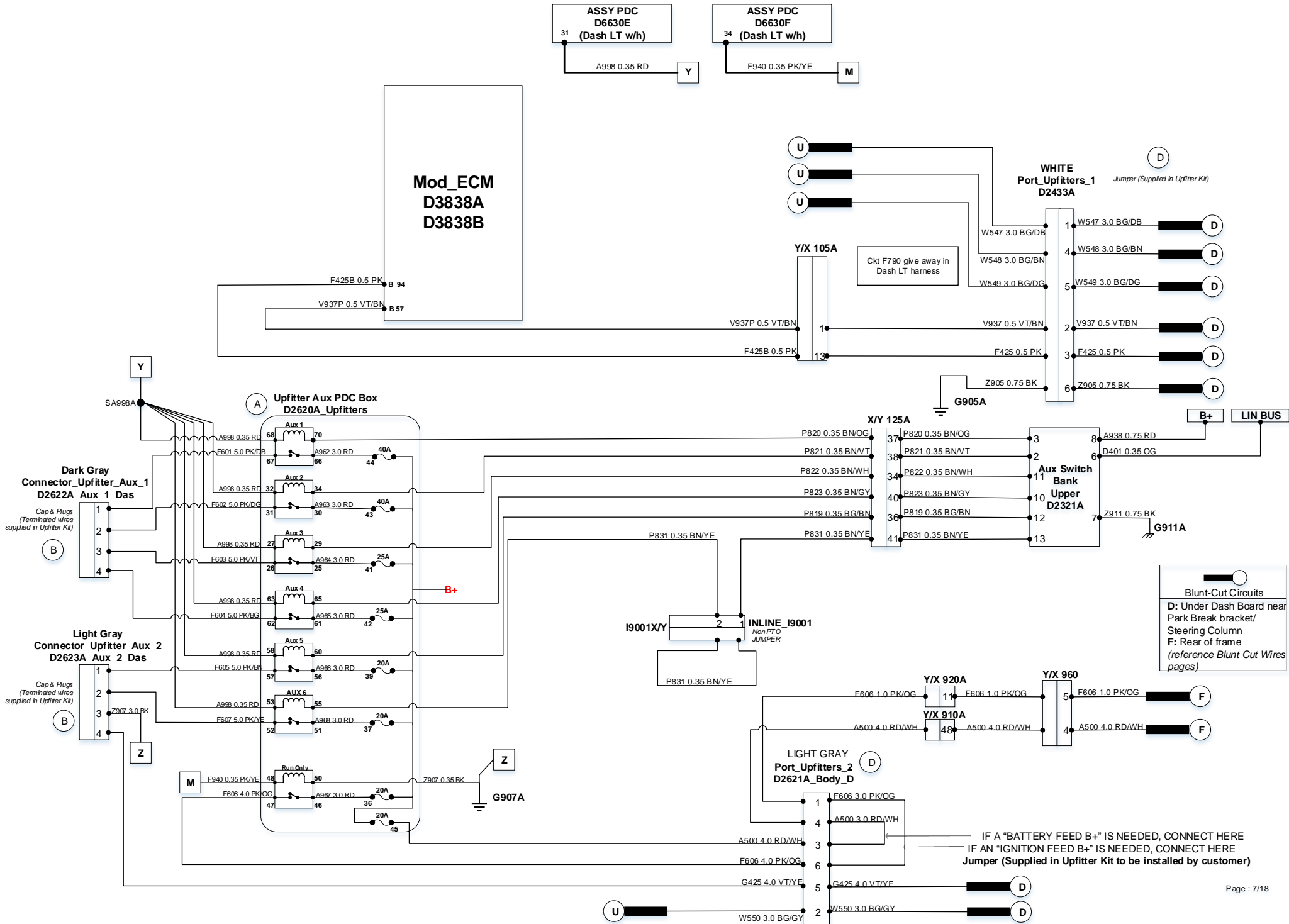

2021 UPFITTER SCHEMATIC

3500/4500/5500 CHASSIS CAB
6.4L Gas – w/o PTO

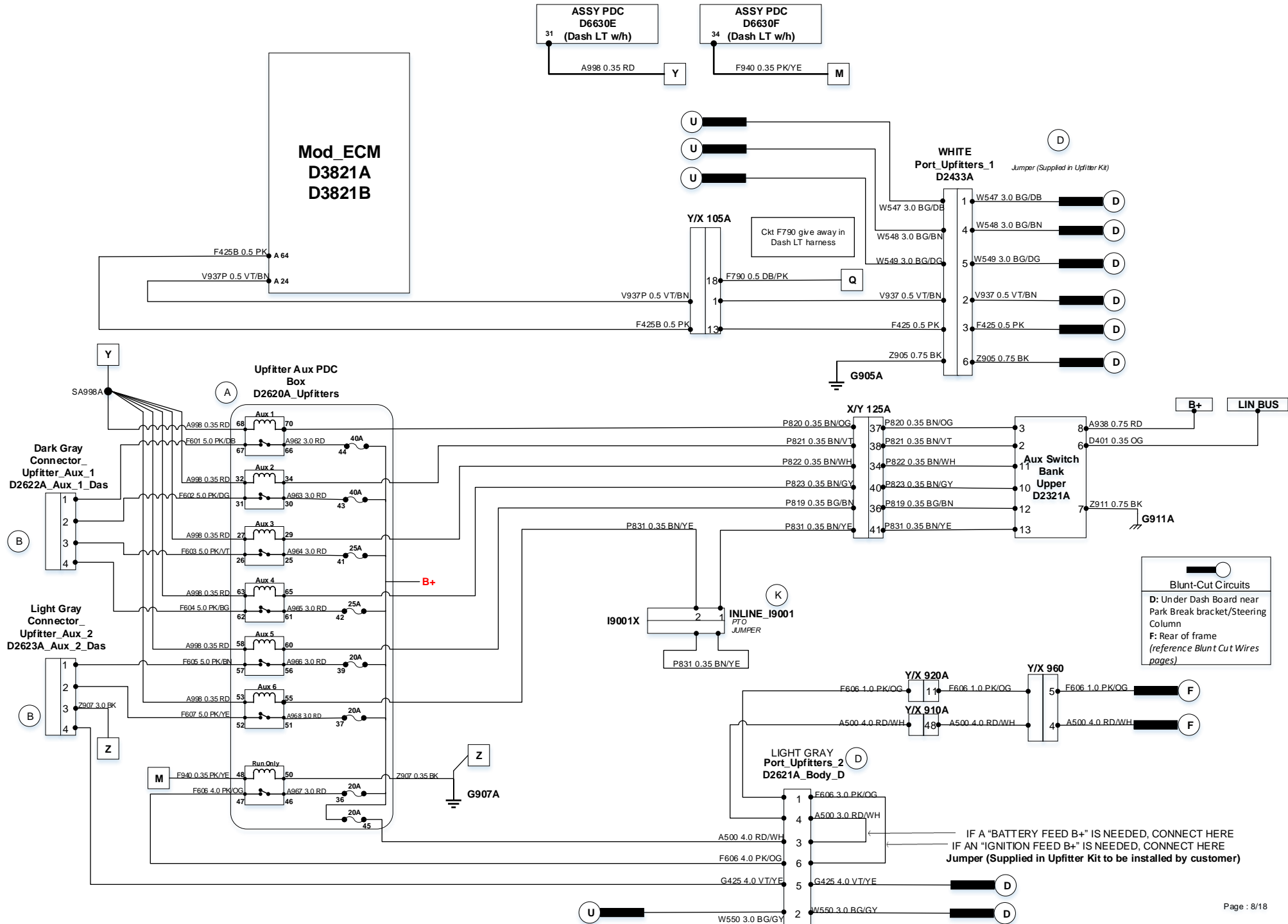

Blunt-Cut Circuits
 D: Under Dash Board near Park Break bracket/Steering Column
 F: Rear of frame (reference Blunt Cut Wires pages)

IF A "BATTERY FEED B+" IS NEEDED, CONNECT HERE
 IF AN "IGNITION FEED B+" IS NEEDED, CONNECT HERE
 Jumper (Supplied in Upfitter Kit to be installed by customer)

2021 UPFITTER SCHEMATIC

2500/3500 PICK UP
With Aux Switches
Sales code (LHL)

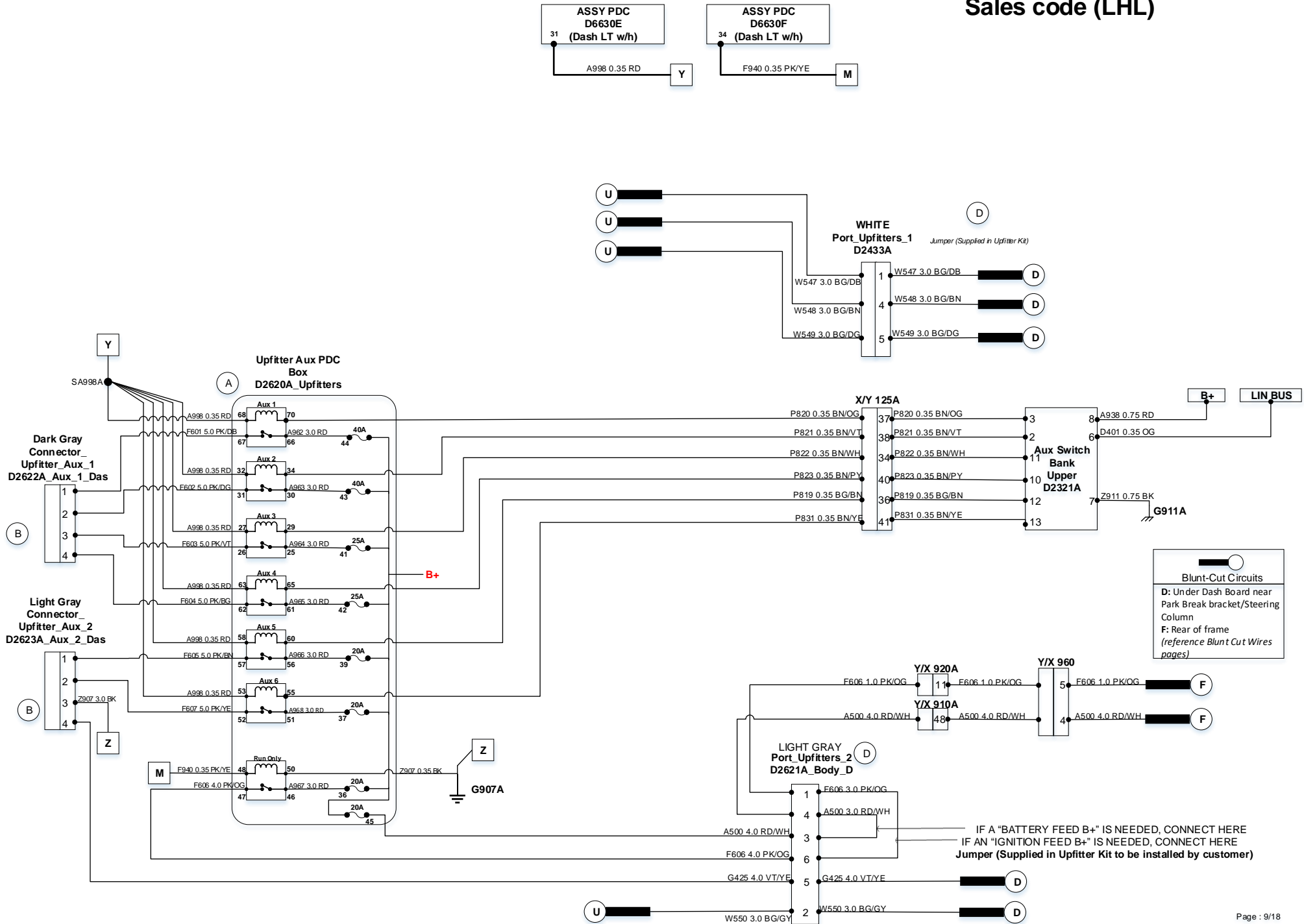

2021 UPFITTER SCHEMATIC

Blunt Cut Wires 3500/4500/5500 CHASSIS CAB

"G" Blunt Cut wires located at Rear of Frame

W750 RD (TRAILER TOW BATT FEED)	G #
W754 DB (TRAILER TOW ELECTRIC BRAKE FEED)	G #
W756 BN (TRAILER TOW PARK LAMPS)	G #
W751 BK (TRAILER TOW BACK-UP LAMPS FEED)	G #
W752 DG (TRAILER TOW TURN/STOP SIG RT)	G #
W753 YE (TRAILER TOW TURN/STOP SIG LT)	G #
W755 WH (Ground)	G #

The maximum allowable amperage for the Trailer Tow lighting circuits will be 14 A continuous.

The maximum allowable amperage for the Trailer Tow battery feed (W750) will be 21 A continuous.

"H" Blunt Wires located underneath PDC **C**

* H	L177 WH/BR (PARK LAMP RELAY CNTRL) LSD
H	L312 BK/VT (SNOW PLOW FRONT LIGHTNING HS ENABLE)
* H	L313 BK/GN (SNOW PLOW LOW BEAM RELAY CTRL LT) LSD
* H	L315 BK/BU (SNOW PLOW HIGH BEAM RELAY CTRL LT) LSD
* H	L317 WH/VT (SNOW PLOW TURN RELAY CTRL LT) HSD
* H	L318 VT/BN (SNOW PLOW TURN RELAY CTRL RT) HSD
H	T754 DG/GY (HARD WIRED REMOTE START SIG)
U	W547 BG/DB (DASH PASS THRU)
U	W548 BG/BN (DASH PASS THRU)
U	W549 BG/DG (DASH PASS THRU)
U	W550 BG/GY (DASH PASS THRU)

* The snowplow lighting outputs are relay drivers only, capable of 0.20 amps each. They are not intended to drive lamps directly. For more information on lighting connections, see the **Snowplow Lighting Interface** document the BBG..

"U" Blunt Wires located Near of Aux PDC **A**

VEHICLE WIRING	
W547 BG/DB (DASH PASS THRU)	D
W548 BG/BN (DASH PASS THRU)	D
W549 BG/DG (DASH PASS THRU)	D
W550 BG/GY (DASH PASS THRU)	D
V937 VT/BN (SPEED CTRL SW RTN)	D
F425 PK (PWR - PTQ SWITCH)	D
Z905 BK (GND - GENERIC 5)	D
G425 VT/YE (PASS THRU)	D

"D" Blunt Cut wires are part of the Upfitter Pots 1 & 2 Jumpers located under Dash near Park Brake Bracket/Body Control Module. Connector (Black & Gray) for these circuits are part of the Upfitter Jumper kit.

**These two circuits become active when the 6 cavity Light Gray connector (Jumper por Upfitter 2) included in the upfitter kit is installed onto the Light Gray connector at location 'D' in the vehicle diagram

** A500 RD/WH (UPFITTER FUSED B+ FEED)	F
** F606 PK/OG (UPFITTER IGN RUN FEED)	F
L56 WT/VT (STOP LAMP SIG/CHMSL FEED)	F

"F" Blunt Cables wires located at Rear of Frame

2021 UPFITTER SCHEMATIC







Blunt Cut Wires 2500/3500 Pickup Box-off (Sales Code XBC)

"M" Blunt Cut wire located at Right (Passenger Side), in the second crossmember from rear to front.

"G" Blunt Cut wires located at Rear of Frame

M  L56 WH/VT (STOP LAMP SIG/CHMSL FEED)

"H" Blunt Wires located underneath PDC (C)





- * H  L177 WH/BR (PARK LAMP RELAY CNTRL) LSD
- H  L312 BK/VT (SNOW PLOW FRONT LIGHTNING HS ENABLE)
- * H  L313 BK/GN (SNOW PLOW LOW BEAM RELAY CTRL LT) LSD
- * H  L315 BK/BU (SNOW PLOW HIGH BEAM RELAY CTRL LT) LSD
- * H  L317 WH/VT (SNOW PLOW TURN RELAY CTRL LT) HSD
- * H  L318 VT/BN (SNOW PLOW TURN RELAY CTRL RT) HSD
- H  T754 DG/GY (NOT USED)

- U  W547 BG/DB (DASH PASS THRU)
- U  W548 BG/BN (DASH PASS THRU)
- U  W549 BG/DG (DASH PASS THRU)
- U  W550 BG/GY (DASH PASS THRU)

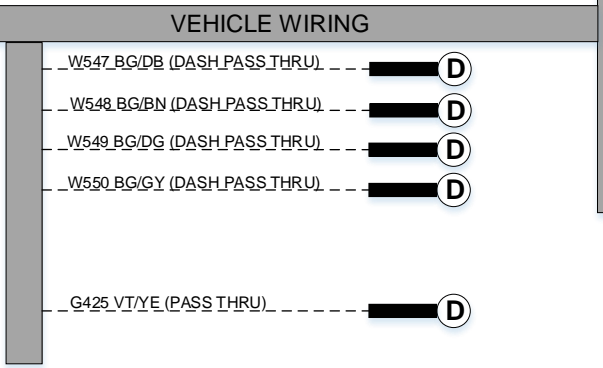
* The snowplow lighting outputs are relay drivers only, capable of 0.20 amps each. They are not intended to drive lamps directly. For more information on lighting connections, see the **Snowplow Lighting Interface** document the BBG..





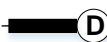

"U" Blunt Wires located Near of Aux PDC (A)

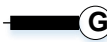
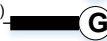

- W547 BG/DB (DASH PASS THRU)  (D)
- W548 BG/BN (DASH PASS THRU)  (D)
- W549 BG/DG (DASH PASS THRU)  (D)
- W550 BG/GY (DASH PASS THRU)  (D)



G425 VT/YE (PASS THRU)  (D)

"D" Blunt Cut wires are part of the Upfitter Ports 1 & 2 Jumpers located under Dash near Park Brake Bracket/Body Control Module. Connector (Black & Gray) for these circuits are part of the Upfitter Jumper kit.

- W750 RD (TRAILER TOW BATT FEED)  (G) #
- W754 DB (TRAILER TOW ELECTRIC BRAKE FEED)  (G) #
- W756 BN (TRAILER TOW PARK LAMPS)  (G) #
- W751 BK (TRAILER TOW BACK-UP LAMPS FEED)  (G) #
- W752 DG (TRAILER TOW TURN/STOP SIG RT)  (G) #
- W753 YE (TRAILER TOW TURN/STOP SIG LT)  (G) #
- W755 WH (Ground)  (G) #

The maximum allowable amperage for the Trailer Tow lighting circuits will be 14 A continuous.
The maximum allowable amperage for the Trailer Tow battery feed (W750) will be 21 A continuous.

**These two circuits become active when the 6 cavity Light Gray connector (Jumper por Upfitter 2) included in the upfitter kit is installed onto the Light Gray connector at location 'D' in the vehicle diagram

- ** A500 RD/WH (UPFITTER FUSED B+ FEED)  (F)
- ** F606 PK/OG (UPFITTER IGN RUN FEED)  (F)

"F" Blunt Cables wires located at Rear of Frame

2021 UPFITTER SCHEMATIC

Blunt Cut Wires 2500/3500 Pickup Box-on W/Auxiliary Switches (Sales Code LHL)

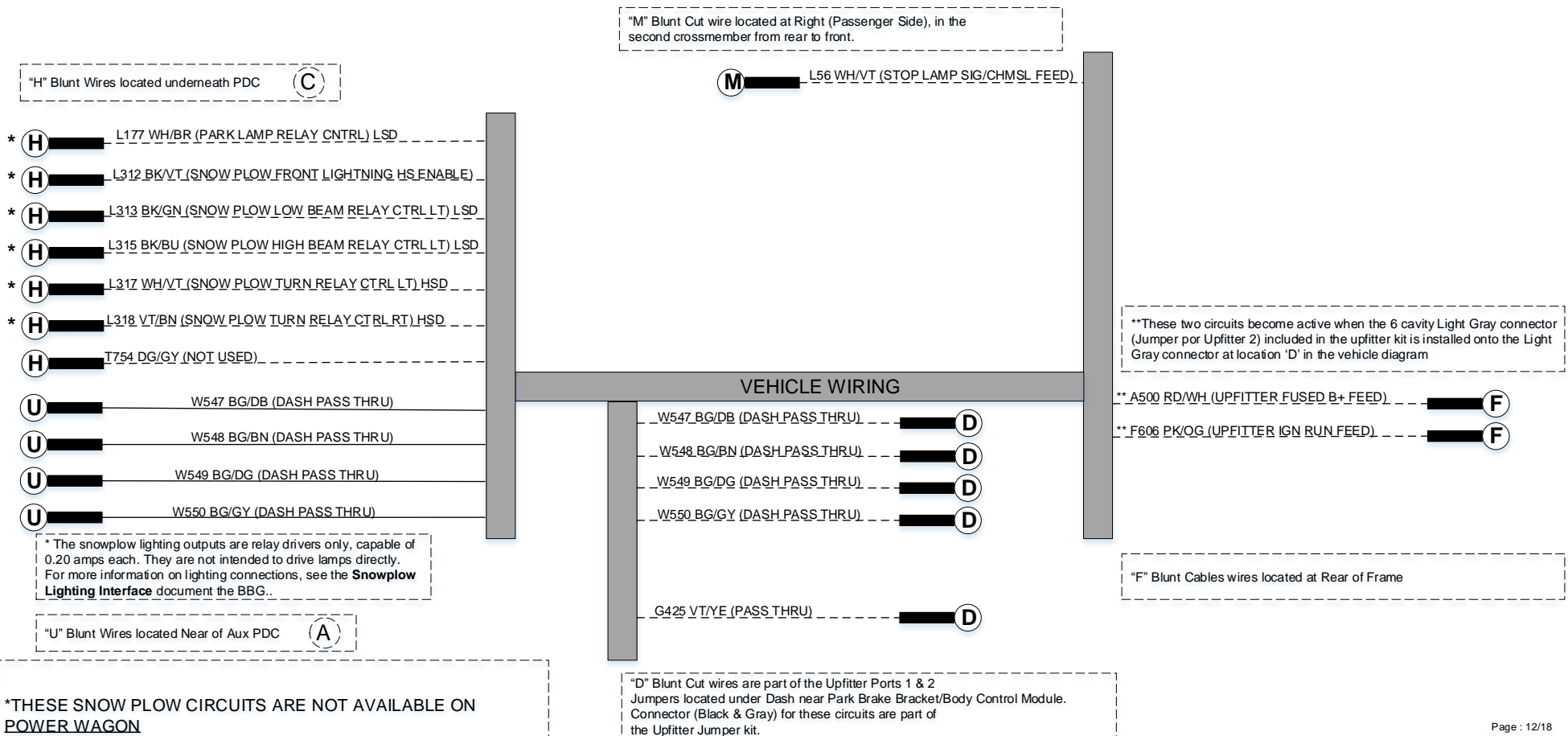

2021 UPFITTER SCHEMATIC

Blunt Cut Wires 2500/3500 Pickup Box-on W/O Auxiliary Switches

"H" Blunt Wires located underneath PDC (C)

- * (H) [REDACTED] L177 WH/BR (PARK LAMP RELAY_CNTRL) LSD
- * (H) [REDACTED] L312 BK/VT (SNOW PLOW FRONT LIGHTNING_HS_ENABLE)
- * (H) [REDACTED] L313 BK/GN (SNOW PLOW LOW BEAM RELAY_CTRL_LT) LSD
- * (H) [REDACTED] L315 BK/BU (SNOW PLOW HIGH BEAM RELAY_CTRL_LT) LSD
- * (H) [REDACTED] L317 WH/VT (SNOW PLOW TURN RELAY_CTRL_LT) HSD
- * (H) [REDACTED] L318 VT/BN (SNOW PLOW TURN RELAY_CTRL_RT) HSD

"M" Blunt Cut wire located at Right (Passenger Side), in the second crossmember from rear to front.

(M) [REDACTED] L56 WH/VT (STOP LAMP_SIG/CHMSL_FEED)

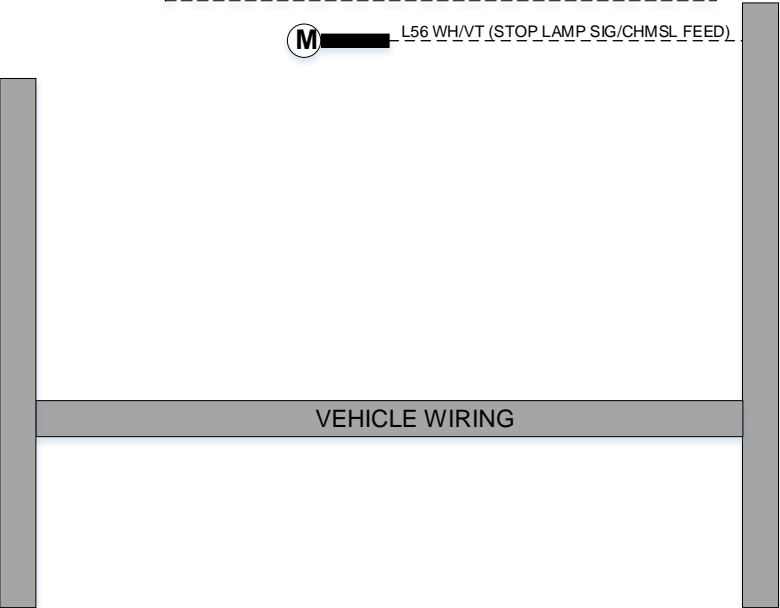

* The snowplow lighting outputs are relay drivers only, capable of 0.20 amps each. They are not intended to drive lamps directly. For more information on lighting connections, see the **Snowplow Lighting Interface** document the BBG..

*THESE SNOW PLOW CIRCUITS ARE NOT AVAILABLE ON POWER WAGON

The maximum allowable continuous amperage for these Snow Plow circuits will be found under "ELECTRICAL/WIRING INFORMATION", "ELECTRICAL POWER USAGE", "AMPERAGE CAPACITY PER CIRCUIT".

2021 UPFITTER SCHEMATIC

Upfitter Jumper Harness Only

PTO Connector
(Wire Insertion End of Up Fitter Cap)

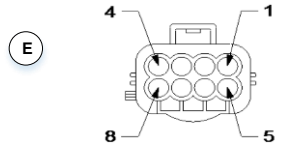

- 1 K400 0.35 BN/VT (ENF – ACCEL PEDAL POS SNSR RTN 2)
- 2 F856 0.5 YE/PK (ENG – 5V ENGINE SNSR FEED SEC)
- 3 K128 0.5 DB/GN (ENG – REMOTE THROTTLE SWITCH SIGNAL)
- 4 K129 0.5 DB/DG (ENG – REMOTE THROTTLE SWITCH)
- 5 K119 0.5 GN/BK (ENG – MAXIMUM OPERATING SPEED SWITCH)
- 6 K810 0.5 VT/DG (ENG – ACCELERATOR INTERLOCK SWITCH)
- 7 F425 0.5 PK (PWR – POWER TAKEOFF SWITCH)
- 8 V937 0.35 VT/BN (SCS – SPEED CTRL SW RTN)

Dash_Dark Gray
Connector_Upfitter Aux_1
(Wire Insertion End of Up Fitter Cap)

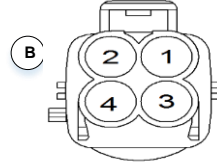

- 1 F601 3.0 PK/DB (RELAY 1 OUTPUT)
- 2 F602 3.0 PK/DG (RELAY 2 OUTPUT)
- 3 F603 3.0 PK/VT (RELAY 3 OUTPUT)
- 4 F604 3.0 PK/BG (RELAY 4 OUTPUT)

*Note – Each Circuit can handle maximum continuous current of 28A. Maximum combined load for AUX Switches is 133A
*The upfitter/customer is responsible for placing the correct fuse in the correct location depending on the actual load.

Dash_Light Gray
Connector_Upfitter_2 Aux_2
(Wire Insertion End of Up Fitter Cap)

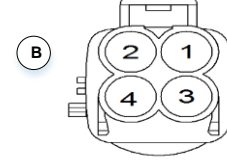

- 1 F605 3.0 PK/BN (RELAY 5 OUTPUT)
- 2 F607 3.0 PK/YE (RELAY 6 OR PTO RELAY OUTPUT)
- 3 Z907 3.0 BK (GND)
- 4 G425 3.0 VT/YE (Pass Thru)

Jumper
Port_Upfitters_1
(Wire Insertion End of Up Fitter Cap)

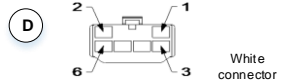

- 1 W547 3.0 BG/DB (Dash Pass Thru)
- 2 V937 0.35 VT/BN (PTO/SEIU SW RTN)
- 3 F425 0.5 PK PTO/SEIU SWITCH)
- 4 W548 3.0 BG/BN (Dash Pass Thru)
- 5 W549 3.0 BG/DG (Dash Pass Thru)
- 6 Z905 0.75 BK (GROUND)

Jumper
Port_Upfitters_2
(Wire Insertion End of Up Fitter Cap)



- 1 F606 3.0 PK/OR (PWR – ATM UPFITTER IGN RUN FEED)
- 2 W550 3.0 BG/GY (Dash Pass Thru)
- 3 A500 3.0 RD/WH (PWR – BATT – ATM – UPFITTER FUSED FEED)
- 4 G425 4.0 12T VT/YL (Pass Thru)

THESE ARE NORMALLY NOT CUSTOMER REPLACED

Jumper
PTO
(Wire Insertion End of Up Fitter Cap)

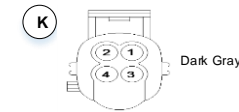

- 1 K425 0.35 OG/BN
- 2 K427 0.5 OG/GN

Jumper
NON-PTO
(Aux 6) (Wire Insertion End of Up Fitter Cap)

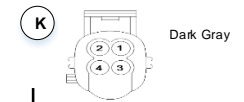

- 1 P831 0.35 BN/YE

2021 UPFITTER SCHEMATIC

PTO CONNECTOR Under the Vehicle at Transmission Circuit Function and Pin – Out 3500/4500/5500 CHASSIS CAB ONLY

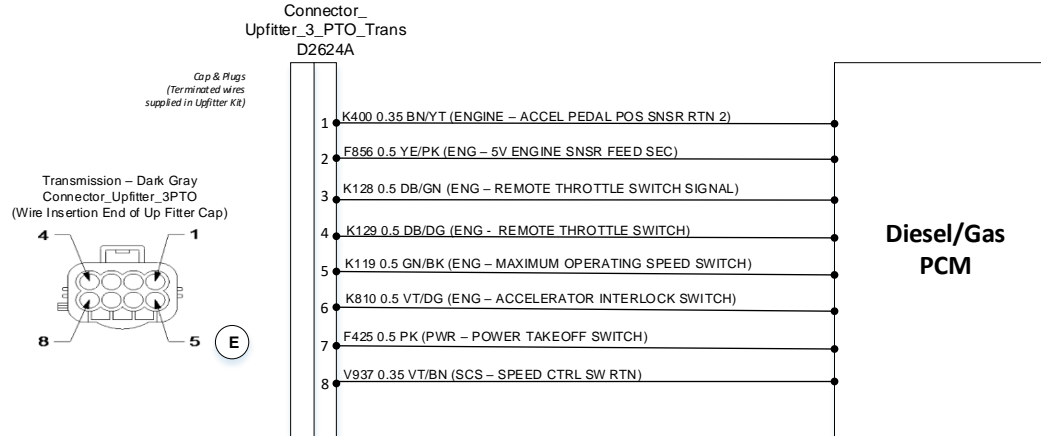

2021 UPFITTER SCHEMATIC

Bagged Upfitter Kit Detail 68512072

- (8) Circuits for Up fitter Aux Connectors 1 & 2 – 5.0 mm (6), 4.0 mm (1), 3.0 mm (1)
- (8) Circuits for the Connector_Upfitter_3_PTO_Trans Connector – All 0.5 mm
- (2) PTO/Non-PTO Jumper Connectors
- (1) Port_Upfitter_2 – Gray Connector w/6 wires
- (1) Port_Upfitter_1 – Black Connector w/6 wires

The Vehicle has been equipped to ease the installation of a PTO by allowing convenient access to circuits needed without having to splice into the main harness.

Located left of Main PDC Box and along the left (Drivers Side) fender inner (location K) is a dark gray jumper connector that allows the vehicle function to switch between PTO and non-PTO operation, although this normally need not be accessed by the customer. If required, the jumpers are located in this upfitter kit. If necessary, verify proper jumper usage by reviewing jumper design on previous pages.

In the rear of chassis cabs and Pickups, you can find all required Trailer -Tow circuits, two (2) additional power circuits (1 Battery and 1 Ignition) and a Stop Lamp / CHMSL Feed Circuit.

In the Engine compartment you will find two (2) (A Light Gray and a Dark Gray) Upfitter AUX connectors (location B) which allow easy access to the switch bank and fuse box outputs, mating terminated circuits are included in this kit as needed. Connectors (Black & Gray) for these circuits are part of the upfitter jumper kit.

Warning about adding auxiliary batteries:

An auxiliary battery may be used, however a battery isolation unit is not supplied and the auxiliary battery may discharge the truck battery when the engine is not running.

Ground Studs on the chassis/frame may be utilized as a grounding point with a 50A Maximum total load, see “Vehicle Ground Locations” section in the RAM Body Builder Guide, Electrical/Wiring Information.

WIRE SIZE REFERENCE

WIRE GAUGE US (AWG)	WIRE GAUGE METRIC Only Copper (mm)	WIRE GAUGE Copper + Insulation (mm)
22	0.35	1.3
20	0.5	1.6
19	0.75	1.9
18	0.8	2
16	1	2.1
15	1.5	2.4
14	2	2.6
13	2.5	3
12	3	3.3
	4	3.7
10	5	4.2
	6	4.3
8	8	5.5
	10	6
6	13	
	15	7
	16	7.9
4	19	
3	25	9.4
	30	11
2	32	
	35	11.6
1	40	12.4
1/0	50	13.5
2/0	62	
3/0	70	15.5

Wire Color Abbreviations

Table 1 - Wire Color Abbreviations

RED	RD
BLACK	BK
BROWN	BN
ORANGE	OG
VIOLET	VT
WHITE	WH
GRAY	GY
YELLOW	YE
DK BLUE	DB
DK GREEN	DG
LT GREEN	GN
LT BLUE	BU
TAN	BG
PINK	PK