

Views & Charts 2019 3500 Chassis Cab  
 Reg Cab, 60CA, DRW

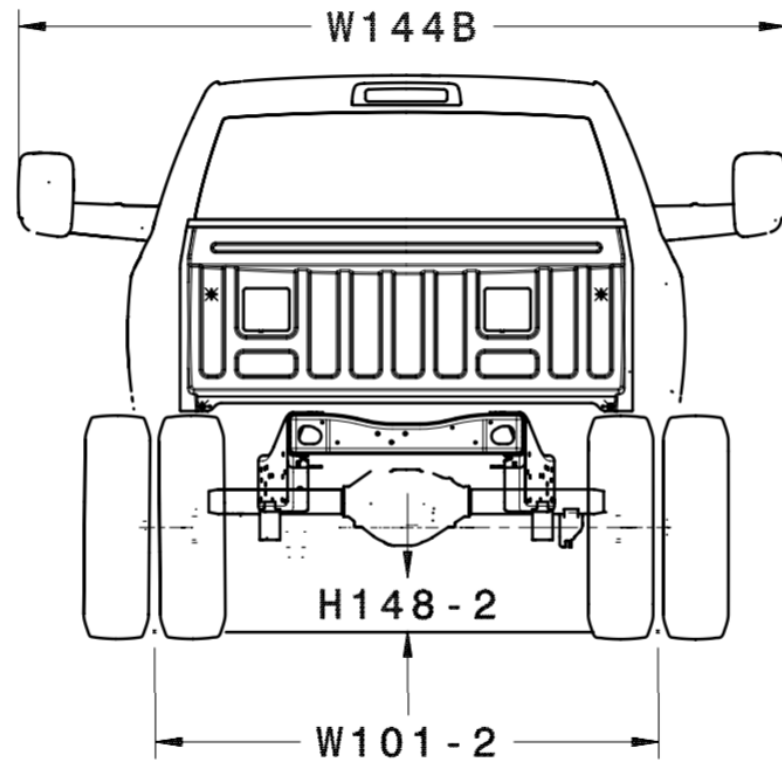
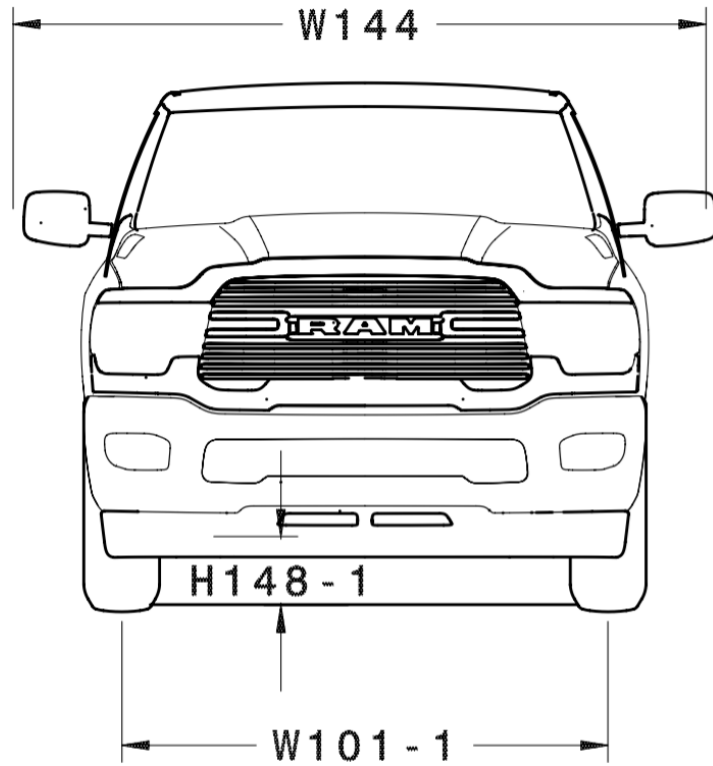

**Views & Charts 2019 3500 Chassis Cab  
Reg Cab, 60CA, DRW**

Code	Description	235/80R17	
		Metric	English
A106-1	Angle of Approach	20.4 deg	20.4 deg
A106-2	Angle of Departure	26.9 deg	26.9 deg
A147	Ramp Breakover Angle	20.7 deg	20.7 deg
CG_H511	Bottom of Open Hood to Ground	2187.4 mm	86.1 in
CG_TRH7	Top of Frame(at rear) to Ground	911.0 mm	35.9 in
CG_TT18	Turn Circle Diameter (feet/meters)*	14.1 m	46.3 ft
H5-1	SgRP to Ground - Front	1057.0 mm	41.6 in
H101	Vehicle Height(curbsLoad)	2036.0 mm	80.2 in
H103-1	Fascia(Bumper) to Ground - Front	251.2 mm	9.9 in
H108-1	Static Load Radius - Front Tire *	379.4 mm	14.9 in
H108-2	Static Load Radius - Rear Tire *	392.3 mm	15.4 in
H130-1	Step Height - Front	697.0 mm	27.4 in
H148-1	Suspension or Axle to Ground - Front	219.0 mm	8.6 in
H148-2	Suspension or Axle to Ground - Rear	203.0 mm	8.0 in
L101	Wheelbase	3645.0 mm	143.5 in
L104	Overhang - Front	1031.9 mm	40.6 in
L105	Overhang - Rear	1300.0 mm	51.2 in
L114	Front Wheel Centerline toSgRP - Front	1471.4 mm	57.9 in
L404	Cab to Rear Axle (CA)	1524.3 mm	60.0 in
W101-1	Tread Width - Front Tires	1768.0 mm	69.6 in
W101-2	Tread Width - Rear Tires	1825.0 mm	71.9 in

Views & Charts 2019 3500 Chassis Cab  
Reg Cab, 60CA, DRW

Code	Description	LENGTH	
		Metric	English
CG_TRL4	Back of Cab to Taillamp	2846.8 mm	112.1 in
L103	Vehicle Length	5977.0 mm	235.3 in
L403	Front Bumper to Back of Cab (BBC)	3153.0 mm	124.1 in
L410	Cab Length	1839.5 mm	72.4 in

Code	Description	HEIGHT	
		Metric	English
A18	Steering Wheel Angle	22.9 deg	22.9 deg
A130-1	Glazing Angle - Windscreen	56.4 deg	56.4 deg
CG_A18	Steering Column Angle	23.4 deg	23.4 deg
CG_TRH4	Top of Frame to top of Cab	1218.9 mm	48.0 in
H6	SgRP - Front to Windshield Lower DLO	458.2 mm	18.0 in
H61-1	Effective Head Room - Front	1011.0 mm	39.8 in

Code	Description	WIDTH	
		Metric	English
CG_FW3	Rear Suspension Front Spring Bolt	1196.2 mm	47.1 in
CG_FW4	Rear Suspension Rear Spring Bolt	1243.2 mm	49.0 in
CG_FW5	Rear Frame - Inside Width	711.2 mm	28.0 in
CG_FW6	Rear Frame - Outside Width	859.6 mm	33.8 in
CG_TRW6	Outside of Rear Tires	2334.0 mm	91.9 in
W144	Vehicle Width-Mirrors Included (Std)	2464.4 mm	97.0 in
W144B	Vehicle Width-Mirrors Included (Trailer)	2776.1 mm	109.3 in
W106	Fender Width - Front	2010.2 mm	79.1 in
W117	Body Width At SgRP - Front	2005.2 mm	78.9 in
W120-1	Vehicle Width, Doors Open - Front	4513.7 mm	177.7 in

Views & Charts 2019 3500 Chassis Cab  
Reg Cab, 60CA, DRW